

# RADIO-CRAFT

HUGO GERNSBACK, *Editor*

**WAR**  
and **RADIO**  
See Page 328

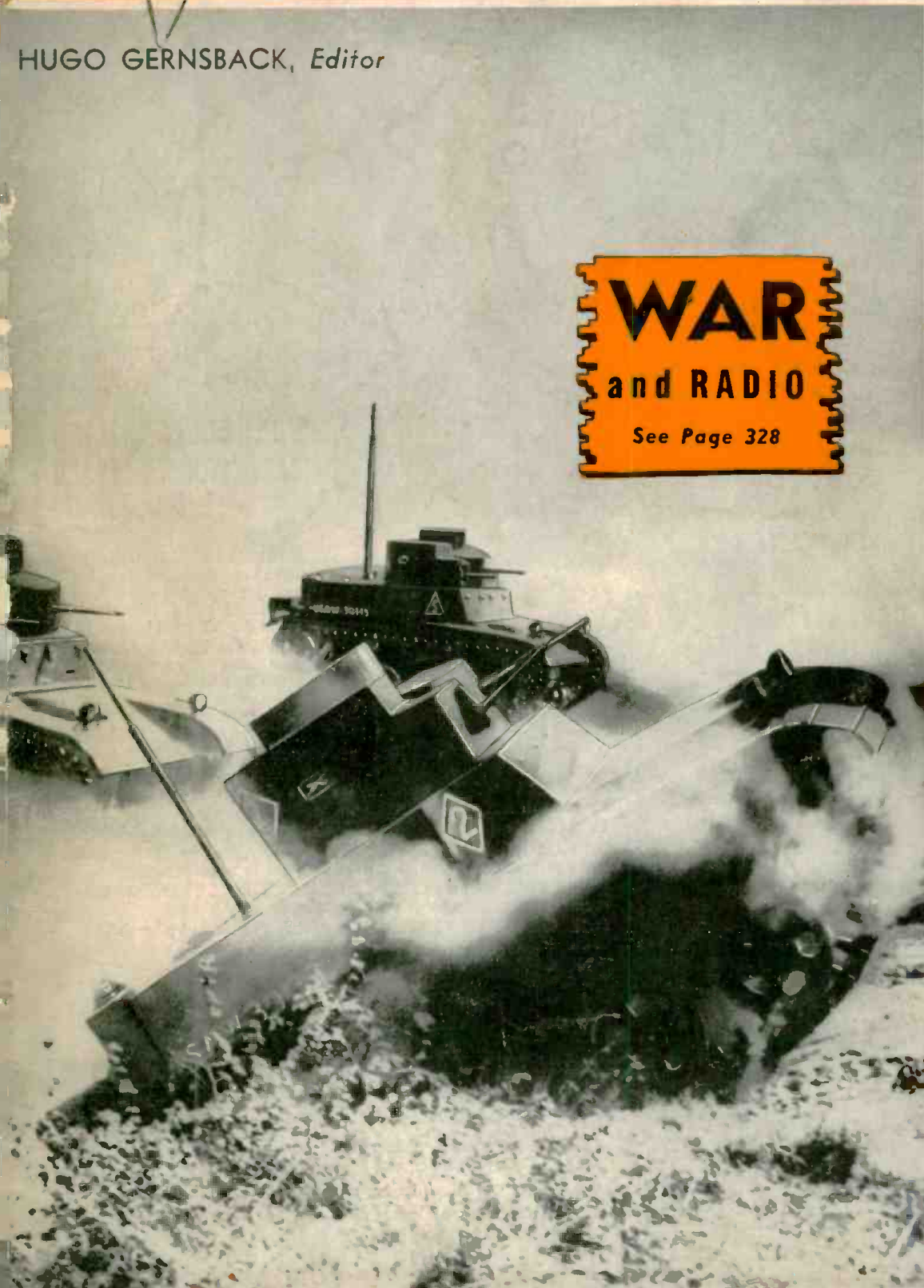

**TELLY OSCILLOSCOPE**

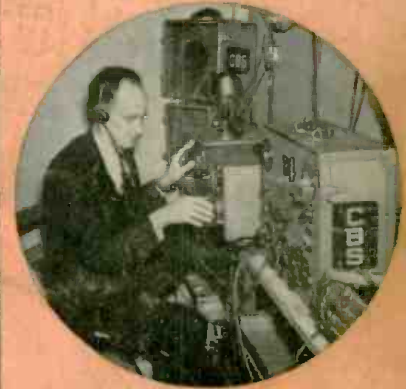

**WAR NEWS PICK-UP**

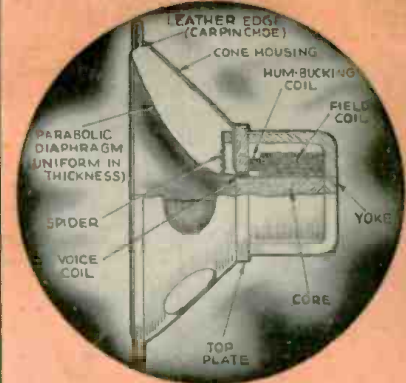

**SUPER HI-FI SPEAKER**



**HEARS ELECTRIC CHARGES**

DEC. RADIO'S GREATEST MAGAZINE

25c  
CONDUCTANCE OR EMISSION TEST? • CONTEST AWARDS—4TH GROUP  
HI-FI SET HAS "HARMONIC CONVERSION" • WAR NEWS BY RADIO

IN U. S. AND CANADA



# Servicemen!

## SAVE TIME • BE SURE!

with these precision instruments  
 experience-built by Cornell-Dubilier

Cornell-Dubilier offers two great capacitor test instruments to help you build a better business. The most envied experience in capacitors is at your service at no extra cost in C-D's new Capacitor Analyzer and its compact running mate, the Capacitor Bridge. For quick, accurate capacitor measurements, take advantage of these mighty values — reduce servicing time . . . increase profit and prestige. Read the feature story —



FOR  
 SERVICEMEN  
 AND TECHNICIANS

### CORNELL-DUBILIER CAPACITOR BRIDGE

MODEL BN



Measures Capacity . . . . of all type capacitors between limits of .00001 mfd. and 50 mfd.

Detects Defective Capacitors . . . . will check for opens, shorts, high and low capacity, and high power-factor.

Checks Circuit Continuity . . . . may be used as continuity meter.

Employs Wien Bridge . . . . accuracy independent of line voltage variations.

Visual Eye Bridge Balance . . . . dual type visual bridge balance for accurate measurements facilitates quick tests on service jobs.

Direct Reading Scale . . . . direct reading ranges with all scale markings directly in microfarads.

Dealer's Net . . . . . \$9.90



FOR LABORATORY  
 AND SHOP!

### CORNELL-DUBILIER CAPACITOR ANALYZER

MODEL BF-50

MEASURES CAPACITY. Measures capacity of paper, mica, air, electrolytic and motor starting capacitors from .00001 to 240 mfd.

MEASURES POWER FACTOR. Measures power factor from 0 to 50% on all types of electrolytics including motor starting types.

INDICATES INSULATION RESISTANCE. Measures insulation resistance of paper and mica capacitors.

INDICATES LEAKAGE. Measures leakage of electrolytics by means of built-in D.C. power supply.

LEAKAGE INDICATOR. Leakage tests on all capacitors.

HIGH SENSITIVITY. Amplifier for capacity, power factor and leakage tests provides sharp and accurate readings.

DIRECT READING LINEAR SCALE CALIBRATIONS. All scales uniformly spaced. Six color coded scales.

PUSH BUTTON SWITCHING. All test changes made by push button switches.

SELF CONTAINED . . . PORTABLE. Complete, portable, for 110 V. 50-60 cycle operation. Walnut cabinet with removable cover and carrying handle.

Low Dealer Net Price (less tubes) . . . . . \$24.90

CORNELL-DUBILIER ELECTRIC CORPORATION,  
 SOUTH PLAINFIELD, NEW JERSEY

Please rush to me the following catalog material.

- Catalog No. 167A on Capacitor Instruments.
- Catalog No. 175A on capacitors.
- Catalog No. 166A on Quietone Interference Filters.
- Place me on your mailing list for Free C-D House Organ.

RC1239

Name . . . . .  
 Address . . . . .  
 City . . . . . State . . . . .

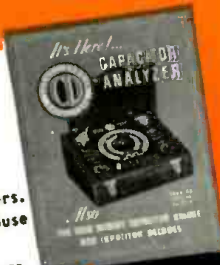

### A NEW CATALOG

1939-40 edition, tells all about these precision instruments. Get the facts and, in capacitor equipment — as in capacitors, you, too, will go Cornell-Dubilier. Tear off and mail the coupon for your copy of Catalog No. 167-A.



# CORNELL-DUBILIER ELECTRIC CORPORATION

1014 Hamilton Boulevard, South Plainfield, New Jersey

Cable Address: "CORDU"





# Be a RADIO Technician

**Many make \$30 \$40 \$50 a week**

**I will train you at home for many Good Spare Time and Full Time Radio Jobs**

**J. E. SMITH, President, National Radio Institute**  
Established 25 years  
He has directed the training of more men for the Radio Industry than anyone else.



**Set Servicing** pays many Radio Technicians \$30, \$40, \$50 a week. Others hold their regular jobs and make \$5 to \$10 extra a week in spare time.

**Broadcasting Stations** employ operators, installation, maintenance men and Radio Technicians in other capacities and pay well.



**Loud Speaker System** building, installing, servicing and operating is another growing field for well trained Radio Technicians.

## I Trained These Men



**\$10 to \$20 Week in Spare Time**

"I repaired many Radio sets when I was on my tenth lesson. I made \$600 in a year and half, and I have made an average of \$10 to \$20 a week—just spare time."  
**JOHN JERBY, 1529 Arapahoe St., Denver, Colo.**

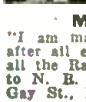

**Makes \$50 to \$60 a Week**

"I am making between \$50 and \$60 a week after all expenses are paid, and I am getting all the Radio work I can take care of, thanks to N. B. I." **H. W. SPANGLER, 126 1/2 S. Gay St., Knoxville, Tenn.**



**Operates Public Address System**

"I have a position with the Los Angeles Civil Service, operating the Public Address System in the City Hall Council. My salary is \$170 a month." **R. H. HOOD, R. 136, City Hall, Los Angeles, Calif.**



## Sample Lesson Free

I want to prove our Course gives practical, money-making information, that it is easy to understand—what you need to master Radio. My sample lesson text, "Radio Receiver Troubles—Their Cause and Remedy," covers a long list of Radio receiver troubles in A.C., D.C., battery, universal, auto, T.R.F., super-heterodyne, all-wave, and other types of sets. And a cross reference system gives you the probable cause and a quick way to locate and remedy these set troubles. A special section is devoted to receiver check-up, alignment, balancing, neutralizing, testing. Get this lesson Free by mailing the coupon.

Radio is a young, growing field with a future. It offers you many good pay spare time and full time job opportunities. And you don't have to give up your present job, go away from home, or spend a lot of money to become a Radio Technician. I train you right at home in your spare time.

**Jobs Like These Go to Men Who Know Radio**

Radio broadcasting stations employ engineers, operators, technicians and pay well for trained men. Radio manufacturers employ testers, inspectors, foremen, servicemen in good-pay jobs with opportunities for advancement. Radio jobbers and dealers employ installation and servicemen. Many Radio Technicians open their own Radio sales and repair businesses and make \$30, \$40, \$50 a week. Others hold their regular jobs and make \$5 to \$10 a week fixing Radios in spare time. Automobile, police, aviation, commercial Radio: loudspeaker systems, electronic devices, are newer fields offering good opportunities to qualified men. And my Course includes Television, which promises to open many good jobs soon.

**Why Many Radio Technicians Make \$30, \$40, \$50 a Week**

Radio is already one of the country's large industries even though it is still young and growing. The arrival of Television, the use of Radio principles in industry, are but a few of many recent Radio developments. More than 28,000,000 homes have one or more Radios. There are more Radios than telephones. Every year millions of Radios get out of date and are replaced. Millions more need new tubes, repairs, etc. Over 5,000,000 auto Radios are in use and thousands more are being sold every day. In every branch Radio is offering more opportunities—opportunities for which I give you the required knowledge of Radio at home in your spare time. Yes, the few hundred \$30, \$40, \$50 a week jobs of 20 years ago have grown to thousands.

**Many Make \$5 to \$10 a Week Extra in Spare Time While Learning**

The day you enroll, in addition to my regular Course, I start sending you Extra Money Job Sheets which start showing you how to do actual Radio repair jobs. Throughout your course I send plans and directions which have helped many make \$200 to \$500 a year in spare time while learning. I send special Radio equipment; show you how to conduct experiments, build circuits.

This 50-50 training method makes learning at home interesting, fascinating, practical.

**I Also Give You This Professional Servicing Instrument**



Here is the type of instrument Radio Technicians use—an All-Wave Set Servicing Instrument. It contains everything necessary to measure A.C. and D.C. voltages and current; to check resistances; adjust and align any set, old or new. It satisfies your needs for professional servicing after you graduate—can help you make extra money fixing sets while learning.

**You Are Trained for Television Also**

With N.R.I. you learn Television principles right along with Radio principles—the correct method—since Television receivers combine both sight and sound. You also get more than ten text books devoted entirely to Television.

**Get Sample Lesson and 64-Page Book Free—Mail Coupon**

Act today. Mail coupon now for Sample Lesson and 64-page Book. They're FREE. They point out Radio's spare time and full time opportunities and those coming in Television; tell about my course in Radio and Television; show many letters from men I trained, telling what they are doing and earning. Read my money back agreement. Find out what Radio offers you. Mail coupon in envelope or paste on penny postcard—NOW.

**J. E. SMITH, President, Dept. 9NX, National Radio Institute Washington, D. C.**



## Good for Both 64 PAGE BOOK Free

**J. E. SMITH, President, National Radio Institute Dept. 9NX, Washington, D. C.**

Without obligating me, send your Sample Lesson and 64-page Book FREE. I am particularly interested in the branch of Radio checked below.

- Radio Service Business of My Own
- Service Technician for Retail Stores
- Spare Time Radio Repair Work
- Broadcasting Station Operator
- Aviation Radio Technician (If you have not decided which branch you prefer—mail coupon now, for information to help you decide.)
- Loud Speaker Systems, Installations and Service
- Auto Radio Installations and Service
- Television Station Operator
- Commercial Radio Station Operator
- All-around Servicing Technician

Name ..... Age .....

Address ..... 14X1

Please Say That You Saw It in RADIO-CRAFT

# RADIO-CRAFT

HUGO GERNSBACK, *Editor-in-Chief*

N. H. LESSEM  
*Associate Editor*

THOS. D. PENTZ  
*Art Director*

ROBERT EICHBERG  
*Trade Digest Editor*

R. D. WASHBURNE, *Managing Editor*

## Contents DECEMBER, 1939 Issue

VOLUME XI -- NUMBER 6

Editorial: "Static-less" Radio.....	Hugo Gernsback	325
The Radio Month in Review.....		326
Radio Aids U. S. War Machine.....		328
War News Via Radio.....		329
Newest Hi-Fi 9-Tube Superhet. Introduces "Harmonic Conversion" .....	P. Wilson Redcay	330
4th Group of Prize Winners— <i>Radio-Craft's</i> P.A. Contest.....		333
New Condenser Analyzer—Thrifty Service Tool.....	Leon L. Adelman	334
Emission vs. Mutual Conductance Test.....	E. T. Higgons	335
Frequency-Modulated Programs on Your Present Receiver!—With This Easily-Built F.M.-A.M. Ultra-S.W. Adapter—Part I—Frequency vs. Amplitude Modulation.....	Glenn H. Browning and F. J. Gaffney	336
New Circuits in Modern Radio Receivers—No. 27....	F. L. Sprayberry	338
Wide-Range Loudspeaker—Designed for Reproducing Frequency- Modulated Programs.....	W. S. Bachman	339
New "Super-Pro" for DX-ers.....		340
Newest Tube Checker.....		341
How to Add 1 to 14 Modern Features to the All-Push-Pull Direct- Coupled 30-Watt Amplifier—Part III.....	A. C. Shaney	342
For Beginners—A Pentode Pocket Set.....	M. N. Beitman	344
Local Service Shop Capitalizes on Electronic Orchestra..	S. Leibowitz	345
<b>RADIO SERVICE DATA SHEETS:</b>		
No. 266—Stromberg-Carlson Series 410 and 411; Models 410-H, -HB, -J, -JB, -T and -TB; and, 411-PF, -PFB, -PT and -PTB		346
No. 267—RCA Victor Model K-80; Chassis No. RC-415-A.....		347
Novel P.A. Installation Wins 1st Prize in Contest....	Hobart W. Troop	348
More On Staticless Radio Broadcasting.....		350
Operating Notes .....		352
Radio Trade Digest.....		353
The Latest Radio Equipment.....		358
New Ratings for Xmitter Tubes.....		369
Book Reviews .....		323



★

The importance of the "wideband" or Armstrong system of frequency modulation which enables high-fidelity programs to be received without interference is now recognized by the foremost organizations. The General Electric Company, Bell Telephone Laboratories and RCA are investigating its possibilities. Servicemen and other radio technicians, who want to know what "F.M." is all about as compared to "A.M." or amplitude modulation employed by all previously existing radio stations, should read Messrs. Browning's and Gaffney's elementary description in this issue of *Radio-Craft*; the article includes technical information supplied by Major Armstrong, and general data, on new F.M. stations, supplied by Mr. Paul A. deMars of the Yankee Network.

Part II scheduled for next month will describe the construction of a simple unit which permits frequency-modulated programs to be received on any radio broadcast receiver!

★

Published by Radcraft Publications, Inc. Publication office: 29 Worthington Street, Springfield, Mass. Editorial and Advertising Offices: 99 Hudson Street, New York City. Chicago Advertising Office: RADIO-CRAFT, 520 North Michigan Avenue, Chicago, Ill.

RADIO-CRAFT is published monthly, on the first of the month preceding that of date; subscription price is \$2.00 per year in U. S. and Canada. (In foreign countries, \$2.50 a year to cover additional postage.) Entered at the post office at Springfield as second-class matter under the act of March 3, 1879.

Foreign Agents:

- London—Gorrings's American News Agency, 9A Green St., Leicester Square, W. C. 2, England.
- Paris—Messageries Dawson, 4 Rue Faubourg, Poissonniere, France.
- Melbourne—McGill's Agency, 179 Elizabeth St., Australia.
- Dunedin—James Johnston, Ltd., New Zealand.

★

Text and illustrations of this magazine are copyright and must not be reproduced without permission of the copyright owners.

★

Copyright 1939 Radcraft Publications, Inc.



## BOOK REVIEWS

**BIG BUSINESS AND RADIO**, by Gleason L. Archer (1939). Published by The American Historical Company, Inc. Size 6½ x 9½ ins., cloth cover, illustrated, 503 pages. Price, \$4.00.

"Big Business and Radio" brings the history of radio down to the present. Dr. Alfred N. Goldsmith, consulting engineer, describes this book as "the history of 3 simultaneous struggles on the technological, legal and commercial fronts."

From several distinct and outstanding sources the author of "Big Business and Radio" has assembled the story of one of the greatest epochs in the industrial history of the world. To him it has been a thrilling adventure into the unknown—discovering for the first time the day-by-day developments in a contest for supremacy in a great industry. The author has realized very keenly the great opportunity that has been accorded him of being the first historian to look upon these records. He has realized, moreover, his responsibility to future generations that no important detail be overlooked—that no incident be colored by partisanship or bias of any sort (to quote the Preface).

"Historical Background of Television" is the title of Chapter 22 and is a chapter which the average technical man will find of exceptional interest. Its sections are entitled: Experiments with the Selenium Cell, Futile Attempts at Television, Experiments with Mechanical Scanning, Invention of the Iconoscope, RCA and Electronic Television, Field Experiments by RCA, and RCA Launches Television Broadcasting.

It is difficult to convey in the limited space here available a true picture of the importance and scope, and the tremendous amount of research which author Archer, president of Suffolk University, has put into "Big Business and Radio." We can only say that the sources of material include the authentic files of RCA, G.E., N.B.C., C.B.S., M.B.S., the F.C.C., the N.A.B., Zenith Radio Corp., and the cooperation of important executives in these companies, including David Sarnoff, president of the Radio Corporation of America, and of consultants Alfred N. Goldsmith and Frank A. Arnold.

**MODERN MAGNETISM**, by L. F. Bates (1939). Published by Cambridge University Press, The Macmillan Company. Size 6 x 9 ins., cloth cover, 97 illustrations, 340 pages. Price, \$4.50.

In "Modern Magnetism" Professor Bates gives prominence to the description of fundamental experiments; and his particular endeavor has been to give an account of modern magnetic theory that can be followed not only by students of physics, but by more general readers. Accounts of experimental work, particularly foreign work, are included, not only for their contribution to magnetic theory, but for their importance in industrial applications.

Radio-Craft wishes particularly to call to the attention of radio men, Chapter X, "Magnetostriiction," which is rapidly assuming such an important status as a possible substitute for the quartz crystal at the ultra-high-frequencies at which crystals become too thin to operate at fundamental frequencies.

**RADIO DIRECTORY**, Volume III, 1939-1940. Compiled and published by Variety. Size 6½ x 9½ ins., cloth cover, 1352 pages. Price, \$5.00.

Once a year the radio division of Variety (magazine of the entertainment industry) issues a directory of activities throughout the year in the broadcast field. Just issued, the 1939-'40 Variety "Radio Directory," a veritable mine of information, is essential to broadcasting interests and is also useful to technicians who may have need for an authentic reference on such subjects as Federal Radio Regulation; licensed television stations and their characteristics, location, ownership, etc.; and other technical items included in this book.

This year the major emphasis is on the work of the Cooperative Analysis of Broadcasting. This section is the first in the book, and has been painstakingly assembled both as to facts and as to the charts which illustrate it. Ten years of program analysis, and the results of 2,500,000 calls are concisely and clearly incorporated in 80 pages of text and 40 pages of charts, most of them in color.

The information presented on the individual radio stations includes not only all their major departments and activities, but also a list of their news periods—a most timely feature in view of the current war crisis.

# BOOST YOUR INCOME!



**These 3 Big Electrical Guides can help you EARN MORE MONEY**

## EXAMINE 10 DAYS FREE

● No argument about it — the BIG-MONEY JOBS go to those who KNOW HOW! Nowadays you can't expect to hold a good job — you can't expect to get ahead — unless you KNOW YOUR STUFF! But for the fellow who's PREPARED, good jobs, good pay, steady advancement are ahead as always! Why not prepare YOURSELF for the boundless opportunities in ELECTRICITY? These big ELECTRICAL REFERENCE AND INSTRUCTION BOOKS will help you. Equip yourself now for success in this big, modern, fascinating field.

## What You Want to Know — Told So You GET It

● These remarkable books lay before you — in compact, convenient, ready-reference form — the very essence of the world-renowned instruction in ELECTRICITY given at famous Coyne Electrical School. Coyne, you know, is one of the world's leading electrical schools where men are trained in electricity by actual shop work. These valuable Guides are built around this practical "Learn by Doing" course of training and are a thoroughly practical reference set for the most experienced electrical man — yet written so clearly and completely, they're an easy-to-follow course for the beginner! They'll aid you right on the job — or they'll help you prepare for a better job and bigger pay. 1,100 big pages, size 8½ by 11 inches. 2,000 subject listings in the handy index. Over 2,000 carefully-selected illustrations and diagrams so you can SEE HOW IT'S DONE while you READ HOW TO DO IT! Quick-Reference Celluloid Tab Index enables you to turn in a jiffy to any section.

- Some of the Subjects Covered in These Guides**
- Electricity, Magnetism
  - Signal Systems
  - Signal, Plan and Installation
  - Telephones
  - House Wiring, Code, Conductors
  - Power Wiring, Fuses, Switches
  - Illumination
  - Armature, and Stator Winding
  - Motor Repairs
  - D. C. Generators, Operation and Care
  - D. C. Switchboards and Meters
  - D. C. Motors and Controllers
  - A. C. Circuits and Calculations
  - A. C. Instruments, Power Factor Tests
  - A. C. Generators and Switchboards
  - A. C. Transformers
  - A. C. Motors and Maintenance
  - A. C. Rectifiers and Converters
  - A. C. Central Stations
  - A. C. Substations
  - Photo Cell Controls
  - Automotive Electricity
  - Electric Storage Batteries
  - Diesel Engine Operation and Care
  - Refrigeration Servicing
  - Air Conditioning
  - Radio Servicing
  - Public Address
  - Television

## FREE WITH GUIDES

### One Year of Personal Advice by Mail

Right now, with each set of Guides, I'm offering a service that may in itself pay for the Guides many times over! I'm offering one year's free advice by mail on any electrical problems. Yes, I mean that. The Coyne staff of experts will give you consultation service for one whole year! And this personal service won't cost you a single additional penny.



H. C. Lewis

## SEND NO MONEY

Just mail the coupon — that's all. No risk — no obligation. When books arrive, just pay few cents delivery charge. Keep the books 10 days. You'll be THRILLED. I promise, by this 10-day examination! After 10 days, if you decide to keep the books, send \$2 and then \$2 a month until advertised price of \$12 is paid. If you don't want them, return them at my expense within 10 days. Mail the coupon NOW while you can take advantage of this 10-Day Examination Offer!

H. C. LEWIS, President  
**COYNE ELECTRICAL SCHOOL**  
 500 S. PAULINA ST. Dept. 99-RE CHICAGO, ILL.

## Mail This Coupon Now

H. C. LEWIS, President  
 COYNE ELECTRICAL SCHOOL,  
 500 So. Paulina St., Dept. 99-RE, Chicago, Ill.  
 Send me the 3 Big Coyne Electrical Reference and Instruction Guides. I will pay the few cents delivery charges. Within 10 days after receiving the books, I'll either return them or send you \$2 and then \$2 a month until advertised price of \$12 is paid.

NAME.....  
 ADDRESS.....  
 CITY..... STATE.....

Please Say That You Saw It in RADIO-CRAFT

# For Better Servicing - - For Bigger Profits - - Use Gernsback Manuals and Books!



SINCE 1931 Servicemen have been buying more GERNSBACK OFFICIAL RADIO SERVICE MANUALS year after year. The authentic material, easily accessible diagrams and complete service data make them invaluable to dealers and radio Servicemen. *Without a Gernsback Service Manual at the repair job, there's time and profit lost.* Your service kit or laboratory is incomplete without all the GERNSBACK OFFICIAL RADIO SERVICE MANUALS. There are GERNSBACK MANUALS for servicing auto-radios, also refrigeration and air conditioning equipment.

**VOLUME 7 OFFICIAL RADIO SERVICE MANUAL**  
Over 1,800 Pages • Over 3,000 Illustrations • Stiff, Leatherette, Looseleaf Covers • Size 9 x 12 inches • Net Weight 10½ lbs. **\$10.00**

**1936 OFFICIAL RADIO SERVICE MANUAL**  
Over 1,200 Pages • Over 2,500 Illustrations • Stiff, Leatherette, Looseleaf Covers • Size 9 x 12 inches • Net Weight 8 lbs. **\$7.00**

**1935 OFFICIAL RADIO SERVICE MANUAL**  
Over 1,000 Pages • Over 3,000 Illustrations • Flexible, Leatherette, Looseleaf Covers • Size 9 x 12 inches • Net Weight 3¾ lbs. **\$7.00**

**1935 OFFICIAL AUTO-RADIO SERVICE MANUAL**  
Over 240 Pages • Over 500 Illustrations • Flexible, Leatherette, Looseleaf Covers • Size 9 x 12 inches • Net Weight 1¾ lbs. **\$2.50**

**1934 OFFICIAL RADIO SERVICE MANUAL**  
Over 400 Pages • Over 2,000 Illustrations • Flexible, Leatherette, Looseleaf Covers • Size 9 x 12 inches • Net Weight 2¾ lbs. **\$3.50**

**1932 OFFICIAL RADIO SERVICE MANUAL**  
Over 1,000 Pages • Over 2,000 Illustrations • Flexible, Leatherette, Looseleaf Covers. Size 9 x 12 inches • Net Weight 4¾ lbs. **\$5.00**

**OFFICIAL REFRIGERATION SERVICE MANUAL**  
(Volume 11)  
Over 352 Pages • Over 300 Illustrations • Flexible, Leatherette, Looseleaf Covers. Size 9 x 12 inches • Net Weight 1½ lbs. **\$5.00**

**OFFICIAL AIR CONDITIONING SERVICE MANUAL**  
Over 352 Pages • Over 600 Illustrations • Flexible, Leatherette, Looseleaf Covers. Size 9 x 12 inches • Net Weight 2¼ lbs. **\$5.00**

*To order these famous Manuals, see or write to your jobber or favorite mail order house. If more convenient, mail coupon directly to publishers.*

**RAD-CRAFT PUBLICATIONS, Inc.**  
99 HUDSON STREET NEW YORK, N. Y.

## Many New Books Have Been Added to RADIO-CRAFT LIBRARY SERIES

Get into the swing of reading instructive, authoritative books on technical subjects—radio, air conditioning and refrigeration. It's the easiest, quickest and most inexpensive way to improve your knowledge on these topics. In this series, popularly known as the RADIO-CRAFT LIBRARY SERIES, are all the titles necessary to your personal advancement. Only by careful study of these enlightening books, can you gain adequate experience in fields of radio, air conditioning and refrigeration. Each book is uniform. The volumes measure 6 x 9 inches—contain 64 pages, and have stiff, flexible covers. PRICE 50c PER BOOK. All books are sent to you postpaid.

### Here Are The Titles:

- |   |   |
|---|---|
| Book No. 2<br>MODERN VACUUM TUBES               | Book No. 18<br>POINT-TO-POINT RESISTANCE ANALYSIS   |
| Book No. 6<br>BRINGING ELECTRIC SETS UP-TO-DATE | Book No. 19<br>PRACTICAL RADIO KINKS AND SHORT CUTS |
| Book No. 13<br>ABC OF AIR CONDITIONING          | Book No. 20<br>THE CATHODE-RAY OSCILLOSCOPE         |
| Book No. 14<br>POCKET RADIO GUIDE               | Book No. 21<br>BREAKING INTO RADIO SERVICING        |
| Book No. 15<br>ABC OF REFRIGERATION             | Book No. 22<br>NEW RADIO QUESTIONS AND ANSWERS      |
| Book No. 16<br>PRACTICAL RADIO CIRCUITS         | Book No. 23<br>PRACTICAL PUBLIC ADDRESS             |
| Book No. 17<br>SERVICING WITH SET ANALYZERS     |   |

—EACH BOOK IN THIS SERIES—50c

RAD-CRAFT PUBLICATIONS, Inc., 99 HUDSON ST., NEW YORK, N. Y.  
Gentlemen: Enclosed find my remittance of \$..... for which send me, POSTPAID, the Manuals or Books indicated below by a cross (x) in the Panel.

- ( ) Volume 7 @ \$10.00 ( ) 1936 Manual @ \$7.00 ( ) 1935 Manual @ \$7.00  
( ) 1935 Auto-Manual @ \$2.50 ( ) 1934 Manual @ \$3.50 ( ) 1932 Manual @ \$5.00  
( ) Refrigeration Manual (Vol. 2) @ \$5.00 ( ) Air Conditioning Manual @ \$5.00

### RADIO-CRAFT LIBRARY SERIES @ 50c EACH

(Circle book numbers wanted: 2 6 13 14 15 16 17 18 19 20 21 22 23)

Name ..... Address .....  
City ..... State .....

(Send remittance in form of check or money order; register your letter if you send cash or unused U. S. Postage Stamps.) RC-1239

Please Say That You Saw It in RADIO-CRAFT



# RADIO-CRAFT

“RADIO'S GREATEST MAGAZINE”

## “STATIC-LESS” RADIO

By the Editor — HUGO GERNSBACK

**T**HE so-called static-less or frequency modulation system of broadcasting is a comparatively new arrival among the wonders of radio. Developed by the distinguished radio inventor, Major Edwin H. Armstrong, Professor of Electrical Engineering at Columbia University and also inventor of the superheterodyne and super-regeneration circuits, the new invention is likely to revolutionize, *in time*, all radio broadcasting as we know it today.

It is indeed a revelation to listen for the first time to a radio set operated on frequency modulation. The usual background noises, the frequent staccato-like sounds which punctuate the reception of practically every present-day radio set is completely absent in the frequency modulation receiver. The usual noises which we get from man-made static, such as clicks when we switch off or on electric lights, when an automobile passes, or when the elevator starts and stops, are all miraculously absent in the new receiver. We hear **ONLY** the sounds which originate in the broadcast studio. All extraneous electrical disturbances are kept out; so much so, that it is difficult to believe that you are listening to a radio set such as we have known since radio broadcasting began.

Laymen frequently ask the question, “What is the difference between the two methods of broadcasting?” The accepted and present-day means of broadcasting is technically termed *amplitude* modulation, in contrast to the new static-less *frequency* modulation.

Perhaps an analogy which I recently thought of in order to bring the point home to a number of non-technical people will explain the two methods.

Imagine a soft-rubber tube stretched from one end of a room to another. The walls of this rubber tube are so extremely thin and flexible that any slight change in air pressure at any point inside will cause the walls at that point to bulge. If now you attach a funnel at each end of the tube and speak into one funnel the sounds will travel through the tube and come out of the funnel at the other end. As you speak the voice “vibrates” the air within the tube. If, for the moment, we examine one small point inside the tube we find that this vibration is nothing more than an instantaneous increase in air pressure at this given point, followed almost immediately by a decrease in pressure.

The rate, or “frequency” of this compression or expansion of the air depends of course upon the pitch of the sound. Now since at each point along the tube where the pressure is increasing, the walls of the tube will correspondingly bulge, then as you look along the length of the tube from the outside you will see a series of increasing and decreasing bulges. We might say that the “amplitude” of the rubber tube is constantly changing. That is, at a given point it will be larger than the normal circumference and at another it may be smaller. The same sort of thing goes on if we imagine the rubber tube as a radio wave. In other words the human voice (or any other sound) being broadcast at the transmitter will change (modulate) the amplitude of the radio wave in accordance with the change in tone or pitch of the sound which is being impressed upon it. This system we call *amplitude* modulation.

Now let us imagine another sort of tube, this time a tube with *rigid* walls such as a metal pipe. Here as you talk into the tube there cannot be any bulging inasmuch as its circumference or “amplitude” is fixed. The air inside the tube nevertheless continues to act just as it did in the preceding analogy, that is, the frequency of vibration (compression or expansion) of the air continues to be a function of the pitch of the sound, but it can no longer affect the amplitude of the wave since the voice or sound affects (modulates) only the frequency of the air vibrations. This system we call *frequency* modulation.

While these two analogies are **NOT** exact ones in all particulars, they are better than any so far offered, and give a rough idea of what happens to our radio waves in space.

Since static, both natural and man-made, affects the amplitude of a radio wave and not its frequency, a frequency-modulated radio wave is entirely static-free. A moment's reflection will bring to mind definite proof of this statement. When operating an ordinary receiver (that is one with present-day amplitude modulation) during a lightning storm, you will remember that a crash of lightning manifests itself as a blast in the radio speaker, and not as a detuning of the station which would be the case if the lightning affected the frequency of the broadcast signal.

Frequency-modulated or “F.M.” stations which are now in the process of being opened in a number of points in this country have to work necessarily on a much lower wavelength than present-day broadcasting; usually on around 7 meters (or between 39 and 44 megacycles).

However, a number of tests have already been conducted on about 2½ meters and these have given rise to extraordinary results, even surpassing those on 7 meters.

Of course, all of us have always wanted static-less radio, free from all noises, and the advantages of such good reception are so tremendous that it will only be a matter of time before all radio stations will have adopted the new system.

Naturally, this is quite a revolutionary undertaking because it means that nearly 30 million radio receivers now operated in this country will have to be eventually scrapped because of the much superior results afforded by frequency-modulated receivers.

Late last month applications to the Federal Communications Commission were made to cover the New York area and another one to serve New England. These applications are not for experimental work, but for commercial stations. For several years now several experimental frequency-modulation stations have been operating and through the experience gained it is freely predicted that the new method of broadcasting is here to stay.

Already a number of radio set manufacturers have begun to turn out frequency-modulated receivers, and from all appearances, we are in for another radio boom during the next few years when the country will have to change-over from the present broadcasting means to the new one. For the New York area the static-less transmitter will have a 50,000-watt output and it will be situated on top of the New Jersey Palisades at Alpine. In New England the transmitter will be on top of Mt. Washington in New Hampshire, with a power of 5,000 watts. In the latter case, with only such a small output as 5,000 watts, it is expected to provide interference-free broadcasting for over 1,000,000 people in the northern part of New England. The reason for this is, of course, the high elevation of the transmitter on Mt. Washington.

At the present time there is in operation a 2,000 watt transmitter at Paxton, Mass., about 40 miles from Boston, with programs of about 16 hours daily. Major Armstrong's Alpine, New Jersey, station has been in operation for several years and was the pioneer station in this country. Other “F.M.” broadcast stations, which, however, are operating only experimentally, are at Meriden, Conn.; Springfield, Mass.; and Washington, D. C. Already, construction permits have been granted by the Federal Communications Commission for 14 other stations. Applications have also been filed for frequency modulation stations at Chicago, Los Angeles and San Francisco.

It is also quite certain that once these stations begin to operate on frequency modulation, television will not be very far away. The reason for this is, of course, that both television as well as frequency modulation work on short waves.

# THE RADIO MONTH



PHOTOCOCELL TELLY

Last month the directors of Chicago Television and Research Labs. announced a "cold light" television transmitter; and a receiving projector, of movie-screen-size images, employing a "photocell". The photocell depolarizes an arc-light beam. Shown in front of the bank of photocells at the transmitter, in the Hotel Sherman, is actress Hazel Benne.

## WAR NEWS

"WHERE is the British aircraft carrier hit by a German bomb in the North Sea?", "Why did Churchill say . . .?", etc., etc., queried a wandering German radio program, last month, when it landed smack-bang on top of a B.B.C. program.

The set of questions was directed to Winston Churchill, Britain's First Lord of the Admiralty, and asked for a reply within 2 hours. On the dot, 2 hours later, the same station again captured the B.B.C. wavelength just long enough to ask why no answer had been forthcoming.

If weather forecasts go sour more often, these days, we may lay part of the blame at the door of the European conflict. Reports from overseas are no longer being received from many countries. Trans-Atlantic airlines are depending upon confidential radio reports from London and Paris, and friendly governments; and foreign ships at sea, for fear of revealing their positions to submarines, have ceased broadcasting local weather reports.

The National Association of Broadcasters last month released an extensive set of rules voluntarily adopted by radio networks for handling war broadcasts. This move should eliminate any necessity for the F.C.C. to promulgate regulatory measures designed to achieve the results which these new rules should accomplish.



Dr. Francis J. Norton of the General Electric Co., investigates infinitesimal electric charges on invisible dielectric film only 1/10-millionth-inch thick, as described last month before a division of the American Chemical Society. Drawings (redrawn by *Radio-Craft*) from the *Review of Scientific Instruments* are shown at A and B. (See cover photo.)

Radio men in Tientsin, China, had an exciting time last month when Japanese raiders, purportedly looking for anything or anyone anti-Japanese, invaded the offices of the American radio service and the United Press, in the Radio Service Building; according to reports, American Consul-General John Caldwell officially protested this intrusion of American properties in the British Concession.

Hitler's recent veiled threat of having weapons more deadly than any now in use, last month led Dr. Antonio Longoria of Cleveland, Ohio, to state to a N. Y. *Daily Mirror* correspondent that he (Dr. Longoria) had several years previously developed a "death ray" which, discovered accidentally, shocked him with its potentialities; as a result, the ray machine had been dismantled. This discussion revives interest in the secret ray work reported in past issues of *Radio-Craft*; for example, the Marconi "death ray" mentioned in the August, 1935 issue.

## BROADCASTING

RECORDINGS of a program from station XERA were rejected as evidence in a slander suit last month. The complainant, a resident of Dallas, Tex., was not able to prove to the satisfaction of the judge, sitting in a Mexico City court, that the recordings were those of the program in dispute.

More than 60 mikes were used to handle the demands of the concluding broadcast of the "Columbia Workshop Festival," last month. A cast of 500 played to an audience of 75,000 spectators. During advance rehearsals, the various crowd reactions were recorded. These were combined with the usual "live" voices during the broadcast, swelling the total to the proportions of a mob of 10,000, for the mob scene.

## TELEVISION

**DX** RECEPTION of television 100 miles air-line to Schenectady, N. Y., was reported last month by the meteorological station on the summit of Whiteface Mountain which towers above Lake Placid, New York. Images were received on a 32-tube Stromberg-Carlson telly set with 12-in. image tube. Attempts are being made to receive the programs of the Empire State Building, 300 miles away.

This should not be impossible. Especially if a booster unit or preamplifier, such as will be described in a forthcoming issue of *Radio-Craft*, is used. European telly programs have been received in America, and vice versa; and last month television programs from the Rome, Italy, telly station (sight, 6.8 meters; sound, 7.4 meters), were reported to have been received in England.

In answer to a question by *Radio-Craft*, *QST* magazine last month stated that a transcontinental, coast-to-coast, 2-way contact was recently effected by phone on 56 megacycles (5 meters, approx.)!

Farnsworth's television set-up received a boost in color-movies, last month. Watch for *Popular Science* No. 3 (Paramount Pictures, Inc.).

Stage actress Virginia Campbell was reported in the press last month as being a "television 'casualty'"—the intense lighting during a telly broadcast being said to have caused first eye trouble, then severe headaches and sudden dizzy spells.

Allen B. Du Mont Labs. has been given an OK by the F.C.C. to put 50 watts of telly sight and sound on the air, in the band of 156 to 162 mc. (bandwidth includes sight and sound), from a portable mobile relay station to be operated in the N.Y. metropolitan area. Du Mont has for some time been experimenting with outdoor, direct pick-ups.

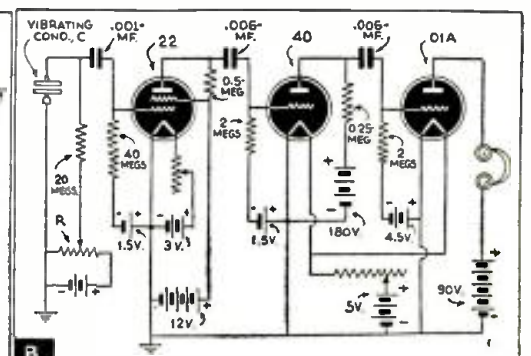
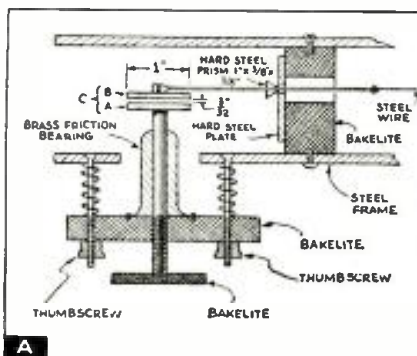

HEARING ELECTRICITY ON INVISIBLE BARIUM STEARATE FILM

The apparatus used by Dr. Norton included a vibrating, polished metal disc suspended just above the film (the condenser thus formed, and vibrated mechanically by a steel piano wire 18 inches long, is shown at A); a potential difference between disc and film resulted in an alternating current being fed into an audio frequency amplifier.

Minute voltages generated in the vibrating condenser shown at A are amplified as shown at B. Potentiometer R is adjusted for no-signal (applied potential difference balanced against contact potential difference). The natural electricity on the surface of water and on invisible insulating surfaces is thus converted to sound and studied with earphones.



# IN REVIEW

*Des Moines, Iowa*, may soon have a telly station on the air. The F.C.C. has received the application of R. B. Eaton, for a 100 W. station in the 44 to 50 mc. band.

**Television on a sailboat!** Last month Dr. Thomas Goldsmith set up a television receiver aboard *The Great Circle*, a 35-ft. sailboat owned by George H. Gibson. Off Huntington, in Long Island Sound, N.B.C.'s telly programs were received very well, although the point of origin was 35 miles away.

A gasoline-driven generator delivered 110 V. A.C. to the receiver. Fading, as the boat moved around, required the direction of the dipole antenna to be corrected, from time-to-time. Dr. Goldsmith heads the engineering activities of Allen B. Du Mont Labs.

*WCAU Broadcasting Co.*, Philadelphia, Pa., last month applied for permission to set up a telly station at a site, in Philly, to be determined. Band: 78-84 mc.; power: 1 kw.

## FREQUENCY MODULATION

**"FREQUENCY Modulation in Television Transmission"** was the title of a paper presented before a meeting of the Institute of Radio Engineers, Emporium Section, last month, by C. W. Carnahan of Hygrade Sylvania Corp. The following brief outline of the paper was prepared for *Radio-Craft*.

A frequency modulation system was examined in comparison with present amplitude modulation systems as a transmission system for television. It was found that bandwidth requirements are met equally well in both systems provided that the overall frequency characteristics of the R.F. amplifiers are the same.

Power output and final stage efficiency in a frequency-modulated transmitter may be doubled over that of existing amplitude-modulated transmitters. "F.M." offers advantages in synchronization.

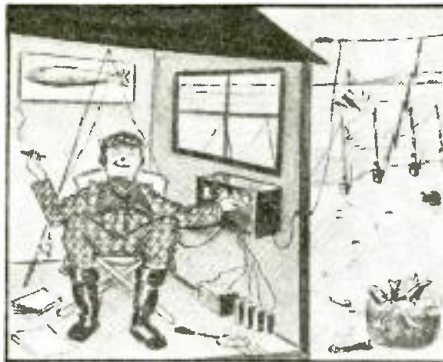

**RADIO ICE-FISHING**

Whether he's indoors or out, Mr. O. P. Eggleston, a Theresa, N. Y., inventor, easily keeps tabs on 15 or 20 lines, when ice-fishing, a *U.P.* report stated last month. A fish bite sets off a device which discharges a .22 cartridge, waves a red flag, rings a bell, lights a lamp and sends out shortwave radio signals!



**TELLY 'SCOPE**

General Electric engineers have developed an oscilloscope for television work. The instrument is designed to meet the need in this field for an oscilloscope having means for both horizontal and vertical deflection capable of handling the wide range of frequencies encountered. (See photo on cover.) (More data on pg. 351.)

## SOUND

**DR. WALTER DAMROSCH** last month was the guest of honor at the formal opening of the Hammond Organ Studios in the Hammond Bldg. in New York City. Concert music was presented. Electronic music had its innings in a special arrangement of George Gershwin's "Rhapsody in Blue" for 4 Novachords and Hammond Organ.

*Radio-controlled air-raid sirens* are the latest thing in alarm devices, in Manchester, England, stated *Practical and Amateur Wireless* (London), last month. Simultaneous or independent control is available from a central transmitter.

*"So-o-o-ey, Boss"* a Libertyville, Ill., farmhand now murmurs into a mike. Amplified, the call clarions from outdoor loudspeakers and assails the receptive ears of cows in pasture. The docile bovines then saunter into the milkshed for milking, an *A.P.* report last month stated.

*Columnist Leonard Carlton* last month reported that N.B.C.'s Washington stations introduced an ingenious "we will call you" service for rabid war-news fans. Listeners were advised to leave their sets turned on and then retire, after the broadcaster went off the air at 1 A.M., and the listeners would be

awakened by a piercing squeal if the station had a news flash that warranted putting the station again on the air.

*Public address cars* now race through Paris streets, during air raid protection practice, warning Parisians to seek shelter.

*'Tis claimed* that the cackling in the henhouse of Frank Singiser, WOR newscaster, was at ebb during the early days of World War II, last month. Accustomed to hearing lively musical programs, the hens went on a sit-down-but-no-eggs strike when poultry hands rode the gain, and tuning, to accommodate news programs, at the Singiser farm, instead of music.

## SHORT WAVES

**CUPID** shot ether arrows for 3 years before Miss Mildred Tate of Victoria, B. C., succumbed to the radio importunings of Richard C. Young of Yakima, Wash., last month, and said "Yes!" Both radio amateurs, they were surprised, etc., indeed, when brother hams in many places, who had been following the romance, mailed them congrats. *Radio-Craft* wishes these two radio amateurs the very best of luck.

Walton H. Bostwick of Plainfield, (Continued on page 351)



**N.B.C. MASTER CONTROL**

Like the railroad dispatcher who switches his trains on one line, N.B.C.'s new portable master control unit permits programs emanating at up to 10 different microphone positions to be instantly connected at will over a single wire.



**C.B.S. CUE MACHINE**

This automatic cueing flash was introduced, last month, by C.B.S. engineers to warn announcers and news analysts at the end of their speaking time. The dial is calibrated in minutes; the center knob is marked in seconds.





# RADIO AIDS U.S. WAR MACHINE

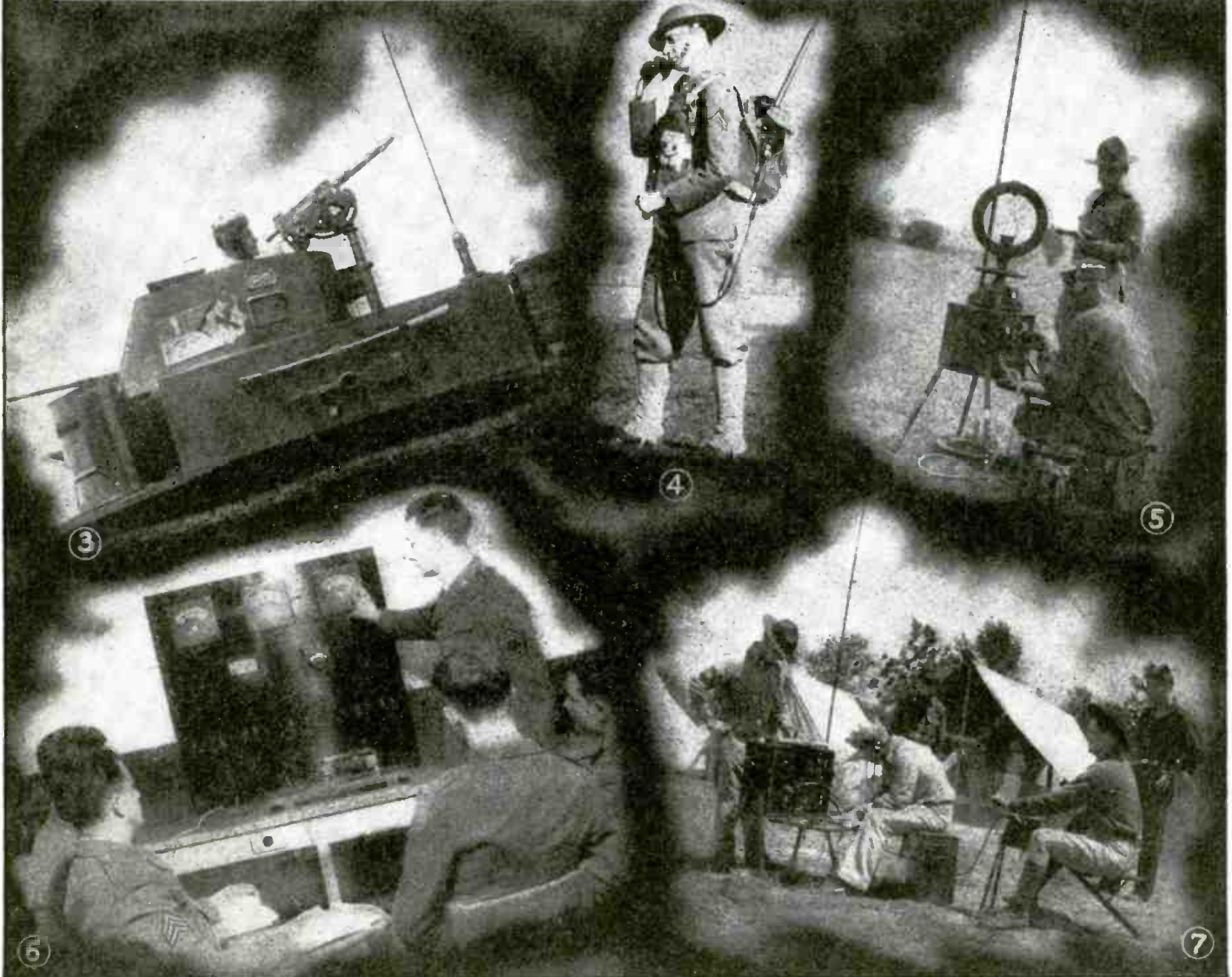

United States Army, Navy and Signal Corps adaptations of radio on land and sea, in the air, and below the sea have been illustrated and described in past issues of *Radio-Craft*. Facsimile, radio typewriters, throat microphones, super-power (20-mile) loudspeakers; radio-controlled airplanes, guns, torpedoes and other devices; cathode-ray flying instruments, television equipment, and many other radio instrumentalities have been perfected but are seldom publicized. Few photos of our military activities, incorporating radio, have been released by Uncle Sam's Recruiting Offices since most of these developments are on the "Restricted" list. On the cover of this issue of *Radio-Craft* are shown radio-equipped tanks in action, with each tank under direct control of the unit

commander by radiophone. Descriptions of the photos shown above follow. (1) Squadron of high-speed, long-range scouting machines in formation flight; arrow indicates one of the antennas of the 2-way radio system. (2) U. S. Army Air Corps observation plane equipped with 2-way radiophone. (3) The "mechanized cavalry" is radio-equipped; note fishpole antenna. (4) The Army's "walkie-talkie" 2-way radiophone permits instant and individual direction of infantry. (5) An important use of the Signal Corps' goniometric field loop-set is in locating enemy transmitters. (6) Sgt. Brown instructs recruits at the Signal Corps School. (7) Field radio station during War Games at Plattsburg, N. Y., last month; note hand-generator power supply unit at right.



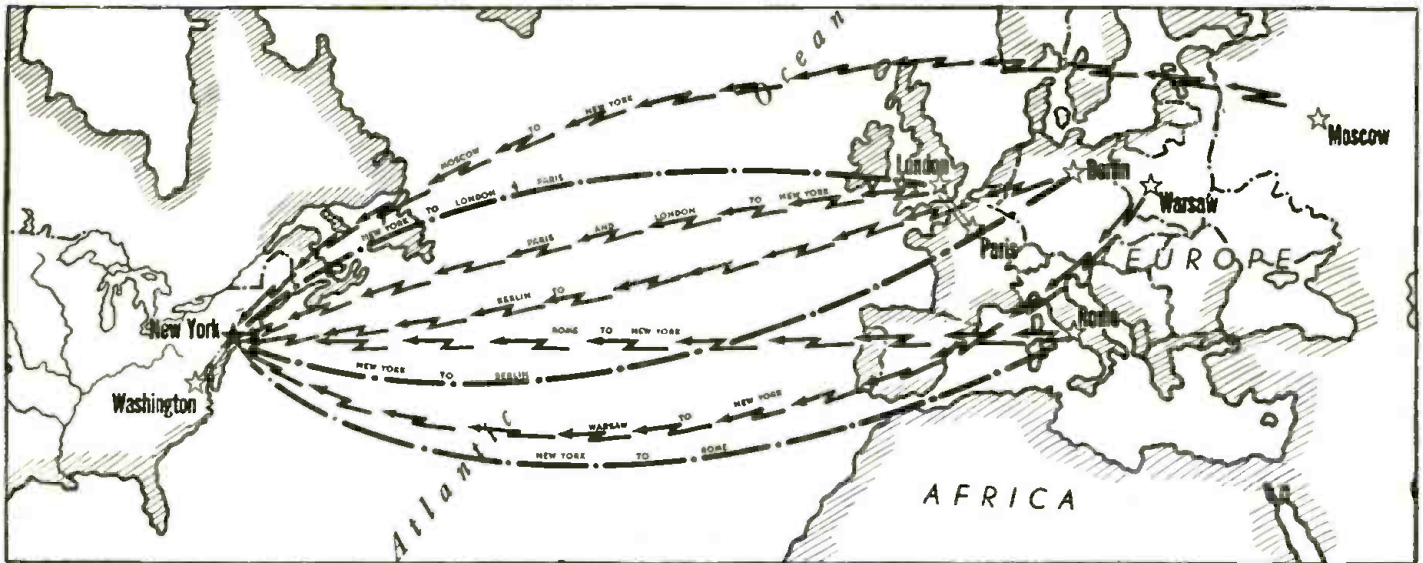

The zig-zag lines show shortwave air channels from Europe; dash-dot lines, cue facilities from New York to Europe; dash lines, communications facilities. A 4-way conversation may be held with London, Paris, New York and Washington; only 2 radio channels—one East-bound and one West-bound—are utilized between Europe and America. International talk-fest may include other foci of war news for broadcast listeners as C.B.S. shows in this map.

## WAR NEWS Via RADIO

*Modern radio broadcast coverage of war news utilizes many technical innovations. Several, including "4-way conversations", are described in this article on how C.B.S. is set up for feeding news to its network.*

**I**N a glass-enclosed studio on the 17th floor of the Columbia Broadcasting System, a modern miracle of radio is taking place.

Seated at a desk before a microphone is the veteran news analyst, H. V. Kaltenborn. Strapped to his head is a set of earphones. He is delivering an analysis of the latest war bulletin. As he speaks, his words are being heard by millions of American radio listeners. They are also being heard by 3 other men—one seated at a microphone in Washington, D. C., another at a microphone in Paris, a third in a radio studio in London. As we shall see, the result is a transoceanic "radio party-wire"!

### MULTI-POINT CONTACT PROBLEMS

In 2 minutes, Kaltenborn's analysis will end. He will lean forward into the microphone, and with no change in his tone of voice, will say:—"Come in, London." And without a pause in the even flow of broadcasting, the man in London will reply. In due course, the voice from London will give way to the voice in Paris, and that voice to the voice in Washington, D. C.—as smoothly as though all the men were seated in a single living-room, chatting about the news.

Such is Columbia's latest technical innovation for the coverage of war news—the "4-way conversation" as it has

been called by the engineers and traffic men who worked it out and made it possible.

The need for the multi-point conversation was first felt at C.B.S. in March, 1938, when the Austrian *Anschluss* began. At that time, Paul W. White, Director of Public Affairs, realized that straight broadcasts from abroad were not enough. In time of crisis the foreign countries were liable to impose censorship on all broadcasts delivered from their studios. To counteract such propaganda, it was necessary to have not one but several foreign pick-ups at a time.

White did arrange several such multi-  
*(Continued on page 374)*

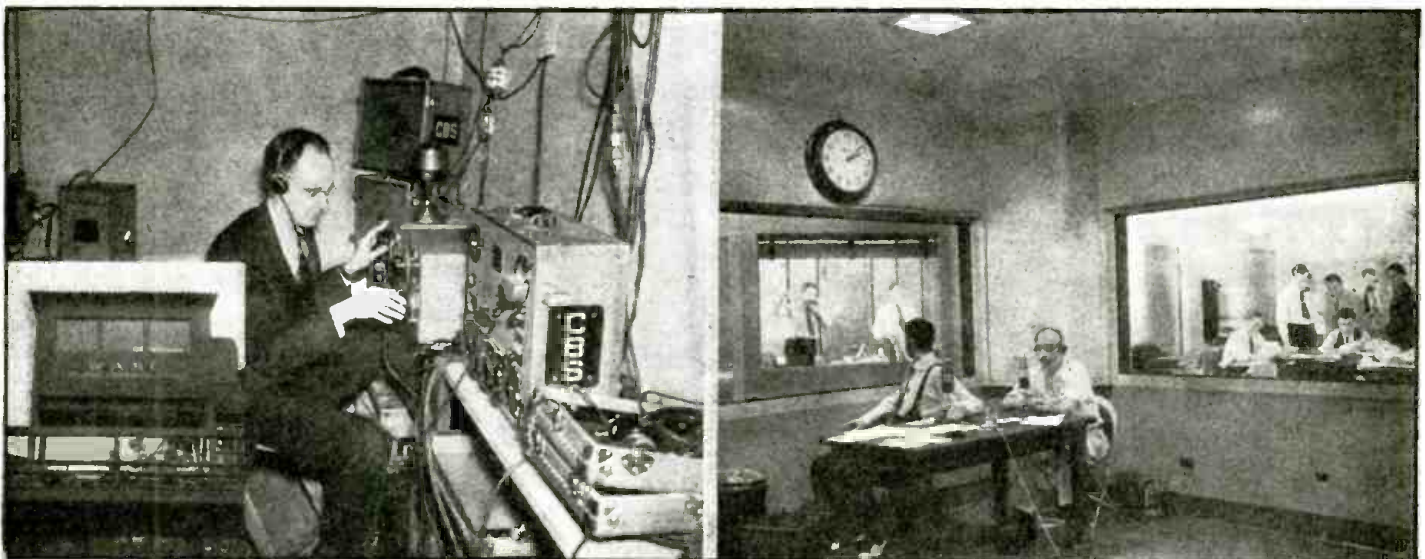

The DX listening post which the Columbia Broadcasting System maintains 24 hours per day to aid its news-gathering staff includes the super-sensitive receiving equipment here shown, left, being operated by Mr. William Whitford; the exterior of this station, at an ideal location in Forest Hills, Long Island (N.Y.), is shown in inset. Studio 9 (photo at right), 17th floor, 485 Madison Ave. (N.Y.C.), is a special news-broadcasting unit built this year by C.B.S.; the side at left faces public affairs director White's glass-enclosed office, the side at right faces the news-room, while straight ahead is the control room. At the studio mikes are announcer Bob Trout and news analyst Elmer Davis.

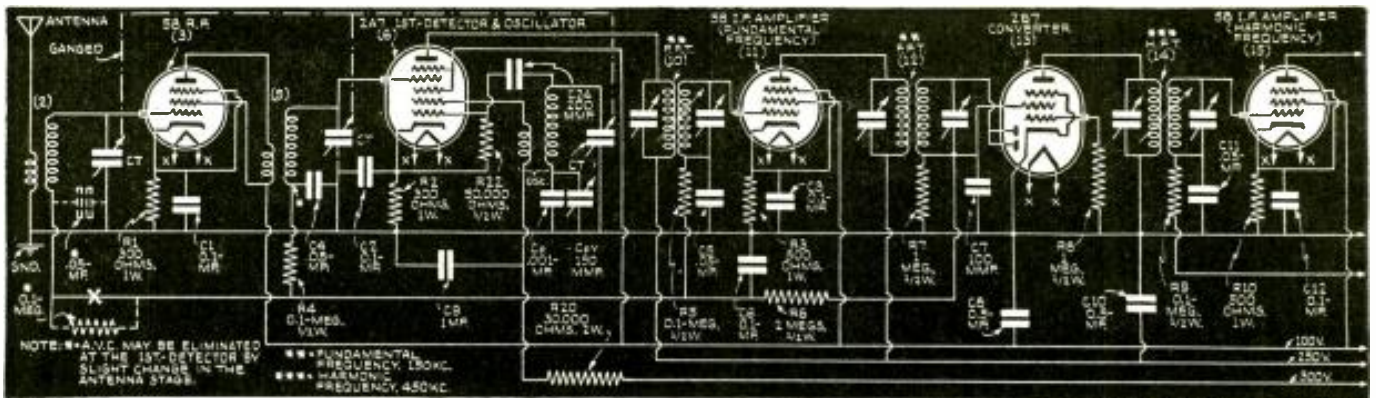

Fig. 1. "Frequency tripler" tube 13 is the "heart" of this receiver, for it converts the signal from one I.F. to another, with resulting advantages.

## NEWEST HI-FI 9-TUBE SUPERHET.

*Here's the description of a "3rd-Harmonic Superheterodyne" for which many advantages to have been allowed. The author offers oscillographic analyses in proving his claim*

P. WILSON

### FEATURES—

1. Higher fidelity with, at the same time, a higher degree of selectivity.
2. Sensitivity greater than 1/10-microvolt-per-meter on the high-fidelity position!
3. Dual I.F. channels.
4. Dual A.V.C. circuits.
5. Extremely-low noise level.
6. Audio-frequency response substantially flat (*in the tuner*) from below 15 c.p.s. to well above 15,000 c.p.s.
7. Self-phasing characteristic of circuit tends to eliminate audio phase distortion.
8. One I.F. transformer controls the selectivity.
9. New-type automatic volume control.
10. Less "background blast" when selective fading occurs.
11. Selective automatic volume expansion.
12. Steep-sided resonance.
13. Carrier wave is exalted (raised to a higher gain level) in the tuner.
14. Carrier wave is electronically converted from a fundamental I.F. to a 3rd-harmonic I.F.

EVERYONE today is wishing he had a radio receiver that would have really natural tone, yet would have very low noise level with high sensitivity, so that he could "reach out" and receive distant stations with good tone quality. Such a receiver will now be described.

### DUAL I.F. CHANNELS

This receiver uses 2 intermediate-frequency amplifiers! One I.F. amplifier operates at the initial or fundamental I.F. and the other at a harmonic of this frequency. The 1st I.F. amplifier channel therefore is no different from the ordinary receiver's I.F. section (see Fig. 1); the 2nd I.F. amplifier channel, however, is tuned to a harmonic of the 1st amplifier. (The 3rd-harmonic was chosen because it was found to be preferable for various reasons.) The use of these 2 amplifiers constitutes the basis of U.S. Patent No. 2,140,141, all claims in which were recently granted to the writer.

Harmonics are not generated signals but are the natural by-product of an oscillating circuit. The modulation on the harmonic, due to modulation on the fundamental, not only exactly follows the modulation on the fundamental but also, in this receiver, has a tendency to phase itself at both the high and low audio frequencies. This results in amazingly natural tone reproduction.

The 2nd or harmonic amplifier gives the receiver additional amplification and is also broadened to a bandwidth of 30 kc. to afford high-fidelity reception.

### DUAL A.V.C. CIRCUITS

The diodes at the 2nd-detector are used to rectify the signal for automatic gain control, as well as for detecting audio frequencies.

As you already may have noticed, there are 2 separate A.V.C. actions in this receiver. The 1st A.V.C. action isn't sufficient for our needs.

Figure 2C shows how the carrier wave is exalted, or raised to a higher gain level; the oscilloscope signal is taken first from the diode of the 1st amplifier, then from the diode of the 2nd amplifier. The increase in the carrier-wave gain is due to the increase in gain without increase in hiss or noise, in the harmonic amplifier.

The fundamental frequency with a bandwidth of 10 kc. will reflect a bandwidth of 30 kc. on the harmonic frequency (see Fig. 3). By using this method a greater audio range is realized. By aligning the harmonic amplifier for a bandwidth of 30 kc., transformer 10 can be used to control the selectivity of the whole receiver. The selectivity and fidelity characteristics are then as shown in Fig. 2A.

All the transformers used in this receiver should be

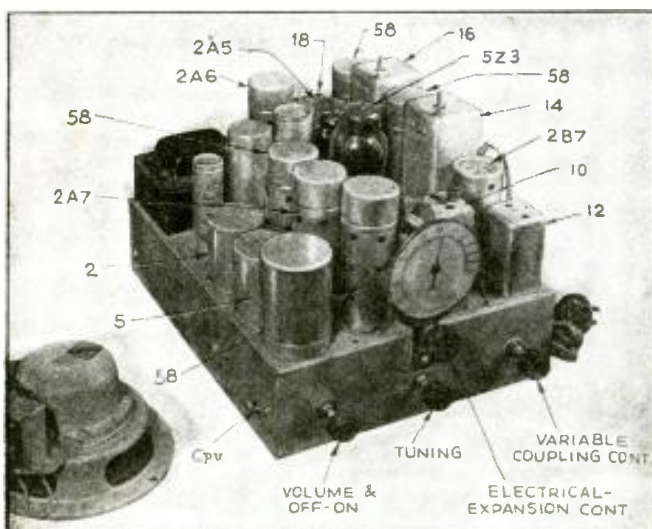

Arrangements of the components of one of 3 "3rd-Harmonic Superheterodynes" built by Mr. Redcay. Cabinetry may be chosen to suit.



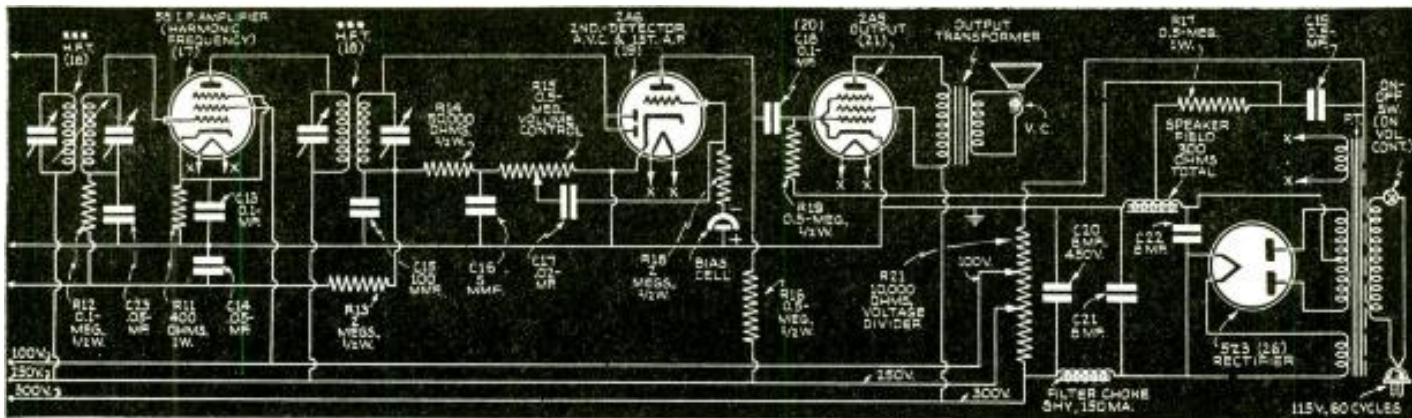

Fig. 1 (continued). The remainder of the circuit is designed to maintain an A.F. signal, to speaker voice coil, out of 20,000 cycles!

# INTRODUCES "HARMONIC CONVERSION"

are claimed. It constitutes U.S. Pat. No. 1,040,141, on which all claims are said of DX reception with higher fidelity and lower noise; and circuit A.F. reponse to 20 kc.

## RED CAY

air-tuned to avoid drift; also, the oscillator should be placed so that the drift will be minimized. The oscillator plate voltage should be taken from a higher voltage and dropped to the desired voltage through a bleeder resistor bypassed with a 1 mf. condenser. This amount of filtering will also help prevent the oscillator from passing-through the frequency of the harmonic amplifier when fixed at a very high frequency of around 1,400 to 1,500 kc.

## SELECTIVITY

Transformer 10 (Fig. 1) is shown variable, but, electrical band-expansion can be used in its place. The degrees of expansion are clearly shown in Fig. 2A—SHARP, MEDIUM, and BROAD. Transformers 14 and 16 also have variable coupling. This was decided upon to make alignment easier; and the shift from "extreme selectivity" to "high fidelity." With all the transformers fixed to receive "extreme selectivity," the selectivity is approximately  $\pm 2$  kc. off-resonance.

The diagram designated as Fig. 4 shows the method of circuit filtering preferred by the author; its use will greatly reduce the tendency toward frequency modulation (which would cause annoying distortion to occur) with large percentages of modulation. This circuit will also reduce feedback troubles; and will stabilize the I.F. stages to avoid frequency drift.

## THE HEART OF THE RECEIVER

The "heart" of this receiver is the harmonic conversion tube, 13, Fig. 1. This tube acts as a "dummy antenna" to pick from the fundamental frequency the selected harmonic. In order that the modulation on the harmonic amplifier does not distort or become very rough,

the diodes are used to rectify the fundamental frequency.

This type of detection is linear as long as the load resistor is correct. (See Fig. 1, resistor R7. Different values of resistors will have to be used to determine the correct load required for high percentages of modulation.) The negative portion of this rectifier signal is used to automatically control the gain of the fundamental frequency. At this point you will notice that the screen-grid of tube 13 is connected to the high end of the diode load resistor. This resistor in series with the control-grid of tube 13 is used to reduce the noise or conversion-gain noise level to a very low value. This also decreases the distortion at very low signal levels.

Figure 5 shows a diagram of the vital element in the receiver. During rectification, the positive halves of the signal are lost. The negative halves are used for A.V.C. and supply the rest of the receiver with a pure modulated harmonic signal.

Inside the tube the signal flows from the screen-grid to the anode. The screen-grid is connected to the diode impedance instead of being connected directly to the diode plates. The pick-up is caused by interelectrode capacity from diode and screen-grid to the anode.

Due to the low output of tube 13 on the harmonic frequency, at very low signal inputs to the antenna post, transformers 14 and 16 should have variable coupling. (Using plain transformers, then detuning or staggering them, will cause considerable loss in gain; therefore, I strongly urge the use of band-expansion transformers in this circuit throughout. *Not plain transformers.*) If the input to the antenna post is 1/10-

(Continued on following page)

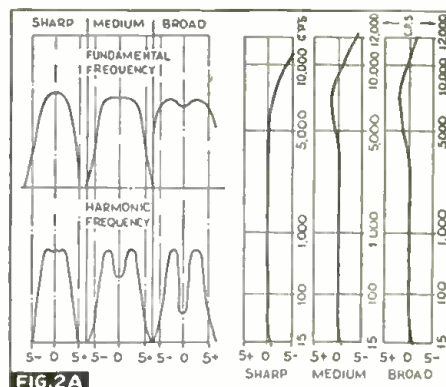

FIG. 2A

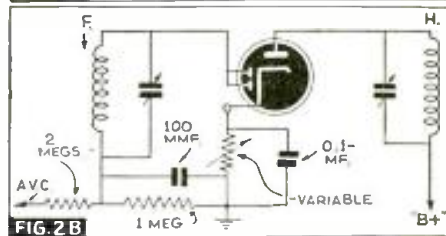

FIG. 2B

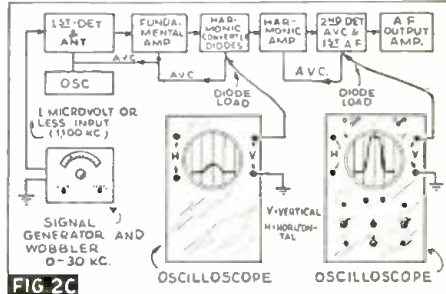

FIG. 2C

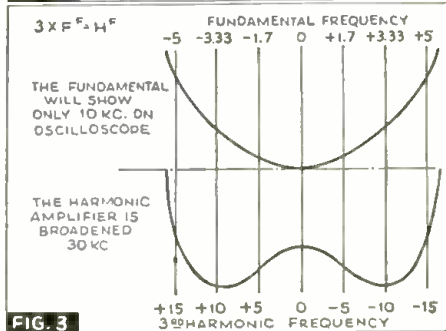

FIG. 3

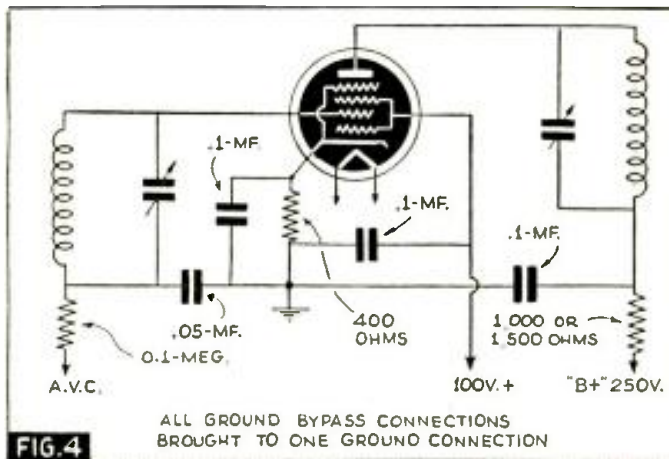

FIG. 4 ALL GROUND BYPASS CONNECTIONS BROUGHT TO ONE GROUND CONNECTION

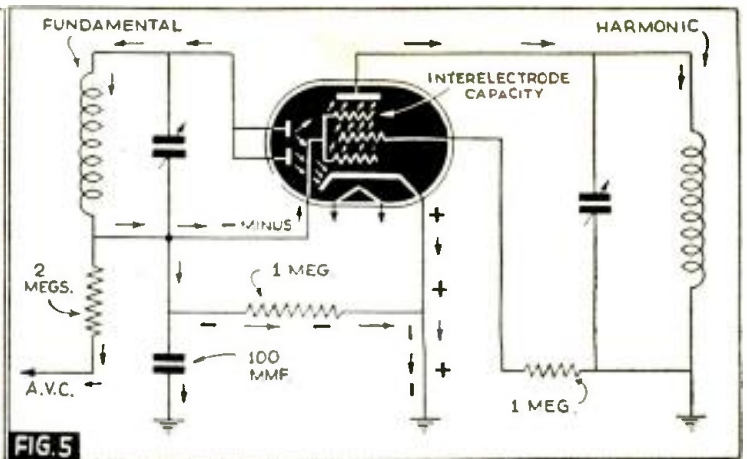

FIG. 5

(Continued from preceding page)

microvolt (or 1/10-millionth of 1 volt) the output to the harmonic amplifier, with the proper conversion gain, will be less than 500 microvolts. This will be sufficient input to the harmonic amplifier to work the A.V.C.

The tube (13, Fig. 1) in the converter stage that is used to change the signal from the fundamental frequency to the harmonic frequency, should not be allowed to draw current in the pentode section (as in Figs. 1, 2B, and 5) as this causes thermal agitation (hiss) without the slightest conversion gain or increase in sensitivity. The resistor in the control-grid of tube 13, Fig. 1, prevents the tube from taking on current during modulation (or any other time). This minimizes the noise that is set up during very low signal voltages that appear at the antenna post of the receiver. Relying on the interelectrode capacities for conversion results in very low noise at low signal levels.

In Fig. 2B there is a \*special tube used to change the signal from the fundamental frequency to the harmonic frequency. In this special tube there is sufficient interelectrode capacity for the proper conversion gain with the least noise.

### SENSITIVITY

The sensitivity was measured side-by-side with a properly-aligned, 23-tube high-fidelity receiver, of a well-known manufacturer, with startling results.

A signal from a signal generator was fed to each of the receivers through the antenna posts with normal output. This signal was then reduced to approximately 1 microvolt-per-meter output. The 23-tube receiver scarcely received the signal, with the selectivity control in the maximum position, while the 9-tube receiver under discussion picked up the signal with perfect modulation and about 1/10th the noise. (The 9-tube receiver made all these tests on the HIGH-FIDELITY position.) All these tests were made with 30% modulation.

The signal generator was then turned to approximately 1/10-microvolt signal. The 23-tube receiver passed over the basic frequency with no response while the 9-tube receiver worked the A.V.C. on the harmonic amplifier, and the modulation could be clearly heard with the volume control setting remaining unchanged. The modulation measured at the 2nd-detector dropped only about 5%.

Finally, with the attenuator turned-off of the tap, the signal was reduced to less than 1/10-microvolt and the 9-tube receiver still received the signal with the modulation audible and the A.V.C. action on the harmonic amplifier still working.

With a signal input of about 2 microvolts the whole audio range remained constant the same as with a 0.1-volt input. At 2 microvolts input there was only a slight background hiss or the thermal agitation.

The young radio engineer who would like to experiment with a new television receiver for video frequencies, will get a thrill out of a set built along these lines. Much greater distances will be covered than with conventional receivers. The frequency of the 2 I.F. amplifier channels will have to be changed to a higher frequency; and the harmonic-frequency transformers will need to be made to pass a wider bandwidth.

Further (daytime) tests were made by using a 1-meter antenna (3 ft., 3 ins.) with amazing results. The New York stations—WEAF, WOR, WJZ, WABC, etc.—which are approximately 100 miles from my home town were received with a slight background noise. The Philadelphia stations are approximately 50 miles from my location. The stations further than 100 miles (like WPG and WDEL) were very well received. Stations 120 miles distant were heard with very good tone quality with the same, 1-meter-long antenna.

### ALIGNMENT

The method used by the author to align this type receiver is as follows.

First, set the signal generator to the harmonic frequency, and modulate this to a bandwidth of 30 kc. With the oscilloscope connected to the output of tube 19, sweep the 450 kc. amplifier from 435 kc. to 465 kc. The signal generator is connected to the control-grid of tube 13 through a series coupling condenser of approximately 0.1-mf. Bring all the stages to the basic frequency, starting with transformer 18, Fig. 1.

Now leave the signal generator on the control-grid of tube 13 and change the frequency setting to 150 kc. or the fundamental frequency. This will show a much sharper response curve on the screen of the oscilloscope. Broaden the selectivity of transformers 14 and 16 to give a bandwidth of 11 kc. (5.5 kc. off-resonance). This will result in a double dip or 2 peaks. If the 2 peaks are unbalanced, adjust the primary of transformer 18 until the peaks have the same height.

The next step in alignment is to change the input of the signal generator from the control-grid of tube 13 to the control-grid of tube 6. Increase the output of the signal generator and swing the frequency from side-to-side until the output at tube 19 centers on the screen of the oscilloscope. When the image is centered on the screen of the oscilloscope take the "vertical" connection from the diode load on tube 19 and clip it onto tube 13's diode load resistor. Adjust transformers 10 and 12 with the selectivity control set to the SELECTIVE position.

After these adjustments are made put the "vertical" input to the oscilloscope on the diode load resistor on tube 19 and re-center the image on the screen. Return the connection on tube 13 and readjust transformers 10 and 12.

Alignment of the detector and oscillator sections with the R.F. or antenna stage is made in the usual manner. After the alignment is finished set the signal generator to approximately 1,000 kc., feed this signal to the antenna post of the receiver, and sweep this signal 15 kc. broad. With the "vertical" connection on the diode load of tube 19, the resulting curves should correspond to those shown in Fig. 2A. I strongly urge the use of a cathode-ray oscilloscope for aligning this type of receiver. Misalignment will cause serious audio distortion.

The use of either tuning "eyes," or meters, in tuning this receiver will give greater accuracy in tuning; on SELECTIVITY, the position of resonance cannot be determined by ear. Such indicators will also show the functions of the 2 separate A.V.C. actions.

This receiver is one of 3 to be built to date; they differ mainly in the A.F. section. However in the largest job, an 18-tube receiver, 2 electron "eyes" are used to indicate the basic frequency (resonance), and the 2 separate A.V.C. actions.

### A.F. RESPONSE IN THE TUNER

In recent electrical tests the frequency range, with the receiver set in the BROAD position, extended from 15 to 10,000 c.p.s., flat, with a slight drop to 12,000 c.p.s. Audio frequencies as high as 20,000 c.p.s. were measurable, believe it or not. (See Fig. 2A.) On the SELECTIVE position, the frequency range started well below 15 c.p.s. and extended well above 5,000 c.p.s., flat, with a slight drop to 9,000 c.p.s. The MEDIUM tap has a range between these two extremes and is also used to obtain good tone with very little interference from the adjacent-channel stations.

### LOW NOISE LEVEL

The noise level with the receiver in the SELECTIVE position is extremely low. The noise on the SELECTIVE position with a signal input as low as 1/4-microvolt is not even noticeable. On the HIGH-FIDELITY position, the noise on extremely low signal inputs, does not follow the high audio frequencies as they do with the modern receivers on the market today. *The natural static is lowered by more than 50% over the other receivers!* For police radios, I think this is the last word in efficient, dependable receiver design. Because of the low noise level and the new A.V.C. action not a word given to the cars would be missed.

(Continued on page 372)

\*When this 3rd-Harmonic Superhet circuit becomes better known tube manufacturers will bring such a multi-element tube to the attention of radio engineers.—Author



# 4th GROUP of PRIZE WINNERS

## Radio-Craft's P.A. Contest

*Servicemen, radio dealers and sound specialists are also given the article which won the 1st Prize in the Fourth Section of RADIO-CRAFT'S \$4,000 P.A. Contest. This winner shows how the skillful handling of rental P.A. systems is a money-maker for sound men.*

**1ST PRIZE**—30-40 W. Complete P.A. System, \$150.

*Offered by Radio Wire Television, Inc. (Formerly, Wholesale Radio Service Company)*

Won by Merrill Lindley, 2659 Napoleon St., Indianapolis, Ind.

**2ND PRIZE**—"Filmgraph" model A, \$149.50

*Offered by Miles Reproducer Co., Inc.*

Won by Roscoe B. Tallman, 702 Radcliffe, University City, Mo.

**3RD PRIZE**—Airline Marine-Type Speaker, \$62.

*Offered by Montgomery Ward & Company.*

Won by Edward H. Gordon, LeClaire Hotel, Moline, Ill.

**4TH PRIZE**—Set of Low-Pass, Band-Pass and High-Pass Amplifier Filters, \$61.

*Offered by Amplifier Co. of America.*

Won by Keeshan Advertising Service, Manhattan, Kans.

**5TH PRIZE**—15-W. De luxe Amplifier, type AM-15, \$57.

*Offered by Amplitude Products Company.*

Won by Frederick Urlan Dillon, Technical Radio Laboratory, 1224 Horne Ave., Hollywood, Calif.

**6TH PRIZE**—5-W. Complete P.A. System, type 32-06PX, \$55.80.

*Offered by Vocograph Sound Systems.*

*(This prize is not being awarded inasmuch as the company has since gone out of business.)*

**7TH PRIZE**—Permanent Magnet Speaker Unit, No. 7, \$52.50.

*Offered by Fox Sound Equipment Corp.*

Won by Vern Ware, Vern Ware Radio Service, 1728 N.W. Drive, Des Moines, Iowa.

**8TH PRIZE**—Velocity Microphone, type RBHK, \$42.

*Offered by Amperite Company*

Won by Allied Engineering Services Co., 410 Marion Ave., Lima, Ohio.

**9TH PRIZE**—Velocity Microphone, model 50, \$40.

*Offered by Allied-Burns Company.*

Won by Roy S. Ruggles, 4 Williams Terrace, Bellows Falls, Vt.

**10TH PRIZE**—Transducer Microphone, \$27.50.

*Offered by Radolek Company.*

Won by Walter H. Johnson, 913 19th St., Jackson, Mich.

**1ST 11TH PRIZE**—Velocity Microphone, model 30, \$22.50.

*Offered by Allied-Burns Company.*

Won by Robert H. Lehfeldt, Flagler Radio Co., Inc., 1068 W. Flagler St., Miami, Fla.

**2ND 11TH PRIZE**—Auto-Top Carrier for Mobile

Sound Installations, platform size 30 x 54 ins., type PA26, \$22.50.

*Offered by Vac-O-Grip Company.*

Won by L. B. Tooley, 306 N. Lafayette, Clarksville, Tex.

**1ST 12TH PRIZE**—Auto-Top Carrier for Mobile Sound Installations, platform size 30 x 36 ins., type PA22, \$16.

*Offered by Vac-O-Grip Company.*

Won by Wm. N. Hunter, 635 Emery St., London, Ont., Canada.

**2ND 12TH PRIZE**—12-In. P.M. Speaker, type FB12-M, \$15.50.

*Offered by Cinaudagraph Corp.*

Won by Lowell D. Harlan, Box 283, Clearfield, Iowa.

**3RD 12TH PRIZE**—12-In. P.M. Speaker, type FB12-M, \$15.50.

*Offered by Cinaudagraph Corp.*

Won by Amos Bolin, 8030 Twoot Ave., Kansas City, Mo.

**1ST 13TH PRIZE**—Floor-Type Chrome Microphone Stand, model EF-17, \$12.50.

*Offered by Eastern Mike-Stand Company.*

Won by Arthur C. McIver, 876 Hunter St., S.W., Atlanta, Ga.

**2ND 13TH PRIZE**—Floor-Type Chrome Microphone Stand, model EF-17, \$12.50.

*Offered by Eastern Mike-Stand Company.*

Won by Swen Bolin, 8030 Twoot Ave., Kansas City, Mo.

## THIS IS THE FIRST-PRIZE MANUSCRIPT

**R**EMEMBER when renting P.A. systems was considered a profitable side line? To-day that condition has vanished; because of the low prices of good P.A. systems many individuals and organizations have purchased them and now furnish the systems gratis.

On the nights of Aug. 12th and 19th I had a 2-night P.A. stand at a church social resulting in \$18 with a net profit of \$16.50 in spite of the church having their own system and offers of free outfits.

I solicited merchants in the vicinity asking them \$3 each, in return for short announcements on the P.A. system and their names listed on a sign displayed on the grounds. This gave the merchants audio and visual advertising which combination is the most thorough method of advertising obtainable.

This type of P.A. rental (church

fairs, lawn socials, picnics, etc.) requires skillful handling of the mike and recorded music. Early in the evening I use music with some announcements. When the bulk of the crowd arrives I cut out the music in order not to overdo the music. The short announcements prove very effective as it is possible to direct crowds to certain stands, sell items such as candy, ice cream, etc., which are moving slowly. I have even recovered lost children. This type of service makes the P.A. a very valuable and necessary part of the social. As the crowd thins out I play music (which helps hold the crowd) and push items not selling. I buy a few of the latest song hits each year which keeps my record library up to date with old and new tunes.

I use crystal mikes, push-pull 50's in class AB. For speakers I use 1 trumpet speaker and 2 dynamics. One thing I

see very few P.A. men do is to control the volume of the individual speakers. I run the dynamics at medium volume and the trumpet at full volume in order to cover the far side of the grounds and still not blow the ears off of the people close to the dynamics.

When I collect the money from the merchants I give them a souvenir of the event. I find they remember me when I come back the following year. Last year I gave them a picture of the P.A. set-up, this year a small record containing their announcement, as *I have my own recorder.*

This proves that P.A. rentals are still around but it just takes a little work and ingenuity to dig them out. I believe that all P.A. men can still use the extra money from such rentals.

MERRILL LINDLEY,  
Indianapolis, Ind.

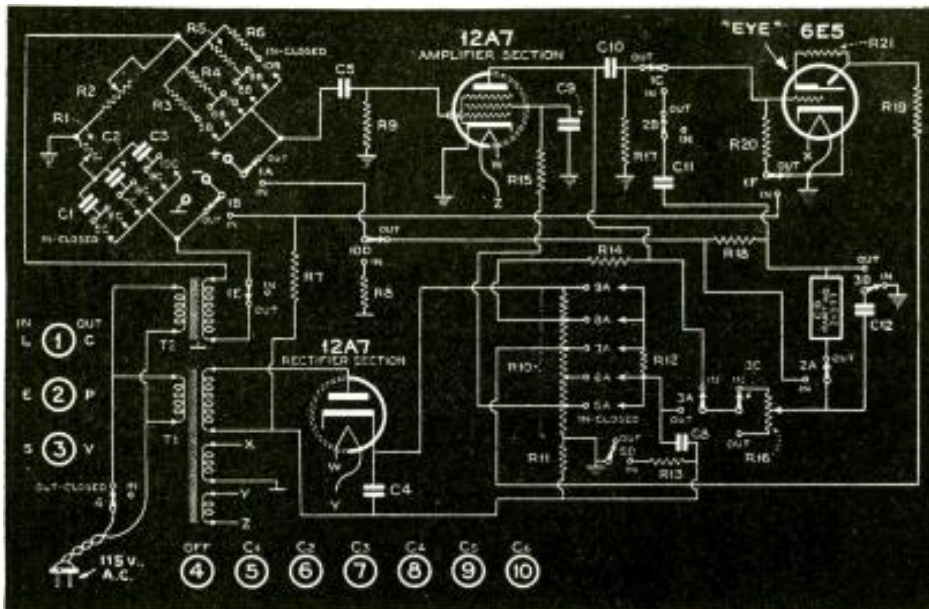

Fig. 1. Schematic diagram of the new Condenser Analyzer.

### DIAGRAM VALUES

- R1—640 ohms, variable
- R2—50,000 ohms, variable
- R3—500 ohms, special
- R4—5,000 ohms, special
- R5—50,000 ohms, special
- R6—0.5 meg., 1/2-watt
- R7—2,000 ohms, 1 watt
- R8—25,000 ohms, 1/2-watt
- R9—2 megs., 1/2-watt
- R10—voltage divider, 45,000 ohms
- R11—1,000 ohms, 1 watt
- R12—15,000 ohms, special
- R13—3,000 ohms, 1/2-watt
- R14—0.5 meg., 1/2-watt
- R15—0.5 meg., 1/2-watt
- R16—50,000 ohms, special
- R17—1 meg., 1/2-watt
- R18—20 megs., 1/2-watt
- R19—25,000 ohms, 1 watt
- R20—10 megs., 1/2-watt
- R21—1 meg., 1/2-watt
- R22—50,000 ohms, 1/2-watt
- C1—2.4 mf., 60 V., A.C.
- C2—0.12 mf., 200 V., D.C.
- C3—0.012 mf., 60 V., A.C.
- C4—8.0 mf., 500 V., D.C.
- C5—0.05 mf., 400 V., D.C.
- C8—8.0 mf., 500 V., D.C.
- C9—0.1 mf., 200 V., D.C.
- C10—0.05 mf., 400 V., D.C.
- C11—0.5 mf., 600 V., D.C.
- C12—0.5 mf., 400 V., D.C.

# NEW CONDENSER ANALYZER — Thrifty Service Tool

"All the functions which permit complete analysis of any condenser from a tiny 10 mmf. mica unit to a 240 mf. electrolytic are performed by this instrument . . ."

LEON L. ADELMAN



Fig. 2

**I**N spite of the extreme care exercised by reputable manufacturers of condensers and refrigerator capacitors, there is no avoiding the fact that condensers will sometimes develop defects. That such defects are very frequently the result of incorrect applications, mistreatment, etc., does not alter this basic fact. What is more, such defects may result in the types of trouble which are most difficult to diagnose in a receiver circuit.

In view of these facts it is unfortunate that instruments capable of checking all characteristics of condensers have been prohibitively expensive. Actually it is this fact that has done much to accentuate condenser defects in the past. Because of the lack of equipment for checking condensers everything else in an obstinately inoperative receiver was likely to be checked first, then the condensers checked by substitution as a last resort. If one of these proved to be defective all the time spent in troubleshooting would be blamed on this condenser whereas with adequate condenser analyzer equipment the defect might have been discovered in the earlier diagnostic procedure.

In the case of resistors the whole story is told by a single check—that of the resistance value. But not so with condensers. Here leakage, power-factor, insulation resistance, shorts, opens, intermittent operation, etc., all represent possible sources of trouble, and a sure-

fire instrument for checking and measuring all of these characteristics as well as for measuring values of capacity has been sorely needed. Such a unit, for complete condenser analysis, is shown in Fig. A.

All of the functions which permit complete analysis of any condenser from a tiny 10 mmf. mica unit to a 240 mf. electrolytic are performed by this instrument, which is here described. It is completely self-contained in its neat carrying case which measures only 6½ x 12 x 9¾ ins., and weighs but 9 pounds, making it entirely practical for either bench or portable applications.

#### PUSHBUTTONS

For those who are interested in studying the circuit of this novel instrument, the complete schematic circuit is shown in Fig. 1. All switching operations are performed by means of pushbuttons and to properly relate the schematic circuit to the control panel photograph these button switches are shown in the same relative position in both. The switches themselves are numbered on the schematic to correspond with their control buttons. That is, all switches marked with the number 1 are operated by button No. 1; and the letters following the numbers represent different sections of this switch by means of which several switching operations are performed simultaneously when the button is depressed.

The buttons are arranged in 2 groups. The left-hand group of 3 sets up the instrument for the type of measurement desired.

Button No. 1 thus provides for

leakage measurements when depressed and capacity measurements when released.

Button No. 2 is depressed if the condenser under test is of the electrolytic type and released for measurements of paper or mica condensers.

Button No. 3 provides a choice of "sharp balance" or "broad balance."

The buttons in the lower bank operate only when depressed. These control the selector switches by means of which the correct capacity range, or the correct test voltages are selected, depending on whether switch No. 1 is set for LEAKAGE or CAPACITY measurements.

This switching arrangement is self-  
(Continued on page 366)



Fig. A. Cornell-Dubilier Model 8F-50 Condenser Analyzer.



# EMISSION VS. MUTUAL CONDUCTANCE TEST

*A meter engineer tells Servicemen why proper tube analyses will help his business; and how these analyses are facilitated by an understanding of the fundamental varieties of tube testers, viz.—mutual conductance (both dynamic and grid-shift), output, and emission types.*

E. T. HIGGONS



Emission tester.

**F**OR some reason it seems apparent that many Servicemen during the past few years have decided not to sell tubes. As a matter of fact, they seem to have come to the conclusion that they cannot

sell anything but service. For just that same reason those Servicemen are losing many dollars of good, clean profit every year. This idea that a Serviceman cannot sell a thing is nothing more than a self-conceived notion. He *can* sell—if he wants to, principally because he is in a better position to sell than the average dealer.

The biggest problem in selling anything is to get a prospect into the store. Millions of dollars are spent throughout the country each year in advertising in an effort to contact new prospects. The Serviceman is extremely fortunate in that he does not have to wait for a prospect to come to see him, he visits with them right in their own homes. The Serviceman does not even need a calling card to contact a possible sale!

## MR. SERVICEMAN:

A surprising lack of activity is shown to exist with respect to tube sales if an analysis of the yearly reports of the tube manufacturers is examined. Those reports indicate that the replacement tube business amounts to about 1½ tubes per receiver. If the average receiver contains 6 tubes that means that the expected life of a tube is about 4 years. This we do not believe possible unless the great American public has ceased to listen to the fine radio programs presented. If such a condition does exist there must be some very definite reason for this. Inadequate tube testing plus disinterest seems responsible for the present situation. A correction of this condition is entirely the responsibility of the Serviceman. He is the most logical person to replace tubes provided he is so inclined and properly equipped.

Many repair jobs go back to customers with weak, inefficient tubes at the risk of a failure within a very short period of time. Eventually the customer takes those tubes to the neighborhood dealer or department store for test and

replacement and the Serviceman misses some profit. Quite often a Serviceman purposely neglects to replace tubes which are definitely known to be weak simply because he wants to keep the bill down. Quite naturally a man does not want a big repair charge if he can at all avoid it, but the chance of complaints on tube charges are remote. A labor charge may be questioned as it is intangible and the average layman does not appreciate some of the difficulties associated with receiver servicing, but an item covering the cost of tubes is not very easily questioned as tubes are actual physical realities having definite value.

## TUBE TESTERS

The greatest reason for low tube sales is undoubtedly inadequate or improper tube testing. A tube tester of some sort must be used if tube sales are expected and that piece of equipment must be just what the name implies. A box containing a meter, sockets and switches is not necessarily a tube tester. Careful attention should be given to the choice of checkers in order to obtain one which will do a good job for a reasonable period of time. It is important when spending from \$30 to \$50 to be assured of the best possible service. A study based on a comparison of costs against accuracy and probable length of service will determine the best selection.

At present there are 3 fundamental varieties of tube testers available, namely mutual conductance, output and emission types. An analysis of each represents all of the material which is needed for a sensible selection of the instrument best suited for the individual requirements.

### Mutual Conductance Tester

The mutual conductance or transconductance tester is perhaps the most accurate, although tests recently show the improvement in accuracy over other types to be about 3%.

**Grid-Shift Test.** This form of test is usually accomplished by what is known as a *grid-shift method* (See Fig. 1), wherein the plate current change is measured for a given change in grid voltage.

**Dynamic Test.** Or in other cases by a dynamic test, by measuring the A.C. component of the plate current with a definite A.C. signal applied to the grid (See Fig. 2).

By definition of mutual conductance this method requires that *all element potentials and plate loads must be held at rated values of operating conditions* if a high degree of accuracy is to be

(Continued on page 374)

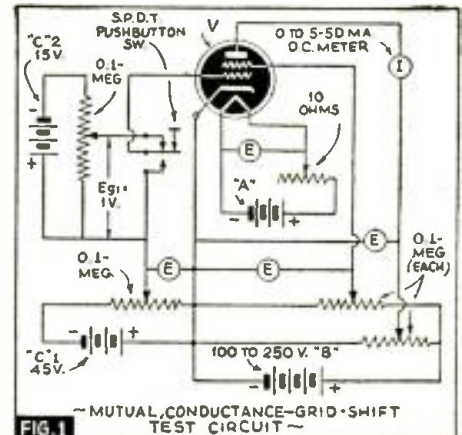

~ MUTUAL CONDUCTANCE-GRID-SHIFT TEST CIRCUIT ~

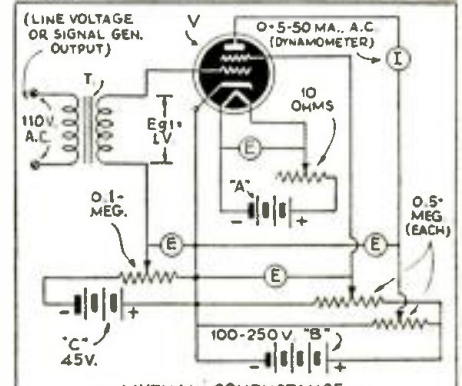

~ MUTUAL CONDUCTANCE-DYNAMIC TEST CIRCUIT ~

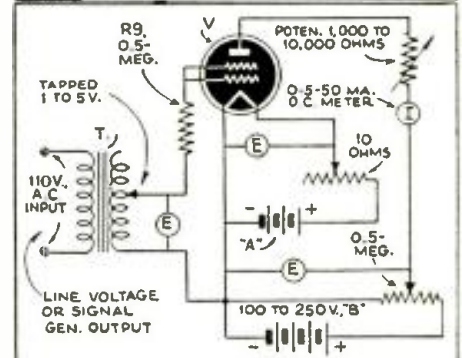

~ OUTPUT-TEST CIRCUIT ~

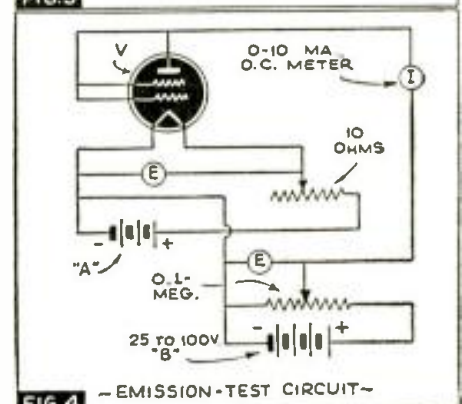

~ EMISSION-TEST CIRCUIT ~

Basic circuit diagrams of the various systems of tube checking discussed.

# FREQUENCY-MODULATED PROGRAMS

## With This Easily-Built F.M.-A.M.

Major Edwin H. Armstrong, Professor of Electrical Engineering, Yankee Network, have put their seal of approval on this initial section not only to acquaint RADIO-CRAFT readers with the principles underlying month but also presents a description of frequency modulation vs. ampli-

### PART I—FREQUENCY VS. AMPLITUDE MODULATION

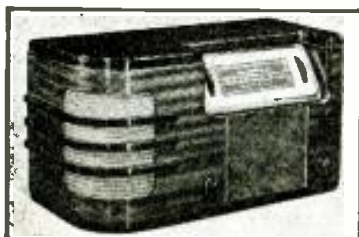

Frequency-modulated receiver.

strip, in scientific importance, all previous developments.

For years the Major worked to perfect methods and means of eliminating or reducing static and other radio interference—probably the foremost problem confronting the radio industry. After trying various methods of attacking the problem, he had practically given up the idea as he and his associates could see no practical answer.

Over 10 years ago he started a new line of attack which eventually led into a system known as the *wide-band* frequency modulation system which reduced all sorts of disturbances to a very small percentage of their original value. This was accomplished by transmitting a signal having such characteristics that it could not be reproduced by either natural or man-made static; and designing a receiver which was not responsive to ordinary types of modulated waves but only responsive to waves having the special characteristic.

Thus this type of transmission and reception emerges from the laboratory and bids fair to revolutionize the transmission of intelligence.

It is the purpose of this article to explain what frequency modulation is, how it operates, and the advantages which it presents as compared to amplitude-modulated systems.

ONE of the pioneers in radio has again scored an outstanding success. Major Armstrong, who will be remembered as the Father of the superheterodyne type of receiver, has again advanced the art by developing a new type of transmission and reception which bids fair to far out-

#### "A.M." AND "F.M."

A concept of *amplitude* modulation (or "A.M.") may be obtained from the diagram of a high-frequency alternating voltage which changes its amplitude with time, as shown in Fig. 1. This is the type of modulated carrier transmitted by present-day methods. Figure 2 shows a carrier frequency, the frequency of which is changing at some definite rate. This is the type of signal which is transmitted by a *frequency-modulated* (or "F.M.") station. Now let us examine tuned circuits and see how amplitude and frequency modulation can actually be effected.

"A.M."—Assume that the tuned circuit shown in Fig. 3 is continually supplied with energy so that the alternating current set up therein has the same amplitude at all times. Let us insert in this tuned circuit a microphone which has the property of varying its resistance according to the amplitude of sound waves impinging on the diaphragm. It is well known that if the resistance of a tuned circuit varies, the amplitude of the current flowing in the tuned circuit varies accordingly. Consequently, sound waves striking the diaphragm of the microphone would cause a current to flow in the tuned circuit such as that shown in Fig. 1.

"F.M."—An idea of the method in which a frequency-modulated signal could be produced may be had from the same tuned circuit and again assuming that energy is being supplied to this tuned circuit so that the amplitude of the current is at all times constant.

Now let us connect across the tuned circuit a condenser type of microphone which consists essentially of 2 thin metallic plates, the positions of which vary in respect to each other in accordance with the sound waves striking the microphone. As this microphone does not change its resistance appreciably, a sound wave impinging on the microphone would simply vary the frequency of the tuned circuit because the total capacity of the tuned circuit would be altered and its frequency is dependent upon the capacity. This circuit is shown in Fig. 4. Sound waves thus may be made to vary the carrier frequency such as shown in Fig. 2.

In the foregoing analysis only theoretical arrangements have been considered both for the amplitude-modulation and frequency-modulation methods. In practice, of course, more complicated arrangements must be employed to effect either type of modulation to give a commercially useful result.

#### STATIC FREE

A simple explanation of why the system is so free from static and other disturbances lies in the fact that these disturbances, while they have very great amplitude-modulation changes have relatively small frequency changes. Hence by designing a receiver for frequency modulation which does not respond to amplitude changes and which only responds well to large frequency changes practical immunity from interference can be obtained.

Then by designing a transmitter which sends out a widely swinging frequency modulated wave a full response can be obtained in the receiver. The differentiation between noise and signal resides mostly in this special characteristic.

Estimates on the effectiveness of elimination of static due to lightning, etc., vary from 96% to about 99%. It is certainly true that frequency modulation signals can be heard right through a local thunderstorm while amplitude modulation

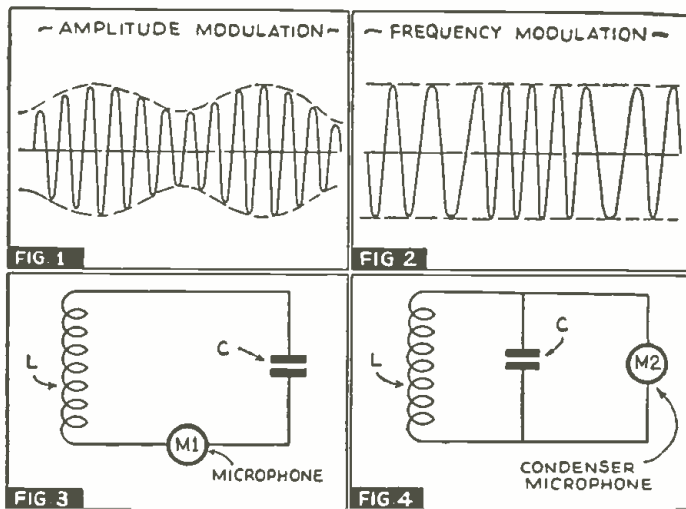

At 1 and 3 are shown, respectively, a representative waveform of an amplitude modulated signal, and the manner in which it may be produced. An equivalent arrangement for frequency modulation is shown at 2 and 4. In 3, microphone M1 varies its resistance according to the amplitude of sound waves; at 4, condenser-type microphone M2 varies in capacity as the sound waves strike the diaphragm.



# ON YOUR PRESENT RECEIVER!

## Ultra-Shortwave Adapter

Columbia University, and Mr. Paul A. deMars, technical director, The of the 2-part article by Messrs. Browning and Gaffney. Part I serves the Ultra-Shortwave F.M.-A.M. Adapter to be described in detail next tude modulation which is both simply explained and technically accurate.

G. H. BROWNING and F. J. GAFFNEY

signals are entirely blotted out due to noise.

### RECEIVER REQUIREMENT

**Limiter.**—As frequency modulation is considerably different from the standpoint of its transmission, it is only natural that the receiver picking up frequency modulation signals is materially different in its design.

Fundamentally, the receiver has an R.F. amplifier system which should pass a broad band of frequency as will be evident from future considerations. It then has a wide-band I.F. amplifier in which is incorporated a "limiter circuit," the function of which is to keep the amplitude of the amplified signal constant at all times. This limiter might be likened to a very rapidly-acting automatic volume control system.

**Detector.**—The detecting system for frequency-modulated signals varies materially from the conventional type. This will be appreciated by careful analysis

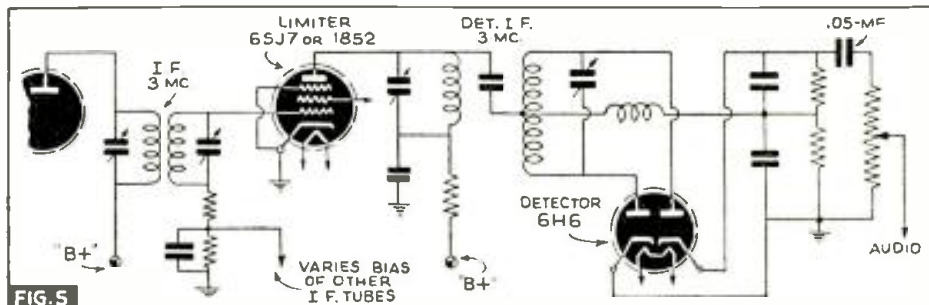

Detailed diagram showing the manner in which the "limiter" is connected to prevent amplitude variations being passed on to the detector circuit.

of the method of transmission. If we go back to Fig. 4 and consider sound waves impinging on the condenser microphone it is readily apparent that the amount the condenser plates of the microphone move is in general proportional to the loudness of the sound waves and consequently the amount of variation of the carrier frequency is proportional to the intensity of the sound waves. The num-

ber of fluctuations per second which the diaphragm executes is obviously the same as the frequency of the audio note impinging on it. This means that the frequency of the carrier will swing back and forth over its range a number of times per second which is the same as the audio frequency being transmitted. Thus the detecting system must be ca-

(Continued on page 378)

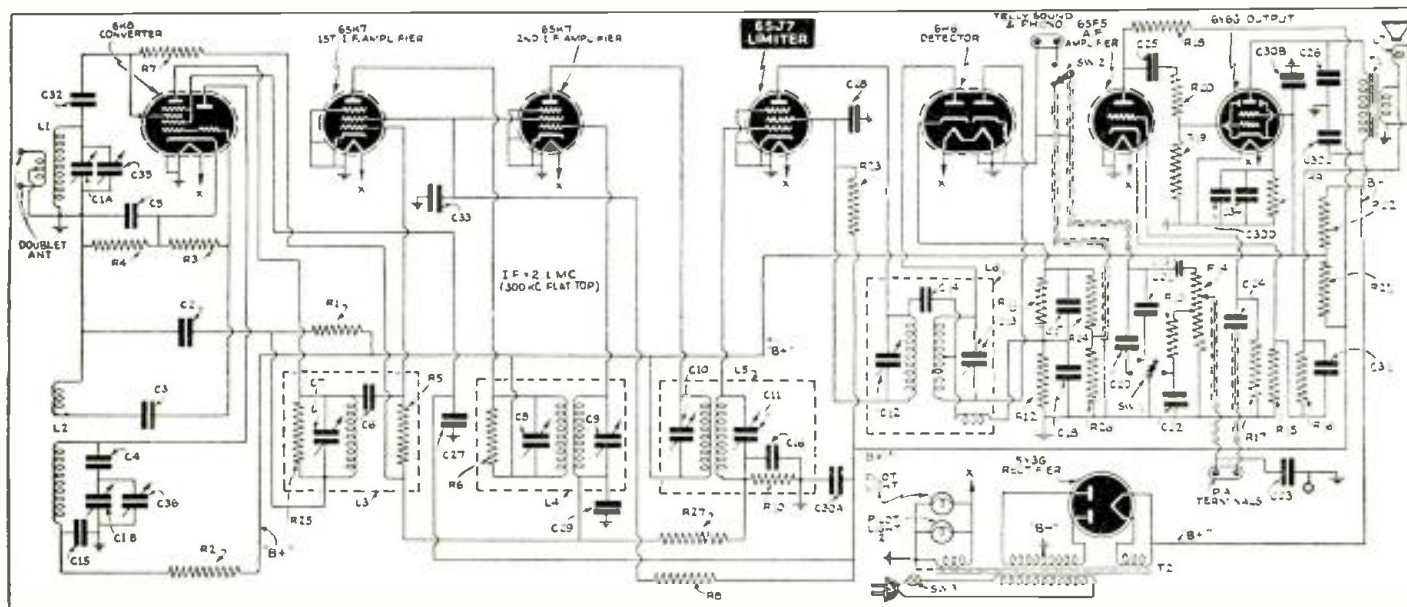

Schematic circuit of the G.E. HM-80 table-model frequency-modulated receiver (see photo, pg. 336). It embodies in a minimum number of tubes the principles discussed by Messrs. Browning and Gaffney; only the larger consoles incorporate a changeover switch to permit amplitude-modulated reception.

- |                        |                        |                        |                         |                         |                         |
|------------------------|------------------------|------------------------|-------------------------|-------------------------|-------------------------|
| <b>CONDENSERS</b>      | C20—0.002-mf., 600 V.* | C30d—20 mf., 25 V.*    | R3—47,000 ohms, 1/2-W." | R15—82 ohms, 1/2-W."    | R26—0.22-meg., 1/2-W."  |
| C1—20 mmf. tuning      | C21—470 mmf.**         | C31—0.1-mf., 300 V.*   | R4—330 ohms, 1/2-W."    | R16—220 ohms, 1/2-W."   | R27—2.2 megs., 1/2-W."  |
| C2—0.02-mf., 400 V.*   | C22—0.002-mf., 600 V.* | C32—470 mmf.**         | R5—0.47-meg., 1/2-W."   | R17—15 megs., 1/2-W."   | *Paper; **mica; †dry    |
| C3—47 mmf.**           | C23—220 mmf.**         | C33—0.1-mf., 400 V.*   | R6—47,000 ohms, 1/2-W." | R18—0.32-meg., 1/2-W."  | electrolytic; †carmin.  |
| C4—1,200 mmf.**        | C24—0.005-mf., 400 V.* | C34—0.05-mf., 200 V.*  | R7—0.47-meg., 1/2-W."   | R19—0.47-meg., 1/2-W."  | <b>MISC.</b>            |
| C5—0.05-mf., 200 V.*   | C25—0.05-mf., 400 V.*  | C35—2.15 mmf. antenna  | R8—4,700 ohms, 1/2-W."  | R20—1,500 ohms, 1/2-W." | SW, 1—Tone switch       |
| C6—500 mmf. trimmer    | C26—0.005-mf., 600 V.* | trimmer                | R9—220 ohms, 2 W."      | R21—2,200 ohms, 1 W."   | SW, 2—Phono switch      |
| C14—47 mmf.**          | C27—0.005-mf., 400 V.* | C36—7.23 mmf. air      | R10—0.33-meg., 1/2-W."  | R22—1,600 ohms, 3/2 W." | SW, 3—Power switch      |
| C15—470 mmf.**         | C28—0.05-mf., 400 V.*  | trimmer                | R11—0.1-meg., 1/2-W."   | W.-W.                   | (on SW, 2)              |
| C16—22 mmf.**          | C29—0.05-mf., 200 V.*  | <b>RESISTORS</b>       | R12—0.1-meg., 1/2-W."   | R23—2,200 ohms, 1/2-W." | L1—Ant.; L2, osc.; L3,  |
| C17—100 mmf.**         | C30a—20 mf., 250 V.*   | R1—2,200 ohms, 1/2-W." | R13—0.12-meg., 1/2-W."  | R24—0.1-meg., 1/2-W."   | 1st I.F.; L4, 2nd I.F.; |
| C18—100 mmf.**         | C30b—20 mf., 250 V.*   | R2—6,800 ohms, 1/2-W." | R14—2-megs., volume     | R25—33,000 ohms, 1/2-   | L5—I.F. limiter; L6—    |
| C19—0.005-mf., 400 V.* | C30c—40 mf., 250 V.*   |                        | control                 | W."                     | discrim. trans.         |

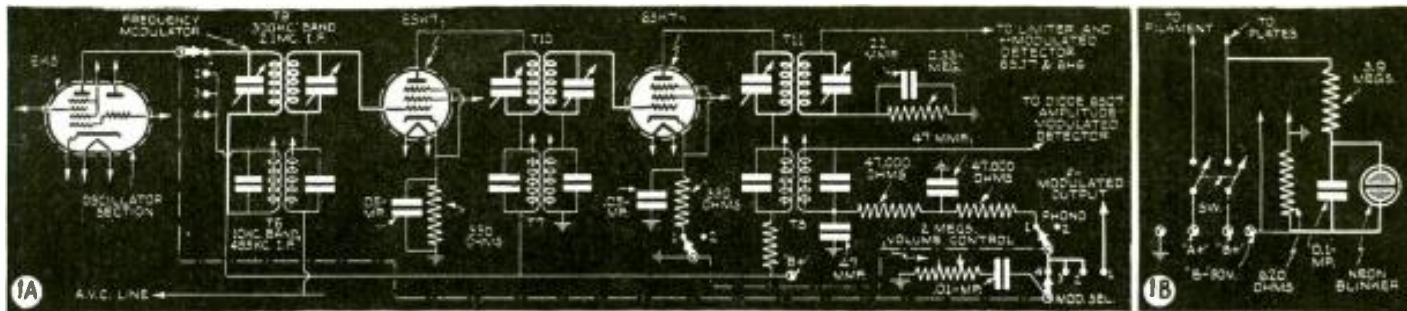

Fig. 1. New circuit features of (A) General Electric Model HM-136; (B) RCA Model BT-42.

# NEW CIRCUITS IN MODERN RADIO RECEIVERS



The details of the modern radio receiver circuits that make them "different" from previous designs are illustrated and described each month by a well-known technician.

F. L. SPRAYBERRY

NUMBER 27

### (1) SET RECEIVES EITHER FREQUENCY- OR AMPLITUDE-MODULATED SIGNALS

General Electric Model HM-136. A very simple ganged switching arrangement permits the use of either of 2 I.F. channels in this receiver, Fig. 1A, although only 1 set of tubes is used in the amplifier.

For frequency-modulated signals, a relatively high-frequency I.F. amplifier is used. Transformers T9, T10 and T11 form this amplifier which amplifies a band of frequencies, approximately 300 kc. wide, centered at 2.1 mc. The output of this amplifier is fed into a limiter to maintain the signal strength constant at this point and then to a detector for frequency-modulated signals. This latter resembles an A.F.C. discriminator in design and operation.

The other I.F. amplifier is designed to pass a 10-kc. band of frequencies centered at 455 kc. It consists of transformers T6, T7 and T8. While the 1st two primaries of the dual I.F. amplifier are supplied separately the other primaries and secondaries, except the output sec-

ondaries, are in series. Their wide difference in frequency accounts for the fact that they have no substantial effect on each other.

At high frequencies the tuning condensers of the low-frequency transformers act as bypass condensers while at low frequencies the choking effect of the high-frequency coils is negligible. An audio switch ganged to the input audio output from the correct detector.

### (2) NEON BLINKER PILOT LIGHT USED

RCA Model BT-42. To avoid the relatively large loss of an ordinary pilot light in a small battery-operated receiver, a neon blinker operated from the "B" supply is used to indicate whether the receiver is turned on or off.

The circuit is shown in Fig. 1B. When the ganged filament and plate supply switch Sw. is thrown to "on", the 0.1-mf. condenser charges slowly through the 3.9-meg. resistor. As soon as the condenser charges up to the ionization voltage of the neon blinker, the latter will

flash and discharge the condenser, and the process will continue in the manner of a sawtooth (relaxation) oscillator. The average current drain from the plate supply is considerably less than 20 microamperes, and a very satisfactory index of the position of the power switch is given by from 2 to 5 flashes per second of the blinker when the switch is on.

The load on the "B" supply is entirely negligible and the filament-type pilot light is eliminated from the circuit.

### (3) SIMPLIFIED SWITCHING TO AUTOMATIC TUNING

Sears, Roebuck Model 7245. By means of one single-pole double-throw switch, the entire R.F., detector and oscillator tuning systems are changed from all-wave to pushbutton tuning.

The pushbutton tuning system is entirely independent of the allwave switching and the main tuning gang. This great simplicity of switching for pushbutton tuning is accomplished through the use of an auxiliary detector tube

(Continued on page 380)

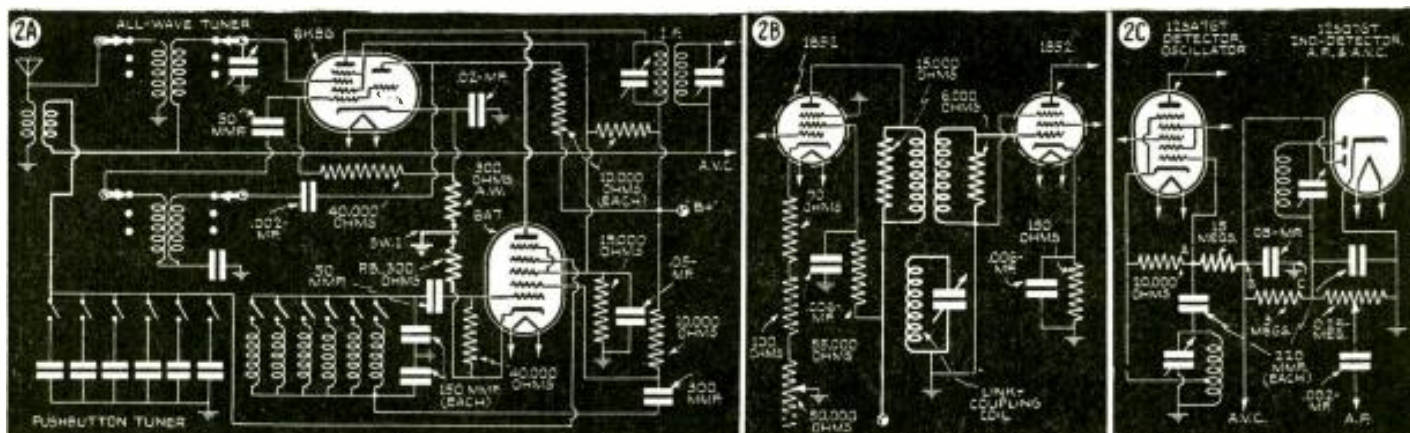
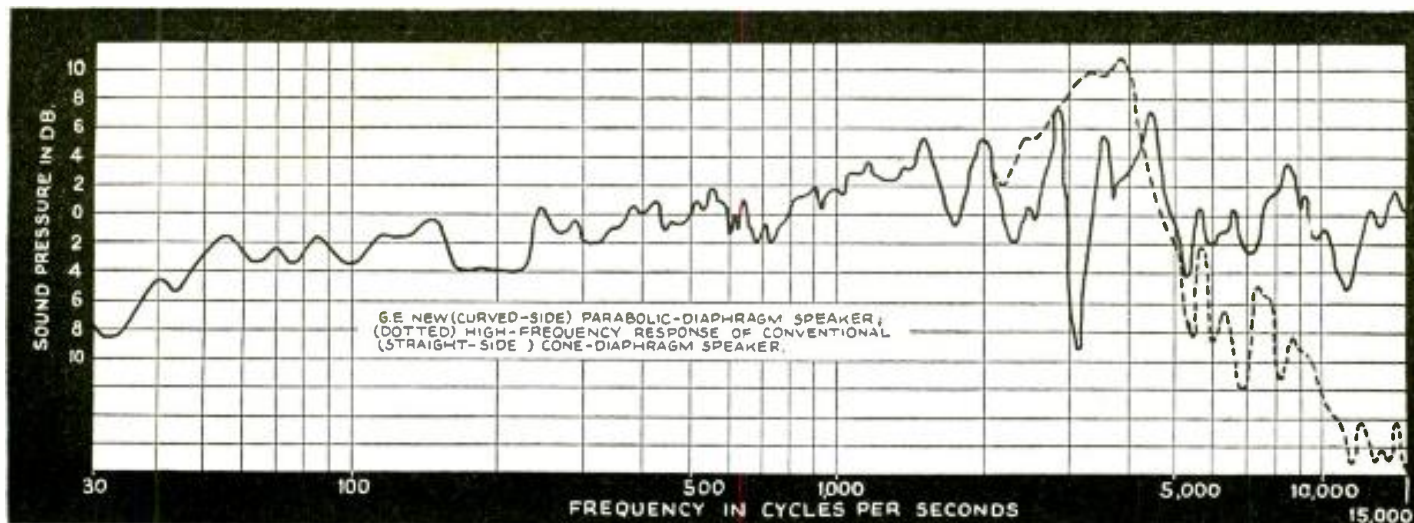

Fig. 2. New circuit features of (A) Sears, Roebuck Model 7245; (B) Andrea Models IF5 and RTE5; (C) Emerson Models DB-296 and DB-301.





Comparative curves. Note the conventional, straight-side (cone) diaphragm speaker's frequency peak near 4,500 cycles, and the drop, to beyond 10 db. below 0 level, at 10,000 cycles; the new, curved-side (parabolic) diaphragm speaker shows excellent response at the limit of the curve (about 15,000 cycles).

# WIDE-RANGE LOUDSPEAKER

*Designed for Reproducing Frequency-Modulated Programs*

*Previous methods of reproducing high-fidelity amplitude-modulated programs, and still-higher-fidelity frequency-modulated programs, involved using 2 loudspeakers. How a single unit now accomplishes the same result makes an interesting story.*

W. S. BACHMAN

**I**N order to realize the improved fidelity that the Armstrong system of frequency modulation makes possible a loudspeaker with extended high-frequency response is necessary. Such an improved loudspeaker is here illustrated and described.

It is well known that the conventional conical direct-radiation type of speaker has a sharp cut-off at approximately 4,500 cycles per second. This cut-off may be explained by the failure of the voice coil to move the diaphragm appreciably above this frequency, because of compliance (or "give"—*Ed.*) at the throat of the cone. In other words, the sharp break at the apex of the cone behaves like a spring. The mass reactance of the diaphragm increases with frequency, and at about 4,500 cycles it becomes great enough to compress this "spring." As the frequency increases the motion of the voice coil is taken up by the "spring" allowing the diaphragm to remain stationary or nearly so.

To reduce the throat compliance a new diaphragm was designed by the General Electric Company, in which the section through an element is approximately that of a parabola. With this shape the diaphragm is tangent to the voice coil collar at the point where they are joined. The elimination of the customary sharp break at this point greatly increases the stiffness of the assembly, and its effect on the high-frequency response may be seen on the sound pressure curve here reproduced.

The edge of the diaphragm is suspended with soft leather which serves the double purpose of giving a low bass resonance and of absorbing wave energy,

at the edge of the diaphragm, which would otherwise be reflected back to cause interference resulting in large peaks and dips in the sound pressure curve. (Comments by the editor follow.)

Known as the G.E. model 1RGS10A, this single wide-range loudspeaker enables the set maker to keep pace with the development of high-fidelity amplitude-modulated transmissions and more particularly the still-higher-fidelity "wide-frequency-response" or Armstrong-type frequency-modulated programs. The frequency-modulated transmitters are said to be capable of delivering to the voice coil of the radio receiver's loudspeaker frequencies up to 18,000 cycles. Ordinary loudspeakers were not capable of reproducing, in a single unit, frequencies much beyond 10,000 cycles, and hence, the need for an entirely new and really high-fidelity loudspeaker design.

This statement, and those which follow, agree with the general ideas expressed in "Frequency Modulation," on pg. 748 of the June, 1939 issue of *Radio-Craft* and at the same time clarify and correct certain expressions contained in this (June-issue) description of new developments in frequency-modulation equipment. (See letter of Mr. Brittain, below.) Although it is true as Major Armstrong stated, on pg. 711, that "a frequency range up to 18,000 cycles has been found desirable, in some music transmissions," response out to this extreme limit is not obtained except with special laboratory apparatus. However, response actually may be realized

(Continued on page 383)

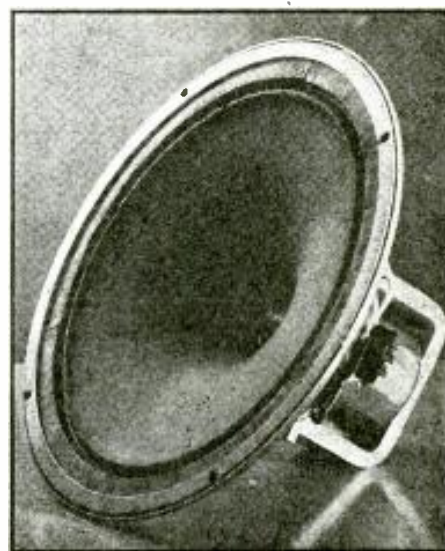

G. E. high-fidelity speaker. Note curved diaphragm.

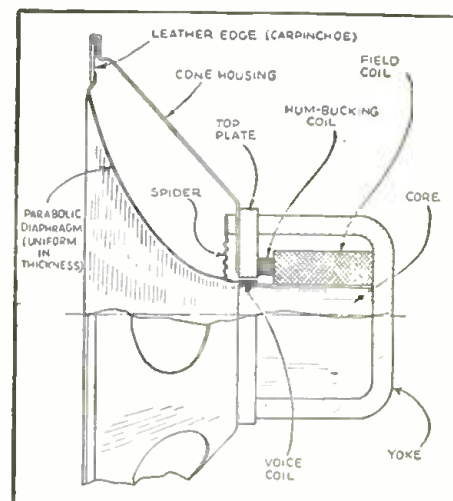

Cross-section, parabolic-diaphragm high-fi speaker.





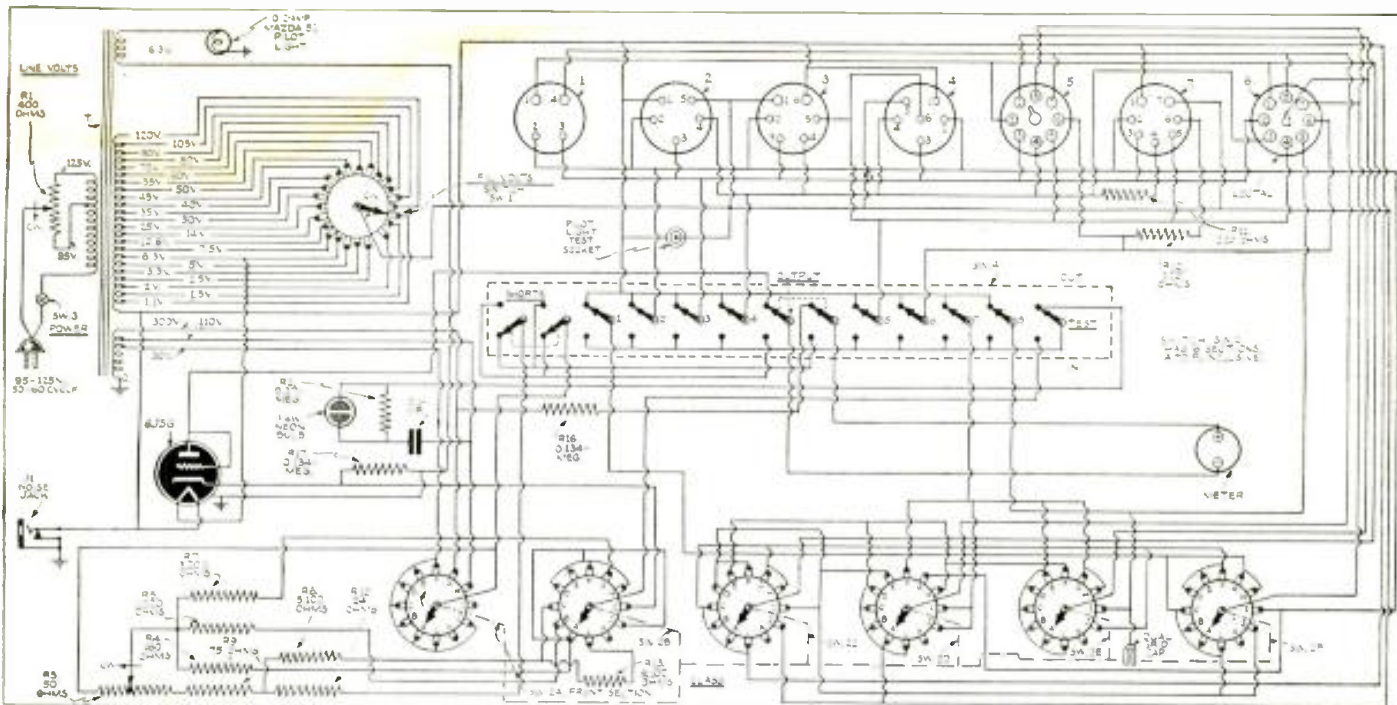

The circuit of the RCA models 156-B and -C tube testers is simple; and effective in testing all the new tubes.

## NEWEST TUBE CHECKER

*Two new tube testers which will check the performance of every standard radio receiving tube type now available, and which have built-in adaptability for new types likely to be introduced in the future, have been announced by the RCA Manufacturing Company.*

**P**ROVISION has been made, in 2 new instruments, for testing octal-base tubes and the new miniature-base tubes, in addition to pilot lamps, Christmas tree bulbs and flashlight bulbs. Each has 2 spare sockets to provide for new types, and additional chart space to insert data on new tubes as they are introduced. Tubes with filament voltages up to 120 volts may be tested.

The testers are operated with one finger, with the buttons released or retained automatically as required for testing. Line voltages up to the instant of the actual tests are shown, making it unnecessary to set the line voltage before inserting the tube in the socket. Four-prong and octal-base ballast tubes may be tested for noisy welds and opens, as may the voltage drop on all types of Gas Tubes. They test Magic Eye tubes for brilliance and the opening and closing of the eye. All tests are made according to R.M.A. standards.

The rugged cases of both models are finished in gray wrinkle lacquer with light metal trim. Both have soft rubber feet, while the portable model has a cover to match, and a special snap-out carrying handle. Total weight is 14 pounds. Exterior measurements are as follows: 13½ x 5¾ x 8 ins. high. Power consumption is 25 W.

An easy-reading roll chart affords ready reference to the active buttons and control settings for each type of tube. Connecting guide lines are marked on the panel from the controls to the corresponding columns of the chart. To insure greater precision, the line voltage is indicated continuously for adjustment except during actual measurement.

### APPLICATION

Practically every standard type of receiving tube as well as special types including the regulator, ballast, tuning indicator (Magic Eye) and certain cathode-ray oscilloscope tubes can be tested for acceptability with this instrument. The standard R.M.A. emission test is applied to all receiving and similar tubes whereas the regulator tubes, which are gaseous in type, are tested for breakdown voltage. Ballast tubes may be checked for open-circuit, and "noisy" welds can be detected readily by means of a pair of phones. In tuning indicators, the visible control range (opening and closing of the "eye") may

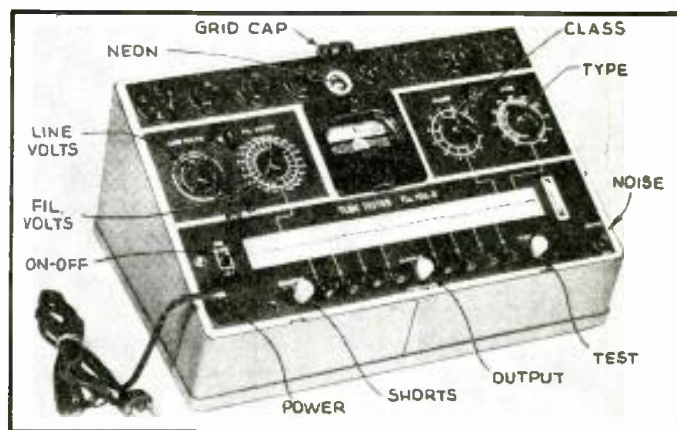

The new RCA models 156-B portable-type tube tester, shown above, and the model 156-C (counter-type), test all the new tubes.

be noted in addition to emission.

Although the emission of a tube normally is an excellent criterion of performance, sometimes it is not the definite limiting factor. Thus, a tube which tests "poor" may, in rare instances, be perfectly satisfactory for a given application, or the reverse may equally well be true.

As noted above, the test procedure will vary with different groups of tubes. Such groups are described separately in the following sections.

**Receiving Tubes.** This group of tubes is by far the largest and embraces the A.C. and battery types of detectors and amplifiers, and the various full- and half-wave rectifiers. The first check is a *short-circuit* test.

In order that Servicemen may see how this and all other tube tests are made, on an instrument of this type, specific procedures are given below. Refer to the diagram for the various controls mentioned.

1. Set the **FIL. VOLTS**, **CLASS**, and **TYPE** controls to the correct settings for the tube under test.

*(Continued on page 371)*

# ALL-PUSH-PULL DIRECT-COUPLED

"Packaged engineering" applied to a basic sound amplifier now enables or more of a large number of important features 90% of which, Mr.

A. C. SHANEY

ANY one or more of the following 6 optional features may be added to the flexible, All-Push-Pull 30-Watt Direct-Coupled Amplifier, originally described in the October, 1939, issue of *Radio-Craft*, with or without the 7 auxiliary features described in the November, 1939, issue of *Radio-Craft*. Lack of space prevents the description of the Non-Frequency Discriminating Scratch Suppressor, which will be covered in a subsequent issue, if readers are interested.

The features to be described in this issue are:

- (1) Remote Control
- (2) Audio Spectrum Control
- (3) Calibrated Volume Indicator
- (4) Push-Pull Automatic Volume Compressor
- (5) Push-Pull Automatic Volume Limiter
- (6) Push-Pull Automatic Volume Control

## REMOTE CONTROL

Remote control circuits have been widely adopted during the past few years for many special applications; particularly in those installations requiring control of volume at some point remote from the amplifier proper. Naturally, the usual grid circuit volume control would be impractical because of

hum pick-up in this high-impedance line. Although low-impedance lines and suitable attenuators may be employed in conventional coupling circuits, this is undesirable because of the increased costs involved, and the difficulty of maintaining flat frequency response with economical matching transformers.

The popular procedure of controlling volume remotely is to employ a pentagrid converter tube (such as the 6L7 or its prototype), and varying the bias of both control-grids. As these tubes were designed primarily for R.F. mixer service, they do not readily lend themselves to audio work because of inherent hum, microphonics, and wide variations in characteristics between similar tubes of the same type.

The conventional remote control circuit furthermore employs a single-sided stage which, in itself, introduces an appreciable amount of distortion. Naturally, the practical solution to this problem is to utilize a push-pull circuit employing tubes of a relatively non-microphonic nature, low inherent hum, and of comparatively stable characteristics.

Figure 1A. The 6SK7 lends itself admirably to this type of application. Figure 1A shows the conventional manner of using a 6SK7 with a series dropping screen-grid resistor. This type of circuit provides a number of interesting and valuable secondary features, such as the change in both screen-grid and plate voltage corresponding to their respective plate and screen-grid currents, which in turn, are controlled by the control-grid voltage.

For remote control purposes, it is important to design the circuit, so that minimum distortion takes place, regardless of the transconductance of the tube. By introducing a variable voltage at the point X, the transconductance of the tube may be changed from 2,000 to 10 micromhos. To further increase the controlling range of the variable voltage, the screen-grid should be disconnected from the cathode and connected to the low end of the grid-return resistor. This, in effect, provides twin-grid control of the electron stream.

If the cathode resistor R1 is made large enough to obtain a bias of -35 volts, the tube will be operating at minimum gain. If the ground end of the grid-return resistor is slowly varied across the cathode resistor R1, the bias

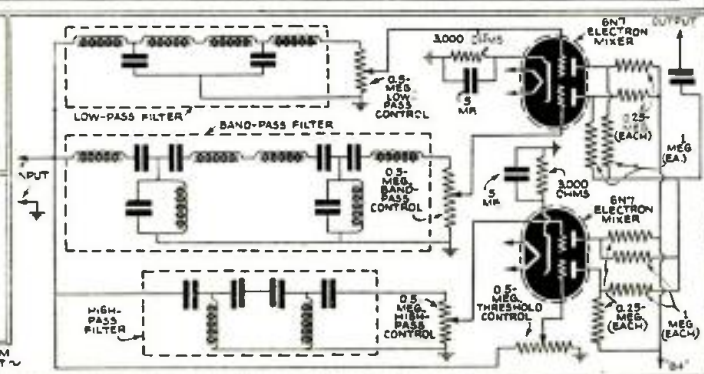
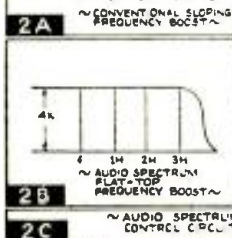
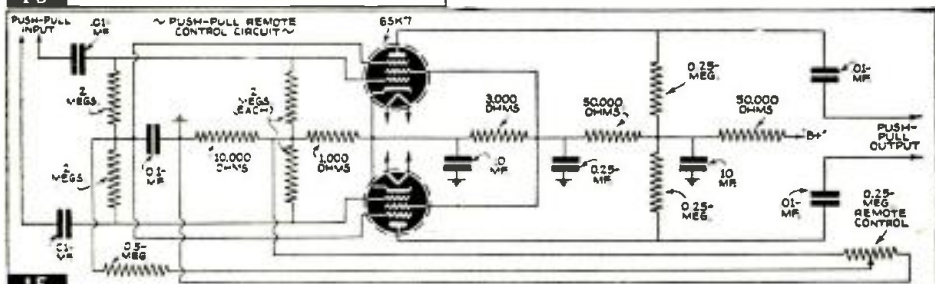
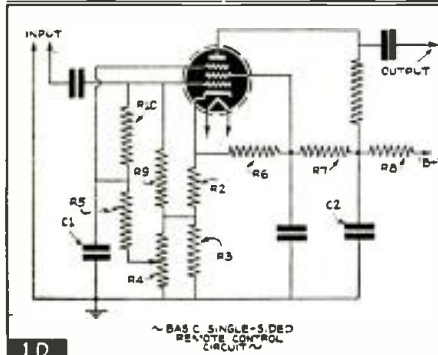
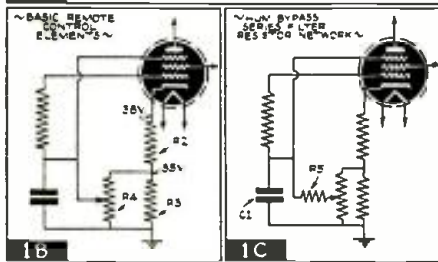
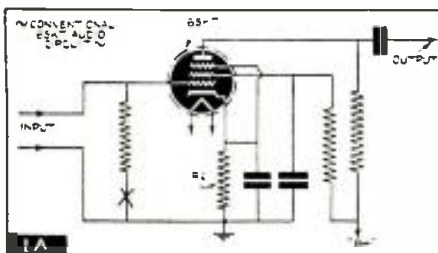



# Modern Features to the

# 30-WATT P. A. AMPLIFIER

any public-address specialist to incorporate in a suitable amplifier one Shaney believes, have never before appeared in any radio magazine!

## PART III

will be decreased, and its gain increased. A limiting resistor should, of course, be inserted at the high end of the cathode, so as to avoid bringing the bias to below -3 volts, as this would bring the tube off its recommended grid-voltage plate-current curves.

**Figure 1B.** This figure shows a revised cathode and grid control circuit to obtain the desired effect. It will be noted that the cathode is 38 volts off ground, while the low end of the limiting resistor R2 is 35 volts from ground. The difference between the two is the effective grid voltage applied to both the control grid and suppressor grid at maximum gain.

**Figure 1C.** When the center arm of R4 is brought towards ground, the bias is gradually increased, until cut-off is approached. If R4 was placed at some remote point, the bias (and gain) of the tube could easily be controlled remotely.

In order to by-pass hum voltages picked up within the three-wire cable, a series filter resistor network should be employed (R5, C1), as illustrated in Fig. 1C. The time constant of this combination should be of such a nature, so as to effectively bypass 60 cycles.

**Figure 1D.** In order to avoid excess distortion, the plate and screen-grid voltages should automatically adjust themselves to different control-grid biases. This is affected by obtaining both of these voltages through a common series dropping resistor (R8), as illustrated in Fig. 1D.

It can readily be seen that the voltage at the junction of R6 and R7 as well as the junction of R7 and R8 will be a function of the drop in R8. The condenser, C2, removes the audio component from this D.C. voltage and provides the optimum plate supply voltage, which, in turn, likewise controls an optimum screen-grid supply voltage.

In order to provide a smooth-acting control, an additional resistor, R9, is added. With resistor R10, this provides a bridged-type control circuit.

**Figure 1E.** The circuit of Fig. 1D may be adopted where single-sided operation is desired. Fig. 1E, however, shows the push-pull derivation of our basic remote volume control circuit.

As the resistor, R4, is across a comparatively low voltage, and as very little current flows through the remote control, its lines may be extended indefinitely. It is unnecessary to shield these cables, regardless of their length, because of the hum filtering circuit employed.

## AUDIO SPECTRUM CONTROL

The theory and operation of the Audio Spectrum Control was completely described in the December, 1937, issue of *Radio-Craft* (page 346), and in the June, 1938, issue (page 797).

Many music lovers utilizing amplifiers having both bass boost and cut control, have invariably complained of the production of "false bass" when boosting low frequencies. An analysis of this condition has disclosed the fact that the

usual form of low boost controls *does not raise the fundamental frequency and all associated harmonics equally.*

**Figure 2A.** The reason for this condition is illustrated in Fig. 2A. Sloping line YZ typifies the usual bass boost response circuit. If F is some predetermined frequency, and 1H, 2H, and 3H, are its 1st, 2nd, and 3rd harmonics, respectively, it will be noted that the fundamental frequency is accentuated approximately 4 times as much as its 3rd harmonic, twice as much as its 2nd harmonic, and 1 1/3 times as much as its 1st harmonic. This change in the relative value of associated harmonics produces a decided change in the character of the fundamental tone.

As is well known, all middle A's in the standard pitch have the same fundamental (Continued on page 364)

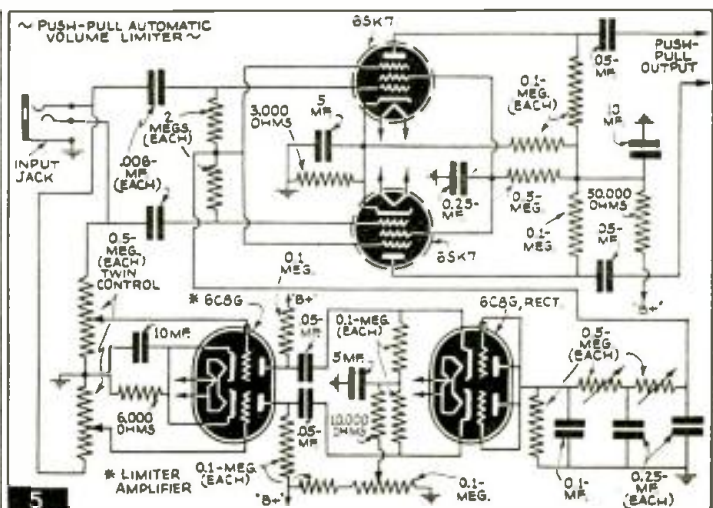
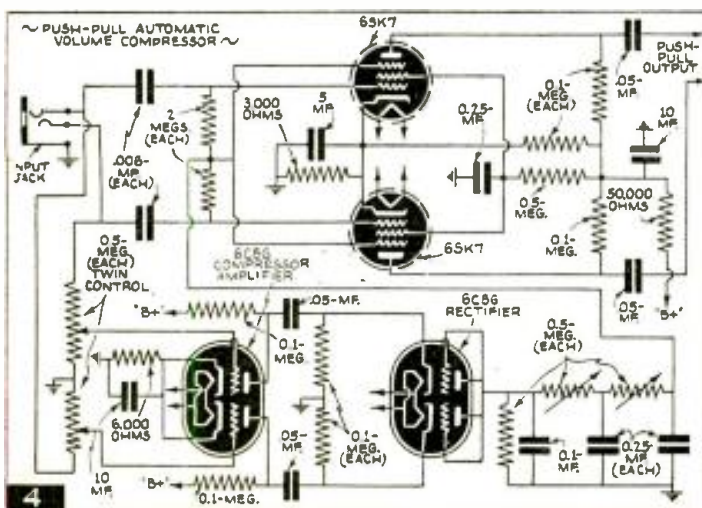
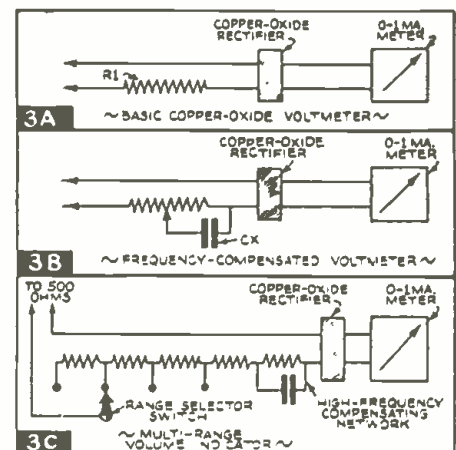





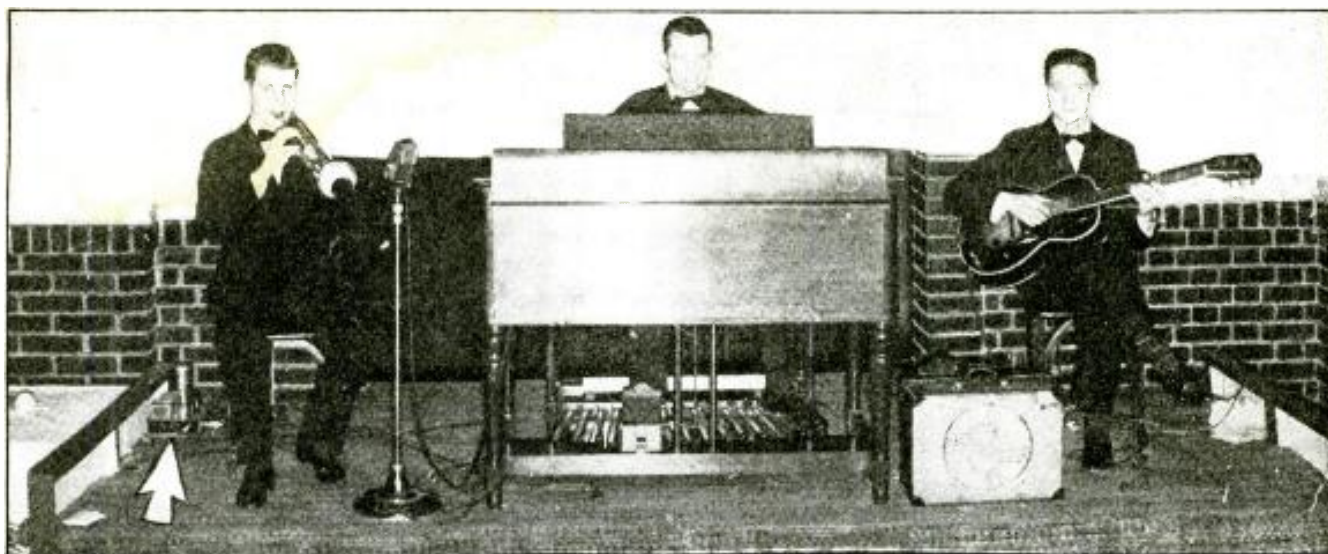

Three-man orchestra—but *electronic*; and that makes all the difference in the world. The entire electrical installation was made by the author, a Serviceman working for a local radio dealer and service organization. Arrow at left indicates the mixer-preamplifier; at right, guitar amplifier and loudspeaker.

## LOCAL SERVICE SHOP CAPITALIZES ON ELECTRONIC ORCHESTRA

*Money can be made in the electronic music field as pointed out many times by RADIO-CRAFT. Mr. S. Leibowitz, working for Olson Bros. Radio Supply, describes in the following letter a sound installation which he made to establish a successful 3-man electronic orchestra.*

*Dear Sirs:*

In the March and April issues of *Radio-Craft* you described electronic organs and made predictions as to their relationship to radio Servicemen and Sound men. Under separate cover I am sending you a photograph (reproduced above—*Editor*) of an installation we made which is a truism to your prediction.

Shown in this photo is a truly radio orchestra furnishing high-class musical entertainment by radio but with the benefit of live musicians. This musical combination is being featured in a well-known Akron, Ohio, night club and functions completely around the new Hammond Electrical Organ. Supplementing the organ are a trumpet player and electrical guitarist. Together they offer musical fullness and brilliance comparable to a 10-piece band.

This combination is enjoying remarkable success and is an outstanding attraction to local night life. A daily broadcast from this ballroom further emphasizes the remarkable musical quality of this truly Radio Orchestra.

This musical combination presides on the regular bandstand with the handsomely finished organ loudspeakers placed in a proper sound distribution point in the ballroom. The electrical guitar, and the microphone carrying the trumpet, are fed into a special mixer (including a preamplifier—*Editor*), designed by the writer, which in turn feeds a 200-ohm input in the organ pre-amplifier. (The special mixer-preampli-

fier can be seen in photo in lower-left corner.—*Editor*)

In the photo can also be seen a conventional guitar amplifier which functions simultaneously with the organ amplifier. That is, the guitar strumming comes out of the organ loudspeakers and guitar amplifier at the same time. It is interesting to note that this arrangement, which was not originally installed, was quite necessary for the proper cooperation of the 3 musicians. Inasmuch as the organ loudspeakers are a considerable distance from the band-

stand the time interval for the sound to travel to the players' ears interfered greatly with their coordination. The guitarist could hear only the sound from the speakers which hindered his timing with the trumpet. The installation of the guitar amplifier not only completely corrected this trouble but made the guitar more prominent than before. It was a fact that in that particular room the guitar feeding into the organ amplifier tended to blend its low register with the organ. The special  
(Continued on page 365)

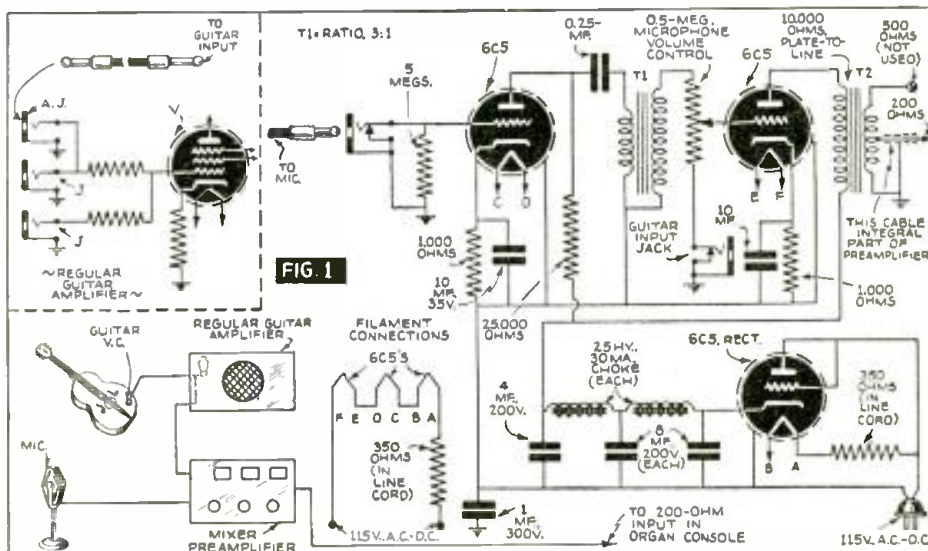

Schematic diagram of the mixer-preamplifier built by the author and designed to work into the input of the organ preamplifier in order to drive the organ to its full output. The block diagram shows the arrangement of the microphone and the electric guitar with respect to their associated equipment.

## STROMBERG-CARLSON SERIES 410 AND 411

(Models 410H, -HB, -J, -JB, -T and -TB; and 411PF, -PFB, -PT and -PTB.)

5-Tube Superhet.; 2 Bands (540 to 1,700 kc. and 5,800 to 18,000 kc.); Electric Tuning; Automatic Volume Control; Phono Input; A.C. Operation Only.

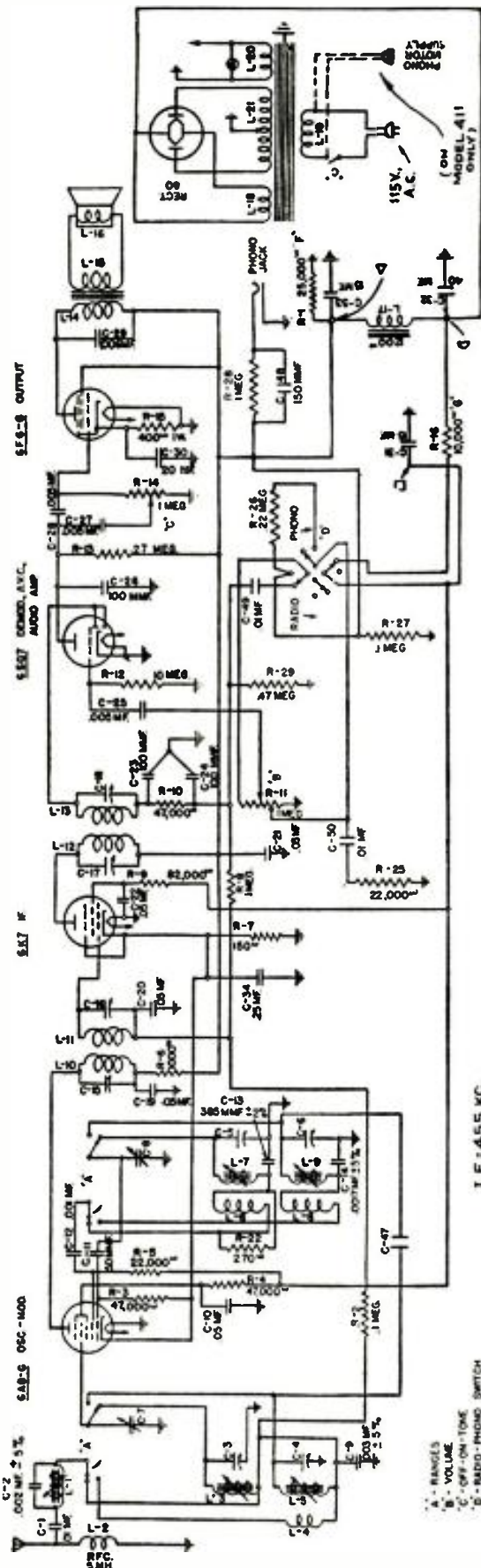

Schematic diagram of the 411 series. The 410 series is similar in circuit except for the phono input circuit which is shown elsewhere on the page.

### ALIGNING INFORMATION

Use a good modulated signal generator (test oscillator) with variable output voltage and a sensitive output meter across the voice coil of the speaker. Always align using the smallest possible input from the signal generator (except when wavetrapping adjustment is made). A strong signal makes adjustments inaccurate. Always have receiver volume control full-on. Never align with tone control in "Bass" position. See diagram for location of all the aligning adjustment screws.

### Aligning Procedure (follow this order exactly)

I. Dial pointer adjustment. With the plates of the gang tuning condenser fully engaged, set the dial pointer directly on the vertical line located at the extreme low-frequency end of the shortwave band.

II. Intermediate-frequency adjustments. (1) Set the range switch to Standard Broadcast position. (2) Tune set to extreme low-frequency end of the dial. (3) Connect the ground terminal of the signal generator to the ground terminal of the chassis. (4) Introduce a modulated signal of 455 kc. to the control-grid cap of the 6AR6 tube, using a 0.1-mf. condenser in series with the output lead of the signal generator. (Do not remove the control-grid clip from this tube.) (5) Adjust the I.F. aligners for maximum output in the following order:  
 (A) Secondary of 2nd I.F. transformer. (B) Primary of 2nd I.F. transformer. (C) Secondary of 1st I.F. transformer. (D) Primary of 1st I.F. transformer.

III. Radio-frequency adjustments. **Short-Wave Range (C Band)**  
 (1) Replace the 0.1-mf. condenser in series with the output lead of the signal generator with a 400-ohm, carbon-type resistor, and connect it to the antenna terminal of the chassis. (2) Set the range switch to the shortwave range (C Band). (3) Set the signal generator frequency and the receiver tuning dial to 6 mc. (4) Adjust the 6-mc. oscillator and antenna (iron cores) for maximum signal. (5) Set the signal generator frequency and the receiver tuning dial to 17 mc. (6) Adjust the 17-mc. oscillator and antenna aligning condensers for maximum signal. (7) Repeat operations 3 to 6, incl.

**Standard Broadcast Range (A Band)**  
 (1) Replace the 400-ohm carbon type resistor in series with the output lead from the signal generator with a 200 mmf. condenser. (2) Set the range switch to the Standard Broadcast Range (A Band). (3) Set the signal generator frequency and the receiver tuning dial to 600 kc. (4) Adjust the 600 kc. oscillator and antenna (iron cores) for maximum signal. (5) Set the signal generator frequency and the receiver tuning dial to 1,500 kc. (6) Adjust the 1,500 kc. oscillator and antenna aligning condensers for maximum signal. (7) Repeat operations 3 to 6, incl.

IV. Wave Trap Adjustment. Leave the receiver connected in the same manner as when adjusting the Standard Broadcast Range ["A" Band].  
 (1) Tune set to 1,000 kc. (2) Set the signal generator frequency to 455 kc. and introduce a fairly strong modulated signal to the receiver. (3) Adjust the wavetrapping aligner for minimum signal.

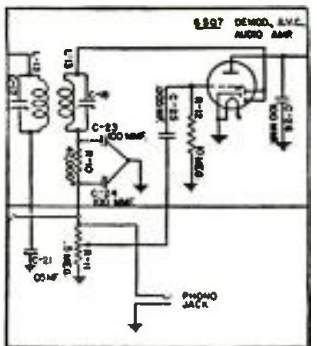

The detail of the schematic of the 410 series showing the difference in the phono input circuit. Compare this diagram with the main schematic to the left.



Stromberg-Carlson model 410H table model receiver.

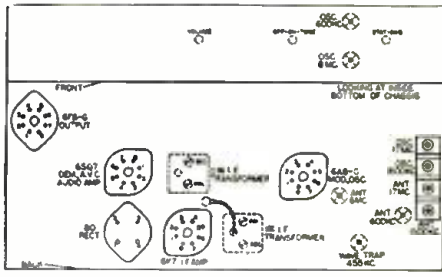

Sketch showing locations of the various components and trimmers. The tube terminal numbering corresponds with that on the voltage table.

### NORMAL VOLTAGE READINGS

Tube	Terminals of Sockets							Heater Voltages	
	1	2	3	4	5	6	7	8	Numbers A.C.
6AR5	0	0	0	-260	-100	+180	6.5	+3*	2-7 6.5
6K7	0	0	0	-260	+100	+270	6.5	+3*	2-7 6.5
6SQ7	0	0	0	0	0	+100	6.5	0	7-8 6.5
6P64	0	0	0	-110	-260	0	6.5	+1.5	2-7 6.5
89	-330	315	315	+330	0	0	0	0	1-4 5

\*Read on lowest possible scale of voltmeter.



RCA VICTOR MODEL K-80 (CHASSIS NO. RC-415-A)

8-Tube Superhet.; 3 Bands (540 to 1,720 kc., 2.3 to 7 mc. and 7 to 22 mc.); Automatic Pushbutton Tuning; Automatic Volume Control; Tone Compensation; A.C. Operation; Tuning Eye; Power Output 5.5W, Max. Underwriters approved.

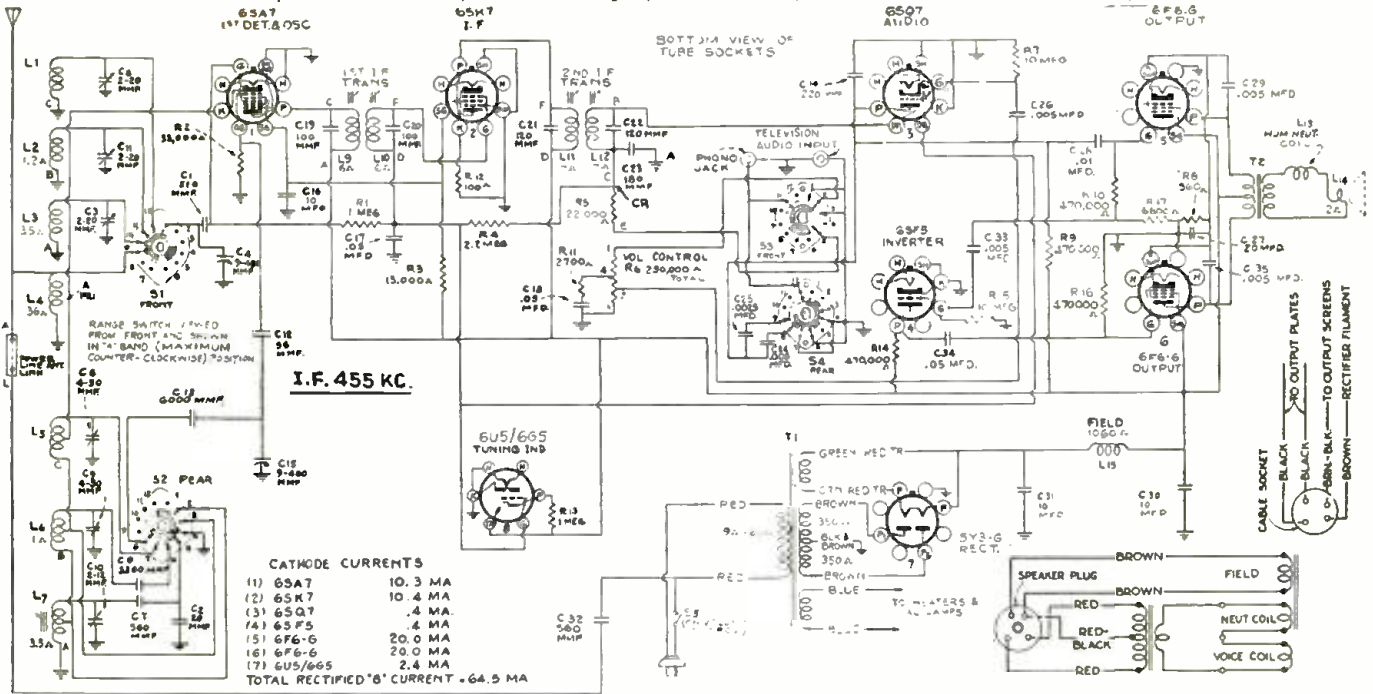

Alignment Procedure

**Cathode-Ray Alignment** is the preferable method. Connections for the oscilloscope are shown in the schematic diagram. Connect vertical "III" to point marked C-D. Connect vertical "0" to chassis.

**Output Meter Alignment.**—If this method is used, connect the meter across the voice coil, and turn the receiver volume control to maximum.

**Test-Oscillator.**—For all alignment operations, connect the low side of the test-oscillator to the receiver chassis, and keep the output as low as possible to avoid A.V.C. action.

**Calibration Scale on Indicator-Drive-Cord Drum.**—The tuning dial is fastened in the cabinet and cannot be used for reference during alignment; therefore, a calibration scale is attached to the tuning drum. The setting of the gang condenser is read on this scale, which is calibrated in degrees. The correct setting of the gang in degrees, for each alignment frequency, is given in the alignment table.

As the first step in R.F. alignment, check the position of the drum. The 180° mark on the drum scale must be vertical and directly under the center of the shaft of the tuning drum when the plates are fully meshed. The drum is held to the shaft by means of 2 set-screws, which must be tightened securely when the drum is in the correct position.

On the inner side of the tuning drum are 2 projections which serve as stops to prevent extreme rotation of the gang condenser. The tuning drum should be set so that the stop limiting clockwise movement of the drum takes effect just as the gang condenser plates are becoming fully meshed, thus preventing stress on the gang due to extreme rotation.

**Pointer for Calibration Scale.**—Improvise a pointer for the calibration scale by fastening a piece of wire to the chassis, and bend the wire so that it points to the 0° mark on the calibration scale when the plates are fully meshed.

Steps	Connect the high side of the test-osc. to—	Tune test osc. to—	Turn radio dial to—	Adjust the following for maximum peak output
1	6SK7 grid in series with .01-mf.	455 kc.	"A" Band Quiet Point between 550-750 kc.	L11 and L12 (2nd I.F. Trans.)
2	6SA7 grid in series with .01-mf.	20 mc.	"C" Band	L9 and L10 (1st I.F. Trans.)
3	Ant. terminal in series with 300 ohms	6 mc.	6 mc. (187.5°)	C6 (osc.)
4		1,500 kc.	"B" Band	C5 (ant.)
5	Ant. terminal in series with 200 mmf.	600 kc.	1,500 kc. (198.25°)	C9 (osc.)
6			"A" Band	C11 (ant.)
7	Repeat step 5.		600 kc. (39.75°)	C10 (osc.)
			"A" Band	C13 (ant.)
				L7 (osc.) Rock Gang

CONNECTIONS & COLORS OF SPEAKER & CABLE

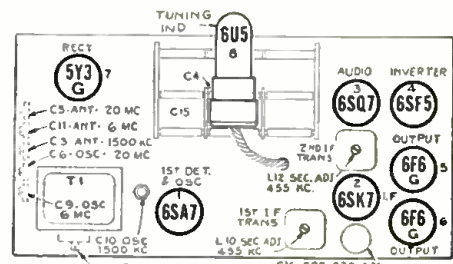

Location of components and trimmers.

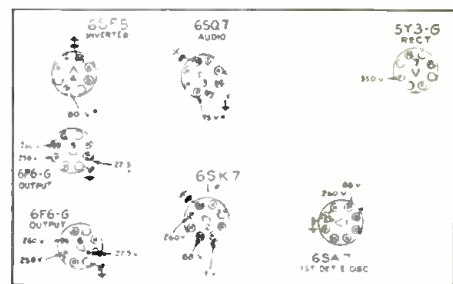

Socket voltages.

Use minimum capacity peak if two can be obtained. Check to determine that 6 has been adjusted to correct peak by tuning receiver to approximately 19.09 mc. where a weaker signal should be received.

Use minimum capacity peak if two can be obtained. Check to determine that C10 has been adjusted to correct peak by tuning receiver to approximately 5.09 mc. where a weaker signal should be received.

Changes

Note: On some receivers the following circuit modifications are in effect:

1. R11 is 5,000 ohms, and T18 is 0.1-mf.
2. C1 is 470 n.m.f.; R15 is 2,700 ohms and is connected from cathode of 6SF5 inverter to ground; R17 is 15,000 ohms; and C23 is omitted.
3. There are 3 types of 2nd R.F. transformers in use.
  - a. The 1st type (Stock No. 14308) has C23 and R5 mounted inside the case, and is connected exactly as shown above.
  - b. In the 2nd type R5 is omitted and the lead from S4 connects to C instead of E. E is not used.
  - c. In the 3rd type R5 is omitted and C23 is connected externally from C to ground. E is not used. The lead from the diode plate connects to A instead of B. When replacing this transformer with Stock No. 14308, remove the external C23 and connect the replacement transformer as shown in the above diagram.



RCA Victor model K-80 console.

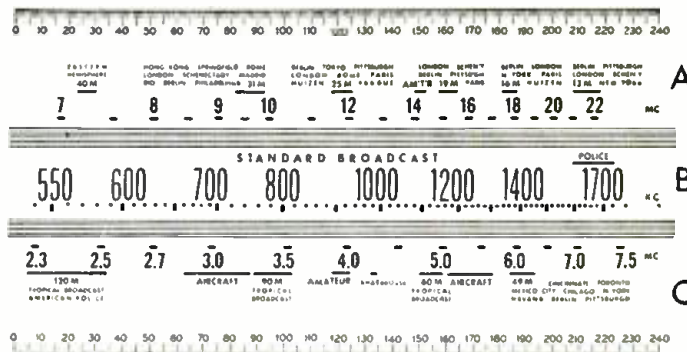

Receiver dial scales and corresponding 0-240 degree calibration scale. The dial indicator for any setting of the calibration scale is determined by drawing a line from this point on the bottom calibration scale to the same point on the top calibration scale.

# NOVEL P.A. INSTALLATION

The customer advertised for an old "auto-call" system but when Mr. Troop got novel and ingenious one at that. Mr. Troop won 1st Prize in the Third

HOBART W.

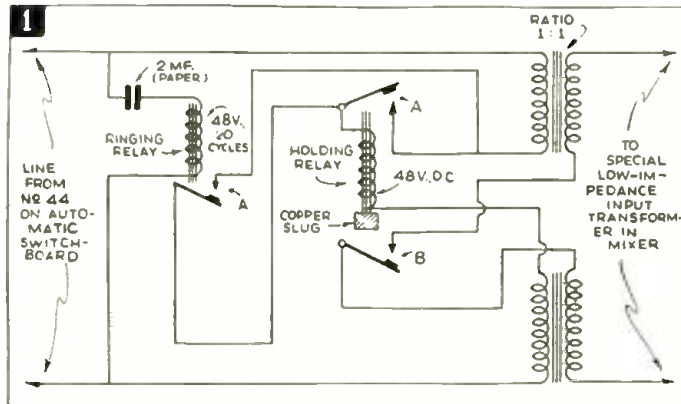

Some of the relays of the telephone switchboard which the author utilized for the P.A. system.

LAST February there appeared in a Boston paper an advertisement for a used "auto-call" system. I replied to that ad by letter, and I stated that such a system was obsolete, and that if they were interested in a modern system I would be pleased to call. The result was that a couple of weeks later I sat in the superintendent's office of a 5-story factory which manufactures leathers and auto accessories.

## TECHNICIAN-SALESMAN

Explaining various P.A. systems, both 1- and 2-way, the 2-way was ruled out on account of noise throughout the factory. In one room alone there are over 100 stitching machines which are going full speed most of the time. Noticing the private automatic dial phone on his desk, I suggested using the telephone system in conjunction with the amplifier, as the telephones were ideal for use in a noisy room. That is, the telephone transmitters were to be used as microphones.

The superintendent wanted to know if I could also put in a set of bells for work signals, so I decided to sell him the idea of an oscillator to work into the amplifier instead of bells, as this would be another selling point for the amplifier. To make the sale more appealing I suggested tying the oscillator to a clock for automatic ringing. They had a time clock which had been in use since 1923 and was hand-wound, spring-operated. I also suggested electrifying the clock, with a Telechron motor, at the same time that I installed the ringing contacts for the work signals. The next suggestion was to tie-in a radio or phonograph for employees' use during dinner hour.

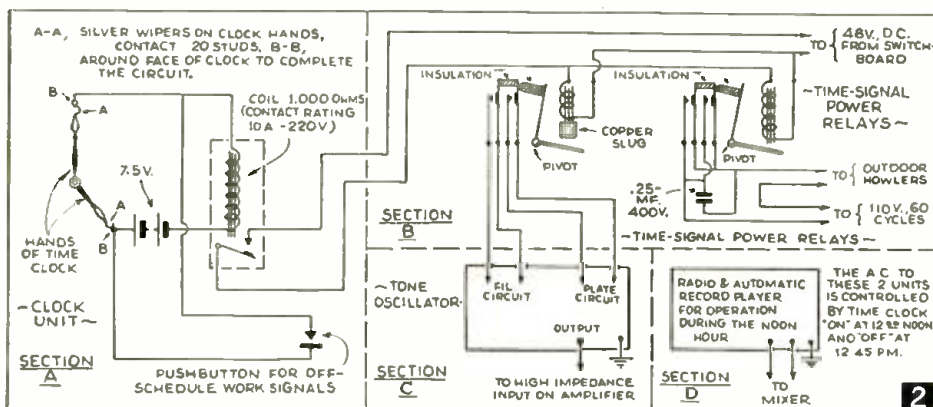

The clock unit tone oscillator and time signal power relays used in this ingenious P.A. installation.

Eventually I installed a pushbutton-operated radio and automatic record changer. The next suggestion was to have the clock automatically turn on and off all these units as well as the switchboard power supply. I explained that the system as outlined was so flexible that it could be extended in various ways at any time in the future. This appealed so much to the superintendent that the contract was signed then and there.

## PURPOSE OF INSTALLATION

The purpose of this installation was to provide a paging system which, in conjunction with the 100-line private automatic dial exchange, would make it virtually a 2-way job; but which also would provide for private conversation if needed.

Example No. 1:—if the elevator, a stitching machine, or any other apparatus is out-of-order, the operator of that machine can dial 44 on any telephone and by speaking into the telephone transmitter direct the proper maintenance man directly to the trouble.

Example No. 2:—if the "super." is on the 5th floor and he wants the foreman of the leather-cutting room which is on the 1st floor, and also Frank Smith who operates a stitching machine on the 4th floor, to meet him in his office he picks up the nearest phone, dials 44 and gives the orders which then can be heard in every part of the factory. Or he might dial 44 from phone number 17 and say, "Tom Jones—call 17." He hangs up, and Tom Jones calls him back at phone No. 17 from wherever he may be.

## TECHNICAL PROBLEMS

The mechanical problems involved in this installation were numerous, and the following description of these problems and their solution in numerical order, the writer feels sure will be of interest.

(1) The first problem was easy—to pick out an unused line on the automatic switchboard. Number 44 was selected as an easy number to remember.

(2) The next job was to pick out the proper pair and trace it through the various frames, relays, and line-finders. I had no previous experience with these automatic switchboards.

The line-finders were in a vertical bank 100 positions high; 2 relays on each level (position), one was a combination A.C. and D.C. type with split armature to each position and 40 blades (i.e., 10 D.P.S.T. switches). Each of these 10 switches operated its own line switch (each of which had 8 relays) and which in turn cut-in a 48-volt, 20-cycle ringing circuit to the called line, operated the "busy," tripped the "completed" or "busy" call counting device, prevented cross-talk, operated trouble lights and relays and, finally, restored all equipment to normal after completion of the call. At the switchboard, I set up a spare phone and dialed various combinations, watching what happened until I had an idea how it worked.

(3) The power supply for the switchboard delivered 48 volts D.C., for talking circuits and 48 volts at 20 cycles for the ringing and some of the relay circuits.

The next problem was to make a relay that would operate on the ringing voltage, as when the code number was dialed, the ringing impulse would have to close the circuit between the phone



# WINS 1st PRIZE IN CONTEST

through talking, he had a completely automatic modern P.A. system—and a highly Section of our P.A. Contest as announced in the November, 1939, issue.

## TROOP

voice circuit and the input of the amplifier, hold-in as long as the caller kept the receiver off the hook, and let go (release) when the caller hung up the receiver. This went fine until the receiver was hung up after calling 44 and the relay did NOT release but stayed pulled-in, so that subsequent calls to 44 all got a "busy." Then it was a question of several days' work to follow-back and find out why it held-in and how to correct it.

The reason it held-in was that there is always, except at the instant of ringing, a D.C. voltage across the 44 (and all other) line(s), and to remove this D.C. also broke the voice circuit; it was this D.C. which held the relay in, once it had been closed. Eventually, I removed the D.C. by opening one of the relays, on the line-finder associated with line 44, and holding it open with a match. Then the D.C. on line 44 was present only after the ringing relay closed and was released by the caller when the receiver of the phone which had called 44 was restored to the hook. See Fig. 1 for final hookup.

(4) When 44 was dialed the various relays that precede the relays in the above Fig. 1 caused considerable noise in the speakers due to amplification of the contact clicks. This was overcome by adding a copper slug to the armature of the relay which closed the input to the amplifier, causing this relay to pull-in about 1 full second after the others. This is shown in the sketch.

(5) The coupling transformer in Fig. 1 was wound to order in the attempt to get the impedance match between the telephone system and the amplifier as high-quality as possible, and yet cut out most of the lower voice frequencies, as the higher-pitched tones carry better over noisy machinery.

(6) Cross-talk, and proper grounding to eliminate hum and a sound quite similar to "open wire noise" as it is called in Telephone Company employees' talk, was the next stumbling block to be hurdled. While I never found out exactly what caused it, it disappeared after dressing the position of some of the lines from the outside of the switchboard to the amplifier which was located inside the switchboard.

This board is a steel-and-glass case 7 feet high, 10 feet long, and 4 feet deep. Neither this case nor any part of the telephone system was grounded. The power supply to the factory was supplied by a private generating plant, the lines and transformers having been in constant use for 25 years and being about ready to fall apart; the supply is 575 volts, SINGLE phase, 3-wire. For years the factory had had more or less

trouble with the switchboard failing to operate properly, but after an hour or two trouble would clear up, and would seem to the maintenance man to be all right.

Trouble occurred after the amplifier was installed, and upon checking the output of the 575-volt transformer I found that the secondary, which should have tested 115 volts, registered only 96 volts. The Tungar power supply (115-to-48 volts) which fed the switchboard was only producing about 31 volts, and therefore, the phones failed to function. A graph meter installed for a week at the amplifier A.C. cord showed the voltage to vary from 94 to 126 volts! There was not a single ground on the whole business, and so, I had to bond everything together to clear up the trouble.

(7) An oscillator was used to give a "peep" over the amplifier as a time signal, and was operated by contacts on the time clock (see section A, Fig. 2) in accordance with a work schedule. There is also a pushbutton to take care of off-schedule work periods.

Several A.C.-operated oscillators were tried but none worked well, so the battery-operated one as shown in Fig. 3 was built. As the "peep" had to cut off sharp it was necessary to open the plate circuit, hence the 2 circuits to the relay contacts (see left-hand relay in Section B, Fig. 2).

This relay has a copper slug on the armature end of the coil to cause a time delay of about 3 seconds, in order that the power relay which operates the howler can pull-in before the one which operates the oscillator. The reason for this was that there are several other howlers in the vicinity and to distinguish the ones used for time signals in this factory I decided to have the "peep" precede the howl by a few seconds. The time signals are of 15 seconds duration, this period being controlled by the clock contacts. The howler power relay has 2 S.P.S.T. switches tied in parallel to eliminate any contact burning, and has a 0.25-mf. condenser across the points

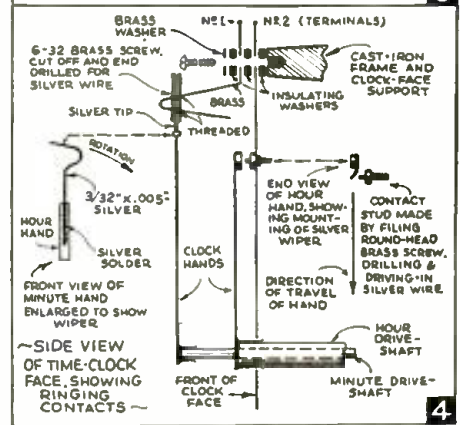
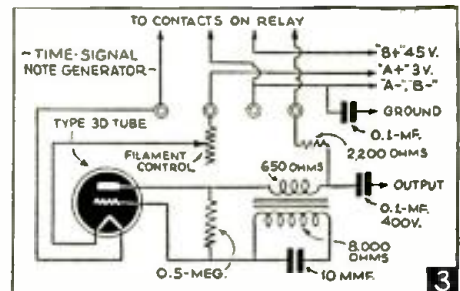

to kill the spark when they opened up.

(8) The radio set is an Emerson which is built into the case; this case also contains the Garrard automatic record player. The dial drive was disconnected and a set of pushbuttons was installed one of which operates the phonograph. The A.C. supply to the combination is controlled by the time clock and can only be used during the dinner period. For special occasions the combination can be operated by means of a Yale key-switch which is in parallel to the time-clock contacts, the key being kept in the office.

(9) The mixer was built for this particular job and has a low-impedance input from the telephone system; it also contains the volume control for the paging system. There is a low-impedance input for the line from the radio-phonograph combination which is located about 200 feet from the amplifier.

(Continued on page 359)

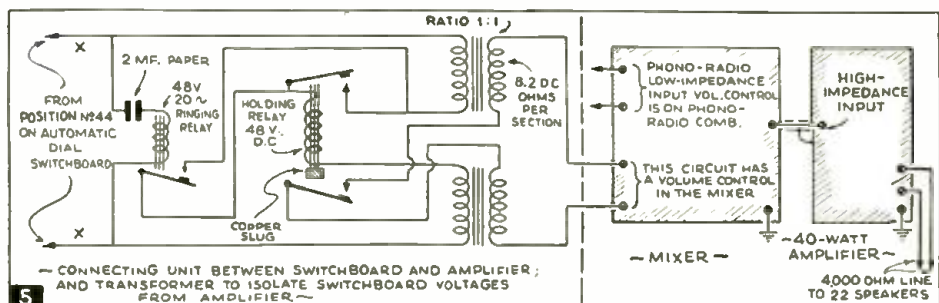

This illustration shows how the relays diagrammed in Fig. 1 connect into the circuit; particularly, into the mixer-amplifier.

# MORE ON STATICLESS RADIO BROADCASTING

The following article represents part of a technical news release. The portions reproduced here, although they duplicate in part, data elsewhere in this issue as well as in preceding issues of RADIO-CRAFT, are presented because of the exceptional clarity with which several important, elementary considerations in the "wide-swing" or Armstrong system of frequency modulation are discussed in connection with the "Staticless Radio" to be inaugurated in Rochester this fall by Stromberg-Carlson.

CONSTRUCTION of a new Armstrong-system frequency modulation transmitting station by Stromberg-Carlson is under way, it was announced last month by E. A. Hanover, vice-president of Stromberg-Carlson, who said a license had been granted by the F.C.C. to operate experimentally on 1 kw. of power.

Upon completion, programs originating from the Stromberg-Carlson-owned station, WHAM, will be broadcast on the frequency modulation band. They will afford the Rochester area its first opportunity to experience "staticless" radio reception with higher fidelity than ever before.

This new transmitter will be located in the Rochester Gas & Electric Co.'s office building and will operate on 43.2 megacycles (an ultra-high frequency wave). The power rating of this new transmitter will be 1,000 watts, but with new antenna systems the power radiated will be equivalent to approximately 4,000 watts as compared to present standard broadcast systems.

## STATICLESS, HI-FI RECEPTION

Major Armstrong's new system has been popularly called "Staticless radio," as tests so far made show that practically all man-made static is eliminated from the transmission when suitable signals are being transmitted and picked up by frequency modulation receivers.

While "staticless" radio is a wonderful advancement in the art, this new Armstrong system appealed to Stromberg-Carlson engineers primarily, as it provides means for transmitting an extremely wide range of audio frequencies necessary to give real high-fidelity reproduction.

Up to the present time, the crowding together of broadcast station channels limited the audio frequency range which can be transmitted and received satisfactorily in a standard broadcast receiver. Only under very special conditions is it possible with present broadcasting systems to transmit and receive an audio frequency range of much in excess of 5,000 or 6,000 cycles. (See "High-Fidelity Broadcasting," August, 1939, *Radio-Craft*, pg. 73.—*Editor*) In Major Armstrong's new system, the channels have been so spaced that audio frequencies as high as 15,000 cycles can be transmitted and successfully reproduced in a broadcast receiver.

Inasmuch as the majority of background noise accompanying the signal in a standard broadcast system resides in the higher frequencies, it is obvious that a "staticless" system (with very little or no background noise) is necessary to permit of utilizing the higher audio frequencies necessary for high-fidelity reproduction.

In this new frequency modulation system, the only background disturbances which can come through are those which are actually picked up by the studio or broadcast station microphone or through the operation of a needle in a phonograph record or program transcription which might be used in supplying the broadcast program. All other noises set up by transmitter tube operation, by "static" and by the operation of the tubes in the radio receiver, which up to the present time produce swish, clicks and crashes, are

done away with; there is no sound coming from the receiver until the announcer's voice or program comes through.

There are a number of other exclusive features in Major Armstrong's system which do away with troubles heretofore encountered in standard broadcasting. For example, a number of frequency modulation stations can be operated on the same carrier frequency with separations of 200 miles or more without any interference, such as cross-talk which now occurs, especially at night, when several stations are operating on the same carrier in an amplitude modulation system. Furthermore, if frequency modulation stations are geographically fairly close together, there is no "nuisance area" in between the stations where signals from various transmitters will come in at about the same volume as is the

## FREQUENCY MODULATION PROGRAMS ON YOUR PRESENT RECEIVER!

Don't get jittery about your present radio receivers each time you hear that another frequency-modulation broadcast station is going or has gone on the air. While the present-day radio set cannot pick up F.M. programs, they can however be adapted for this service by merely adding a frequency-modulation adapter.

Complete constructional details and diagrams on such an adapter will be published in the next issue of *Radio-Craft* as Part II of a series of articles, titled "Frequency-Modulated Programs on Your Present Receiver!". Part I will be found in this issue on pg. 336.

case of the present broadcast systems. This is a valuable operating feature, as it does away with cross-talk which is a very disturbing factor under present standard broadcast operation with a number of stations transmitting on the same broadcast channels.

To sum up, there are 3 distinctive advantages to Major Armstrong's wide-swing frequency modulation system; that is, (1) freedom from static, (2) freedom from cross-talk, and (3) real high-fidelity reproduction.

## LIMITATIONS

There are certain limitations of the system. To begin with, ultra-high frequency signals are radiated the same as light—that is, in a straight line—so that in a flat country, the area of coverage is limited to a distance equivalent to slightly more than the horizon which can be viewed from the broadcast station antenna\*. From experiment, it has been found that increased power projects a useful frequency modulation signal into a section beyond the above-mentioned local area. Thus, one of the prob-

\*This statement is open to some qualification inasmuch as amplitude-modulated signals on even shorter wavelengths than those under discussion have, under exceptional conditions, bridged the distance between both coast!—*Editor*

lems confronting the Stromberg-Carlson engineers is the study of signals in this "fringe area" to determine the requirements for good frequency modulation reception in difficult locations.

In mountainous regions where the broadcast antenna can be placed a thousand or more feet above surrounding terrain, the line-of-sight is greatly extended and experiments have shown that the frequency modulation transmissions in such cases may extend hundreds of miles whereas in level country, the limitation might be 15 to 30 miles.

## NEW "F.M." RECEIVERS

Stromberg-Carlson engineers have been working with Dr. Armstrong since the first of the year in designing suitable receivers for frequency modulation or "F.M." operation and have a complete line including a table model, a medium-priced console, and a large Labyrinth radio with an entirely new audio reproducing system which, it is claimed, gives the finest audio reproduction ever provided in a home-type radio receiver.

While the two larger Stromberg-Carlson receivers are built up around frequency modulation circuit designs, they also provide for standard and shortwave broadcast reception on present amplitude modulation signals.

The smaller receiver is built to receive frequency modulation signals only, and while it has its own speaker and operates as a complete frequency modulation receiver, it has a special output circuit which can be plugged into the phonograph jack of a larger (console) standard broadcast receiver and thus change over a present-day broadcast receiver so that it can operate with frequency modulation signals, as well as amplitude modulation signals.

Furthermore, the loudspeaker used in this small Stromberg-Carlson frequency modulation receiver is so designed as to act as a tweeter (high-frequency reproducer) and work in conjunction with the larger speaker in the console receiver which then will act as a "woofer" (low-audio-frequency reproducer) and thereby provide real high-fidelity operation when receiving frequency modulation programs.

Not only can owners of present standard broadcast receivers get good high-fidelity and staticless reproduction with their present equipment by adding this small, combined frequency modulation receiver and adapter, but also they can purchase new, standard consoles knowing that they will not become obsolete in the near future due to the gradual changing over to frequency modulation for local radio service.

What will become of present amplitude broadcast transmitters? The answer is obvious: that is, the high-powered stations, such as WHAM, which operates at 50,000 watts, will be required to supply broadcast programs for large areas, including rural districts where frequency modulation signals will not be received with adequate strength to be satisfactory. This is especially so in locations where the frequency modulation broadcast antenna cannot be placed several thousand feet higher than the surrounding territory.



## THE RADIO MONTH IN REVIEW

(Continued from page 327)

N. J., a radio amateur for 19 years, put his 900-watt station to good use last month to learn of the plans of his mother, in Tangier, Africa, to return to America. Contact was made by Mr. Bostwick, one of 133 members of the DX Century Club (membership signifies contact has been made with at least 100 foreign stations), via another amateur in Tangier, on 20-meter phone.

Amateur radio stations, 14 of them, have formed an emergency communications system for taking-over the job of maintaining lines of communication with the outside world in the event of a second flood, along the lines of the L. and N. Railway, such as that which struck the line some time ago, an *INS* report from Louisville, Ky., stated last month.

### MISCELLANEOUS

A "television oscilloscope", developed by G.E. engineers and shown on pg. 327, and on the cover of this issue of *Radio-Craft*, was announced last month. It is suitable for the study of wave shapes and transients, the measurement of modulation, the adjustment of radio and television transmitters and receivers, the study of the phase shift in amplifiers, and the measurement of voltage amplitudes. A 9-in. C.-R. tube is used.

A complex sinusoidal signal of 1 $\frac{1}{2}$ -V. at any frequency between 10 cycles and 4 megacycles per second will produce a deflection of more than 4 ins. from peak to peak on the cathode-ray tube. Provision has been made for extremely large deflections when these are necessary.

Any single sine wave frequency between 5 cycles and 6 megacycles per second may be shown in graphical form. The horizontal sweep circuit operates over a range of from 10 to 100,000 cycles per second. Provision has also been made for special features not heretofore available in commercial oscilloscopes.

Mounted on rubber-tired wheels it may be pushed around to any desired location at the transmitter, in the lab. or factory, etc.

The control board now used by N.B.C. engineers and shown on pg. 327 is 1 of 6 units required to complete the master control. According to information released last month, it links field crews and operations directors, and with split-second changeover also feeds the program being broadcast to all points so that any position may take the air immediately. Three rows of red, green and white lights 10 to a line, indicate which positions are on the air, or in communication with the base of operations. This control together with 5 other lightweight units total only 450 lbs., as compared to the old type of master-control unit which it out-modes and which weighed more than 1 $\frac{1}{2}$  tons.

The automatic cueing flash for use in broadcast studios, announced last month by C.B.S., is shown on pg. 327 being scrutinized by (left to right) E. K. Cohan, Engineering, Paul W. White, Director of Public Affairs, and V. N. James, engineer. When a moving red hand reaches the deadline, photo flood-bulbs in the red lanterns on either side flash so brightly that the signal cannot be missed even if the announcer has his back turned.

Sound-movie shorts from Hollywood recently included 2 Pathe News talkies filmed in the N.B.C. studios. One is the RKO Pathe Reelism "Air Waves", and the other, "Television." The first takes the audience behind the scenes in a broadcasting studio and

shows how programs, including sound effects, are prepared and put on the air. The second introduces its topic by showing the manufacture of tubes and other telly equipment; continues to the demonstration of an actual telecast including the use of mobile equipment; and concludes with shots taken at the receiver.

Murray Hill, a pretty little town near Summit, N. J., is the site of a new, \$3,000,000 laboratory building, the 6th unit in a series of lab. set-ups, to be built by Bell Telephone Labs., it was stated last month in an issue of the *New Jersey Bell*. It will have a permanent staff of at least 800 persons.

The remaining Bell Laboratories' experimental and research stations in New Jersey at the present time include (1) shortwave radio experimental units at Deal Beach and Holmdel; (2) the laboratory for development in radio broadcasting (W3XN) at Whippany; (3) the ground station for airplane-to-ground radio telephone development located at Mendham; (4) a tract at Chester for outdoor tests of telephone line-construction materials such as wire, cables, hardware and poles; and, (5) a chemical laboratory at Summit.

The *Queen Wasp*, a newer, faster radio-controlled airplane, it is expected will soon be available for the British Fleet Air Arm and probably will supersede the many radio-controlled *Queen Bees* now available for practice shooting at the Anti-Aircraft camps, according to *Wireless World* (London, Eng.) last month. The older craft, as previously mentioned in *Radio-Craft*, has a speed of only about 80 miles per hour; the newer ship without a soul on board is expected to clip off twice this mileage in the same time.

Imagine a fleet of these, each equipped to release a bomb by remote control, being guided to an objective in enemy territory by a control operator at some distant point as for instance from a camouflaged blimp in the stratosphere!

Pilchard so wearied West Coast fishermen that they have invoked the use of airplanes

## Radio Opportunities in the U. S. Coast Guard

THE UNITED STATES COAST GUARD is greatly increasing its force of enlisted men, having been authorized to enlist 4,300 men for general service, i.e., for service at any place where required for the best interests of the Service. There will be numerous vacancies for radiomen.

Men enlisting for the first time may enlist as apprentice seamen, and will receive immediately upon enlistment a \$100 allowance for uniforms and clothing, and an initial pay of \$21 per month. The Coast Guard maintains its own training facilities, such as a Radio School, a Radio Materiel School, an Engine School and Repair Base, a Yeoman School, a Cooks and Bakers School, and an Armorers School, and also supplies a wide variety of correspondence courses to enlisted men without cost. The requirements for enlistment as apprentice seaman are: Unmarried men, age 18 to 24 inclusive, height 5 feet, 6 inches to 6 feet, 4 inches, minimum weight 122 pounds, grammar school education.

Ex-service petty officers having previously served in the Coast Guard or Navy, and discharged under honorable conditions, may enlist in the Coast Guard as seamen, 1st class, or firemen, 1st class. Ex-radiomen having previously served in the Coast Guard or Navy may be immediately advanced to radioman, 3rd class. The age requirement for former Coast Guard petty officers has been advanced to 40 years.

Application for enlistment or further information may be made to any Coast Guard office. Persons residing in the vicinity of New York, for example, should apply to the U. S. Coast Guard Recruiting Officer, Room 244, Barge Office, Battery Park, New York, N. Y.

Ex-radiomen are invited to call at the Communications Office, Room 415, Custom House, New York, N. Y., at the foot of Broadway.

and radio, according to an *A.P.* report from Hoquiam, Wash., last month, where fish scouts radio to seiners of the fishing fleet when schools of the fish are spotted.

(Continued on page 372)

## NEW FREQUENCY-MODULATION STATION ALLOCATIONS

Data Released by the Federal Communications Commission, Oct. 3, 1939

LICENSEE AND LOCATION	CALL LETTERS	FREQUENCY (KC.)	POWER RATING
Bamberger B'de'st'g. Service, Inc. (Site, in New York City, to be determined.)	W2XWI	43,400	1 Kw.
The Journal Co., The Milwaukee Journal, Milwaukee, Wis.	W9XAO	42,600	1 Kw.
National B'de'st'g. Co., Inc., New York, N. Y.	W2XWG	42,600	1 Kw.
Stromberg-Carlson Tel. Mfg. Co., Rochester, N. Y.	W8XVB	43,200	1 Kw.
Travelers B'de'st'g. Service Corp., Avon, Conn.	W1XSO	43,200	1 Kw.
Westinghouse Elec. & Mfg. Co., Boston, Mass.	W1XK	42,600	1 Kw.
WHEC Inc., (Site, in Rochester, N. Y., to be determined.)	W8XAD	42,600	1 Kw.
Worcester Telegram Pub. Co., Inc., Holden, Mass.	W1XSQ	43,400	1 Kw.
The Yankee Network, Inc., Paxton, Mass.	W1XOJ	43,000	50 Kw.

(See page 379 for an additional listing of High-Frequency Broadcast Stations.)

# OPERATING NOTES

## ANALYSES of RADIO RECEIVER SYMPTOMS

**SERVICEMEN**—What faults have you encountered in late-model radio sets? Note that RADIO-CRAFT will consider your Operating Notes provided they relate to characteristic (repeatedly encountered) faults of a given set model. Payment is made after publication of the Operating Note.

### Trouble with . . .

#### . . . VICTOR 95-T-2

In this model, and in certain similar models by other manufacturers, there is at times a pronounced tendency to howl. This may at first seem to be due to a microphonic tube; but judging by results, it is caused by feedback. Many of these sets leave the factory with the speaker leads lying across the chassis between the A.V.C. and output tubes. Re-routing the wires around the chassis corner eliminates the trouble.

#### . . . G.E. K-62; VICTOR R-12, R-109, RE-41

These models frequently distort on local stations, even when all condensers have been replaced. When they come in for repairs, we do not try to eliminate this fault unless the customers complain of it, as they may be operating the set on a very short aerial.

However, on overhaul jobs, if this distortion appears, we replace the 1st-detector tube with a type 35. Then the grid-return from this tube is removed from ground and connected to the A.V.C. This necessitates boring a small hole in the center of the coil form, near the other terminal, mounting a new terminal to which the end of the coil is attached, then running a wire to the junction of R1, R4 and the A.V.C. choke. In some cases it may be necessary to insert an isolating resistor and bypass condenser. This has cured all cases where distortion remained when the A.V.C. bypass condensers were absolved or replaced.

#### . . . WESTINGHOUSE 101, COLUMAIRE 10

Recently, when checking one of these for overload and "burping" in the output, I had a slight surprise. The reaction was exactly similar to that obtained on another set the same day, and which was traced to gassy type 45's. Replacing each of the output tubes did not eliminate the effect, but did alter the "burp" frequency.

All who have serviced this set, or similar models of G.E. or Victor, will understand my

reluctance to remove the chassis. However, it seemed necessary. Imagine my disgust upon finding a 0.05-mf. bypass condenser, shorted, across the power bias resistor. The owner stated that the set had previously only been serviced by the factory, and as he worked there, it seemed likely. I removed the defective condenser, and the set worked like new. A new bypass was mounted for psychological effect; certainly no physical effect was noticeable.

#### . . . A.V.C. Troubles

—Early RCA, Zenith and Kolster

In a number of different makes of radio sets which several years ago used separate A.V.C. tubes not operating as diodes, various troubles were noted which seemed directly due to the complexity of the circuit. By this I mean that a somewhat simpler circuit would give less trouble to both set-owner and Serviceman; though it might cost more in royalties. Early R.C.A., Zenith and Kolster sets have been the chief offenders. Our solution to the problem has been to change over the A.V.C. tubes to diode connection, à la Philco; and presto, new set performance. This arrangement has not only solved many difficulties in existing A.V.C. systems; but has proved satisfactory in modernizing sets that previously did not have A.V.C.

THOMAS C. RUMNEY,  
Toronto 3, Canada.

#### . . . MAJESTIC M-25

—Home Made "Spray Shielding"

Some time ago I had to service a Majestic M-25 receiver using my pet headache, "spray shield" tubes. The oscillator tube, a type 27S, would not work over part of the dial but a new, standard glass-27 worked fine, the owner however insisted that he must have a spray-shielded tube in the set and none was to be had within a hundred miles, so I decided to give him my own brand of spray shielding.

Taking a tube of the widely-sold "liquid solder," I gave the glass-27 a thin, even coat; result, a perfect spray-shielded tube

with which the owner and myself were both satisfied.

GUY E. MCALLAN,  
Trinity Auto Electric,  
Fernie, B. C., Canada.

#### . . . ARVIN 1427

I recently had a repair job on an Arvin 1427. The quality of reproduction was very much impaired; also, after the set heated up, the volume would slowly decrease to almost nil.

Upon checking the set over thoroughly the trouble was traced to the audio section. Rather than replace any parts, for such replacements might later cause trouble, it was suggested I try a different type of circuit, one that would render much better quality with practically the same amount of output. The change was very easily made without very much trouble and with very little in the way of parts.

Both the original and revised circuits are reproduced here. (See diagram.)

Note the absence of the driver transformer; and that the input stage coupling to the 6C5 driver has been changed. The tone control was moved up to the input stage leaving the 2nd 6C5 to function properly as a phase inverter. The quality is 100% better and the amount of output is about the same as with the old circuit. Other Servicemen who run into the same trouble with this particular type of set would do well to change the audio system to the revised one shown. No more trouble has arisen with this particular set and it still makes the owner happy to think he had a bright idea once.

WALTER FERNALD

#### . . . FORD-PHILCO F1514

The volume control needed replacement and we were unable to obtain an exact mid-get duplicate so we substituted a standard-size unit of proper resistance with a very short knife-blade shaft. The old control had a short knife-blade shaft inside a short tube. The split shaft of the control cable must be ground or cut back 1/8-in. for free operation. Inasmuch as the speaker and dial assembly bolt directly over the volume and tuning control positions, this unit works perfectly, and being of a larger size than the original has much longer life.

#### . . . GENERAL ELECTRIC RADIO

—The type with sliderule dial and moving pointer

The cable broke and the customer lost the pointer. I went to a jeweler and got a slim, fine-pointed clock-hand. By bending this hand to proper shape and spot-welding it to the cable the job was done in fine shape. Care must be exercised in heating the hand to a dull red, at the point of bend, before bending or it will break.

#### . . . ADMIRAL

An 8-tube, 4-waveband table model Admiral with spinner dial kept cutting-out.  
(Continued on page 377)

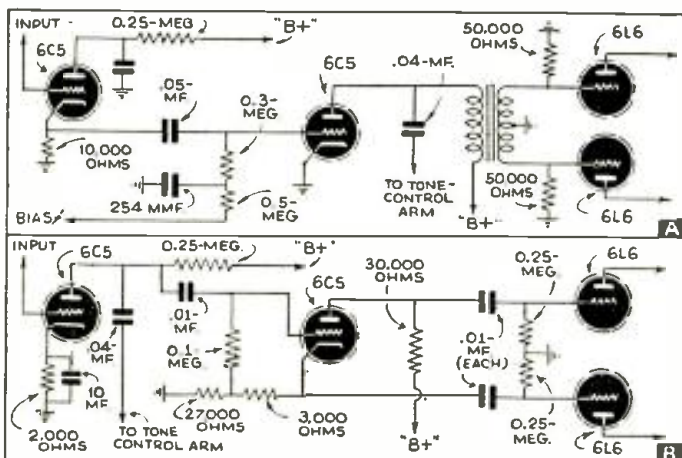

A.—The Arvin model 1427 as originally wired.  
B.—The new circuit as revised by Mr. Fernald for improved performance.



All the worthwhile  
Radio Trade News  
of the past Month—  
Digested for busy  
radio men.

# RADIO Grade Digest

A PLEDGE: — To  
print the important  
news of the radio  
industry; to review  
major news events;  
to help point a path  
to radio profits.

IMPORTANT HAPPENINGS OF THE MONTH IN THE RADIO INDUSTRY

No. 16

DECEMBER, 1939

No. 16



*Flash!* That widely-publicized "big-screen long-range" television system over which the newspapers went crazy turns out to be nothing but the old Kerr cell-PE. cell low-definition job that major companies discarded years ago, if our Western correspondent knows his oats . . . . A pat on the back to *Radio Wire Television, Inc.* for sending "thank you" cards telling those who asked for catalogs that shipment would be slightly delayed; most companies just let their customers wait & wait & wait . . . . Bright spot in battle—the first World War boomed record sales to 161% of the 1913 level by 1917. It's an ill wind, etc.

Simpson Elec. Co.'s *Model 325 Giant Tester* has a rectangular meter with a full 9-in. scale for easy reading—lots of other features, too . . . . A new 100% synchronous motor is being put out by Universal Microphone Co.'s recording division . . . . Is radio a career? Why, Columbia University, N.Y.C., is even putting out 2 courses—"Radio Today" & "Radio Writing" . . . . University of Nebraska which has a correspondence course in radio servicing is using Alfred A. Ghirardi's book *Modern Radio Servicing as a standard text* . . . . All Du-Mont television receivers now use the new & brighter intensifier type CR tube; there are 3 models in the line . . . . Cute idea on Triumph Mfg. Co.'s new "automatic" Visograph tube checker is illuminated colored tube facsimiles which give direct "good", "bad", and "replace" readings that public can understand.

Fibre glass mats of new design are used as the separators in the new *B. F. Goodrich Co.* "Glasstex" storage bats, which are guaranteed for 27 mos. (or 27,000 mi. if used in a car) . . . . *Graybar Elec. Co.* is holding 6 dealer meetings in as many cities to introduce *Majestic* radio & telly sets to dealers in N.Y. state & Pittsburgh . . . . Any metal with any style, size and thread system is the latest word from *Elastic Stop Nut Corp.* These nuts have resilient non-metallic collars to take up thread play.

Congratulations to *General Elec. Co.* which just knocked off an order from the Army for more than \$2½ million worth of radio equipment for our Air Force . . . . Features of new *Brush Development Co.*'s type BJ phones include pokeless cord, soft rubber jacket & hermetically-sealed aluminum cartridge . . . . G.E. got tips from visitors to its exhibits at the N. Y. World's Fair; these helped it improve its line.

## TELEVISION TRENDS

According to *Radio Daily* (& ooh! how we hope they're right!) big television boom will start in New York this autumn. According to this report, *CBS & Du Mont* will be on the air with elaborate shows. (Wanna bet?) Also rumor that *G.E.*'s Schenectady station, *Philco, Farnsworth & Don Lee*, out of New York, will conduct elaborate experiments.

*Variety*, standard publication of show biz, now runs television feature. Their estimate is that only 350 sets retailing at \$400 to \$650 were sold in New York area up to mid-June. Estimate weekly operating expense of *RCA-NBC* programs \$2,500 inclusive of everything (we think they're low).

*University of Iowa* has requested shift to 50-56 mc. channel with power of 250 W.

*Ned Wayburn*, dance master, has opened a studio for radio & television production in N.Y.C.

## EASY INSTALLATION JOB



Lafayette's new BB-7 phono-radio has built-in broadcast and shortwave loops, automatic record player, pushbutton tuning, etc. Covers 22 mc. to 528 kc. in 3 bands. Just plug it in & it plays, simplifying usual installation problems.

## Sales Helps and Deals

### New Paths to More Business

All *STEWART-WARNER* receivers now in production that have phonograph terminals bear bright red 4¼ x 2¼ in. tags boldly-lettered "NOTICE! This Receiver is wired for Television." Each distributor has already received 50 such tags for use on sets in his or dealers' stocks. Letter from *Stewart-Warner* accompanying sample tag explains that any set with "phono" terminals can be used to reproduce audio output of television set not containing audio end.

*UNIVERSAL MICROPHONE CO.* is readying a special campaign for dealers who wish to assemble case displays of recording needles and styli to use in conjunction with recording machines, blanks & similar equipment for holiday trade.

"Televents", a large green & black card issued by *DU MONT*, gives a pictorial program of weekly television broadcasts for use in dealers' windows & stores. Idea is that public will buy more telly sets if good programs are brought to their attention.

*CALIFORNIA REFRIGERATOR CO.* gave xala show with freaks, dance prizes, gags, community singing & other amusing features to open their new store in Oakland. If anything will pull the crowds, this stunt certainly should.

*HYGRADE SYLVANIA CORP.* continues personalized blotter campaign with illustration & text featuring precision of *SYLVANIA* tubes.

## \$'s & N<sup>o</sup>. 's Dept.

New *CBS* survey shows that net's listeners out of all radio families are:—94% in N.Y.C., 88% in Chi., 93% in Phila., 97% in Boston, 95% in St. Louis, 99% in Balt., & 87% in rural areas throughout U.S.

## GETS 1ST SPECIAL UNIT



Left to right: *D. W. May*, mgr. of *G.E.*'s N.Y. distrib. turning over to *E. F. Jeffe*, v.p. in charge of sales of *Consolidated Edison Co.*, the 1st phono-radio in the co.'s new bargain offer.



## Salesman Sam Says:—

*(Editor's Note: Despite the War there may be some business to be had abroad but any manufacturer who does not get cash on delivery & transfer title in the U.S. is taking an awful gamble with his merchandise & stockholders' wampum.*

*(Do you hear Opportunity knocking—hard? It's the S.A. market, orphaned by the warring nations. WHAT ARE YOU DOING ABOUT IT?)*

**POLAND**—Gov't. issues report as of Sept. 12, 1939—but use your own judgment.

**FIJI ISLANDS**—About 900 sets in use among 200,000 population; 75% are all-wave; most current 240 V. D.C. with a little 110 V. A.C. Market negligible.

**NEW HEBRIDES**—Market negligible.

**BULGARIA**—55,000 sets in use by 6 million population. German & Dutch mfrs. give up to 2 yrs. credit to dealers. About 15,000 sets were sold in '38. Most popular types are 5 & 6 tubes, including short- & medium-wave bands. Current in Sofia, 150 V., 50-cycle, A.C.; other towns, 120 & 220 V., 50-cycle, A.C., with a few having 220 V. D.C.

**HAITI**—2,700 sets in use by 2,700,000 population. Only about 300 sold last year; 8- to 11-tube all-wave sets popular. Priced from \$115 to \$150. Mostly 110 V. A.C., 50-60 cycles. Market negligible.

**LIBYA**—8,500 sets in use by 900,000 population. Annual sale about 500. Little chance of cracking market.

**NETHERLANDS INDIA**—About 71,000 sets in use by 61,000,000 population. Sale in 1938, 16,447. Low-priced sets (\$12.50 to \$15) popular. Good market at this price if of all-wave type. (!)

**ARGENTINA**—1,000,000 sets in use by 12,750,000 population. Importers usually get 50% or more off list. Annual sale about 200,000 sets with rise beginning in Mar. or Apr. Biggest sale 5-tube

medium- & short-wave table model. Price about \$60 for imported jobs competing with about \$40 for domestic jobs. (This bulletin well worth getting for your files.)

**NETHERLANDS**—Approx. 600,000 sets in use by 8,000,000 population. Virtually a closed market due to patent situation.

**MARTINIQUE**—3,500 sets in use by 250,000 population. Annual sale 350 to 400 sets.

**EGYPT**—About 82,000 sets in use by 16,000,000 population. About 1,400 sets sold last year. American sets favored but Europeans getting much business. (This bulletin worth getting for your file.)

**PALESTINE**—About 35,000 sets in use by 1,400,000 population. About 7,000 sets sold last year; 6- to 8-tube all-wave table models most popular; 220-V. 50-cycle A.C.

**GUATEMALA**—14,000 sets in use by 3,000,000 population.

**NORWAY**—About 360,000 sets in use by 3,000,000 population. Estimated about 70,000 sets sold last year, nearly half of which retailed below \$30; 5- and 6-tube superhets favored though slightly higher in price. (This bulletin worth obtaining for your files.)

**SWEDEN**—About 1,280,000 sets in use by 6,500,000 population. Sales last year about 200,000 sets, 60% of which were domestic. New regulations on electric jobs will cut American sales further; 5- & 6-tube, 3-band A.C. jobs favored. Current is 120 & 220 V. D.C. & 127 & 220 V., 50-cycle A.C.

**AFGHANISTAN**—300-1,000 sets in use by 12,000,000 population. Market negligible.

**GUADELOUPE**—3,500 sets in use by 265,000 population. Annual sale 350 to 400 sets. All-wave 110 V., 60-cycle A.C. jobs favored.

**EL SALVADOR**—10,000 sets in use by 1,500,000 population. Annual sales 1,500-2,000; 8- to 11-tube all-wave 110 V. 60-cycle A.C. table models preferred.

**RUMANIA**—275,000 sets in use by 20,000,000 population. Annual sales about 22,000. Mostly German imports.

**GILBERT and ELLICE ISLANDS**—Market negligible.

**BRITISH GUIANA**—1,800 sets in use by 350,000 population. Annual sales about 50 sets.

**BRITISH SOLOMON ISLANDS**—47 sets in use by about 95,000 population. Market negligible.

*Far more detailed information is available from the Bureau of Foreign & Domestic Commerce, Washington, D.C. Publications to request are: World Radio Markets covering countries wanted & The Electrical & Radio World Trade News.*

## Personal

These men are worth knowing; meet them here.



Left to right, JOE and JOHN ERWOOD are v.p. and pres., respectively, of the newly-formed Erwood Sound Equipment Co. After 15 years in the sound biz. these boys have started their own co. to specialize in the sound field exclusively. JOHN will be in charge of sales work, JOE in charge of engineering. Line will cover portables, fixed installations, institutional, school & industrial systems, inter-office communicators, & everything else you can think of.

KENDALL CLOUGH, pres. & chief eng. of Clough-Brengle Co. has taken over personal direction of his co.'s instrument sales. FRED WELLMAN, sales head until now, continues as v.p. & adv. counsel.

ALFRED A. GHIRARDI, radio writer & consultant, is making a detailed survey of technical texts for United Technical Publishers Co., N.Y.C.

MARK B. LAJOIE has replaced LEONARD F. CRAMER as gen. sales mgr. of Allen B. DuMont Labs., Inc. Lajoie has been in radio since 1922; among his previous jobs was 10 yrs. with Nat'l Carbon Co. Mr. Lajoie is pictured to the right.

LEONARD F. CRAMER, former sales mgr. at DuMont, assumed that position at Wire Broadcasting, Inc.



JAMES LAWRENCE FLY, new chairman of the F.C.C., was born at Seagoville, Tex. So it was only natural for him to attend the U.S. Naval Academy & enter the Navy, from which he resigned in 1923. He was a Special Assistant U.S. Attorney-General from '29 to '34 when he became head of the Legal Dept. of TVA. He joined the F.C.C. in '39 & was sworn-in as Chairman in Sept. to run until June 30, '42.

MANLY E. LORD of Schenectady has succeeded NEIL CURRIE, JR. as mgr. of G.E.'s Fort Wayne works. Mr. Currie has become v.p. in charge of mfg.

KENNETH O. TINKHAM, mgr. of Station KMTR, Hollywood, Calif., has flown 100,000 mi. & so has been made a member of United Air Line's "100,000 mi. club."

CHARLES R. D'OLIVE succeeds J. F. DITZEL, as mgr. of Stewart-Warner's household appliance div.

JOHN F. RIDER, radio writer, is conducting a series of meetings for radio Servicemen in 35 U.S. cities. Each meeting will be sponsored by RCA & its local distrib.

CHESTER H. LANG, adv. mgr. of G.E. is chairman of the co.'s new committee on advertising. Other committee members are B. W. BULLOCK of Bridgeport, Conn. and H. F. BARNES of Cleveland, O.

"CHARLIE" SICURANZA, capable equipment designer well-known to Radio-Craft readers, was appointed Chief Assistant to American Television Corp.'s electronic specialist, MARSHALL P. WILDER.

"BOB" EICHBERG, RTD Editor, is "Bob Brent," master of ceremonies on NBC television's "Visi-Quiz."

## KIDDIES' KLUB FOR DISCS



Berdie Borenstein, record buyer of Gimbel's Milwaukee store, has hot idea to boost sales of tot records. Neighborhood youngsters club their pennies and buy RCA Victor Children Record Albums. Kids rotate the discs from home to home.



# AN EDITORIAL

By Artie Dee

It's murder, that's what it is! Yes, here is a swell business—all ready for the trade to make some sales that really amount to something—and it is being slowly murdered by the very men who stand to profit most by it.

The business is Television and its murderers are the dealers, the manufacturers and broadcasters.

You, Mr. Dealer, are undoubtedly doing your part to kill the ostrich which should lay tremendous golden eggs for you, if not now, in the near future. The chances are 1,000 to 1 that, if television has not yet commenced its broadcasts in your area, you tell your customers to get thoughts of this new art out of their minds—that television "is still 5 years away." When it breaks right around the corner from you, next year, you will find that you have talked yourself out of some nice \$200 to \$600 sales.

If television broadcasts are taking place in your territory and you are not demonstrating sets, you are passing up sales which should be yours. Even if you are demonstrating sets, the chances are

## Your Poor Demonstrations

500 to 1 that your installation is so poorly made and planned that you unsell your customers rather than sell them. You are probably getting ghosts, or transients, or distortion on your screen—or have your sets so located that screen illumination must be stepped up to a point where definition is decreased. Check up on yourself and put things to rights.

Finally, if you have sold a few sets the chances are about 5,000 to 1 that the installation is not of a type that will make visitors to the home where the set is installed enthusiastic boosters—and purchasers—of television. Remember! Every set you sell is a demonstrator for you. Make each installation as perfect as humanly possible.

Dealers are not alone at fault. Even

## EXPORT SET WOWS U.S.



Designed for export use & therefore "built to take it," RCA's Tropic Set with wide shortwave coverage is getting big play from airline execs., pilots, & others. 604 tunes from 13 to 62 meters.

## Changes & New Addresses

Where to Reach Old and New Companies

LAUREHK RADIO MFG. CO. has moved offices, factory & labs. to 3918 Monroe St., Wayne, Mich.

LAUREHK MFG. CO., same address, will sell all prods. (hearing aids, phono-radios for educational institutions, Audiometers & other equip't for the hard-of-hearing) made by the above-mentioned co.

the most costly television sets are frequently shipped from the manufacturers without being precisely aligned. Of course television is new and we all still have a lot to learn! But alignment is a simple factory procedure, isn't it?

Broadcasters cannot escape their share of blame. True, programs are entertaining—and if one owns a television set he will get many hours of real enjoyment from it. But the programs are not of such a nature that the casual looker-in will say to himself, "Have I been missing this all my life? I'm going to buy a set tomorrow."

The solution is simple. While sales are few, manufacturers should not only see that every set is perfect when it leaves the factory but that it is perfectly installed. Dealers should see that all installations are as good as is possible—particularly the installations of demonstrators. And, finally, broadcasters should give a little more thought to producing eye-grabbing shows.

## OFF THE PRESS

Latest Publications to Keep You Informed

CATALOG NO. 40. J. W. Miller Co., Los Angeles, Calif., 32 pp. Gives ready reference to coils & other components, including complete kits.

CATALOG. Garrard Sales Corp., N.Y.C., 16 pp. Shows complete line of automatic record changers, motors, pickups & turntables.

TRANSFORMER CATALOG NO. 400-D. Thordarson Electric Mfg. Co., Chicago, Ill., 24 pp. Complete data on this co's. transformer line, including tropical models.

CIRCULAR 507. Ward Leonard Elec. Co., Mt. Vernon, N.Y., 4 pp. Wire-wound Adjustohm & plaque resistors, ring-type rheostats, line voltage reducers, parasitics suppressors & antenna loading inductances are described.

CATALOG NO. 57-J. American Phenolic Corp., Chicago, Ill., 32 pp. Pictures & descriptions of Amphenol products, including sockets, connectors, coaxial cable, rods, sheet, tubing, etc.

CATALOG. Precision Apparatus Co., Brooklyn, N. Y. Illustrates over 40 models in test equipment line.

BULLETINS 16 & 17. Miles Reproducer Co., Inc., N.Y.C. These pamphlets illustrate & describe new Filmgraph instantaneous recorders & reproducers— & describe various applications.

CATALOG NO. 89. Radio Mfg. Engineers, Inc., Peoria, Ill., 12 pp. Lists line of R.M.E. expanders, preselectors, communications receivers, oscilloscopes, amplifiers, noise suppressors, I.F. transformers & other products.

CATALOG. Elastic Stop Nut Corp., Elizabeth, N. J. Explains principle and lists standard nuts.

CATALOG. Simpson Elec. Co., Chicago, Ill. Describes new Model 325 giant tube tester.

## BEAUTY AND THE BEACH



To show that Model 05-5L1 portable, one of 6 new 1940 Stewart-Warner sets will play anywhere, enterprising L. L. Kelsey, co.'s sales mgr., put this cre on the beach & surrounded it with nice scenery.

## WAR NEWS ROOM DRAWS CROWDS



Eastern-Columbia Clothing store in Los Angeles put KEHE news-room in window, drawing mammoth crowds. Display of this type is natural for radio store. Try it and boost biz.



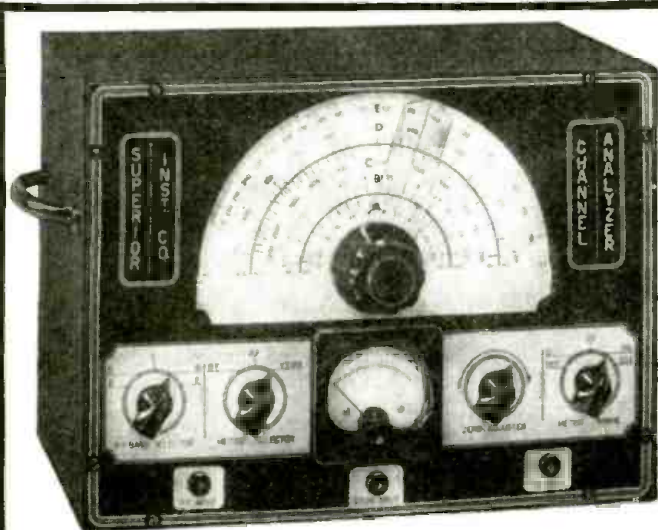

THE NEW

# CHANNEL-ANALYZER

Follows Signal from Antenna to Speaker of Any Set

### THE CHANNEL-ANALYZER WILL—

1. Follow signal from antenna to speaker through all stages of any receiver ever made.
2. Instantly track down exact cause of intermittent operation.
3. Measure both Automatic-Voltage-Control and Automatic-Frequency-Control voltages and circuits without appreciably loading the circuit, using built-in highly sensitive Vacuum-Tube Voltmeter.
4. Check exact gain of every individual stage in receiver.
5. Track down and locate cause of distortion in R.F., I.F., and A.F. amplifier.
6. Check exact operating voltage of each tube.
7. Locate leaky condensers and all high-resistance shorts, also show opens.
8. Measure exact frequencies, amount of drift and comparative output of oscillators in superhets.
9. Track down exact cause of noise.

Fundamentally, what the Superior Channel-Analyzer does is to permit the serviceman to follow the **SIGNAL** from antenna to speaker through each and every stage of any set ever made, and inferentially, of any set that ever will be made, using the **SIGNAL** as the basis of measurements. Thus if there is trouble in one particular channel or stage of a receiver, the serviceman can isolate the faulty stage and then proceed to ascertain the very part or component that causes the trouble.

Many of the troubles in modern receivers are due to the Automatic-Voltage-Control and Automatic-Frequency-Control circuits and ordinary instruments do not permit measurements directly upon these circuits, so the Superior Channel-Analyzer includes a direct-current Vacuum-Tube Voltmeter that **DOES** make these measurements directly and with a negligible loading of the measured circuits.

Other problems cease to be problems too, when the quick-solution method of the Channel-Analyzer is applied. For instance, suppose a local oscillator in a superheterodyne drifts. The Channel-Analyzer has a switch operated, tuned input circuit with amplifier, whereby not only the presence of drift may be discovered, but also the amount and direction of drift.

Distortion is another difficulty that often nettles a serviceman. The Channel-Analyzer has a jack for the insertion of earphones so that you can listen to the signal directly from any stage and, therefore, discover the stage in which the distortion takes place. Next, the VTVM is used to discover the very component in that circuit that is causing the trouble. How often have you cherished the hope that someday you would own an instrument that enables you to measure the actual signal voltage across the load of any stage in the set, and thus by comparison determine the gain per stage. The Channel-Analyzer enables those dynamic voltage measurements and does a whole assortment of other work besides, yet

at a price much less than that usually asked for a dynamic voltmeter alone. D.C. Voltages have important bearings on receiver performance. All these voltages can be measured on the Channel-Analyzer with the receiver in reproducing operation. In fact, that one important consideration, **MEASUREMENTS WITHOUT MOLESTATION OF THE RECEIVER**, gets rid of the drawback of most conventional equipment which greatly reduces the very voltage it attempts to measure, or kills the signal completely. Tubes that are used in the receiver under test are also given a thorough check by the Channel-Analyzer and as such a specialized tube tester, this new and remarkable instrument is proof against any possibility of obsolescence. Noise, another serious problem to servicemen, can be located with the aid of the Channel-Analyzer and can be done with incredible speed. Here are the basic components of the Channel-Analyzer:

1. B Supply rectifier and filter circuit.

2. One-stage, high-gain flat amplifier and linear diode detector.

3. Tuned-circuit, high-gain amplifier and linear diode detector, 100 KC. to 20 MC.

4. D.C. Vacuum-Tube Voltmeter, for measuring the rectifier R.F., I.F. or A.F., and for independent use on external circuits, all by front panel switching.

By adroit engineering and skillful application of a wide knowledge of servicing requirements based on Superior's years of experience, the four components listed above are made to do so many things and do them so well and fast that a large benefit is bestowed on servicemen, their tasks lightened, their work speeded and their experience greatly extended, all at record-breaking low price.

**\$19<sup>75</sup>**

## THE X-RAYOMETER FEATURES NEW

**GIANT 9 INCH METER—AND A BUILT-IN POWER SUPPLY ENABLES RESISTANCE MEASUREMENTS UP TO 30 MEGOHMS**

### SPECIFICATIONS

- RESISTANCE MEASUREMENTS IN 3 RANGES: 0-1000 Ohms, 0-100,000 Ohms, 0-30 Megohms.
- D.C. VOLTAGE MEASUREMENTS IN 5 RANGES: 0-50, 0-250, 0-500, 0-1000, 0-2500 Volts. Television and other high voltage power supply circuits easily measured.
- A.C. VOLTAGE MEASUREMENTS IN 4 RANGES: 0-50, 0-250, 0-500, 0-1000 Volts.
- D.C. CURRENT MEASUREMENTS IN 6 RANGES: 0-1 Ma., 0-50 Ma., 0-250 Ma., 0-1 Ampere, 0-10 Amperes, 0-25 Amperes. High current ranges suitable for automotive and industrial work.
- CAPACITY DIRECTLY READ ON METER SCALE IN 2 RANGES: 0-5-1 Mfd., 0-2 Mfd.-50 Mfd.
- PERCENTAGE OF LEAKAGE of electrolytics read **DIRECTLY** on meter scale. Actual condition of condenser quickly determined.
- INSULATION, INTER-ELEMENT and A.V.C. LEAKAGES directly read on meter scale up to 30 Megohms.
- OUTPUT MEASUREMENTS IN 4 RANGES: 0-50, 0-250, 0-500, 0-1000 Volts. Built-in blocking condensers enable rapid alignment of radio equipment.
- INDUCTANCE MEASUREMENTS IN 2 RANGES: 0-7 Henries, 7-703 Henries.
- DECIBEL MEASUREMENTS IN 3 RANGES: D.B. based on 6 M.W. at 500 Ohms, -10 to +20, -10 to +45, -10 to +49. Audio frequency measurements in both radio and P.A. amplifiers.

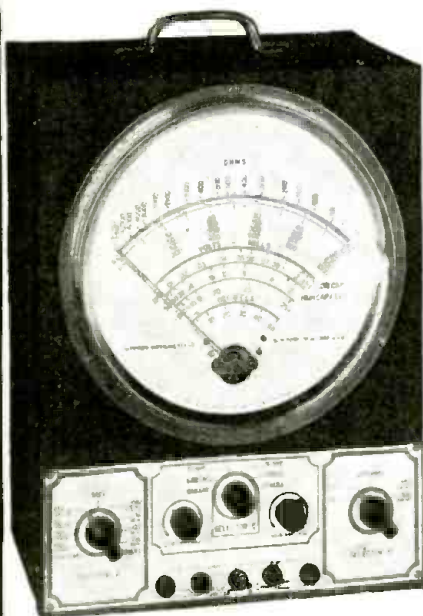

X-RAYOMETER comes housed in a new army gray crystalline, heavy gauge cabinet. Complete with test leads, instructions and tabular data. Shipping weight 20 pounds.

**\$17<sup>95</sup>**  
ONLY

## THE NEW MODEL 1130-S SIGNAL GENERATOR WITH AUDIO FREQUENCIES



### SPECIFICATIONS

1. Combination R.F. and Audio Signal Generator. R.F. 100 kc. to 100 mc. A.F.—100-7500 cycles. All direct readings, all by front panel switching.
  2. R.F. and A.F. output independently obtainable alone or with A.F. (any frequency) Modulating R.F.
  3. Accuracy is within 1% on I.F. and Broadcast bands; 2% on higher frequencies.
  4. Audio frequencies in 5 bands: 100, 400, 1000, 5000, and 7500 cycles.
  5. Giant airplane full vision, direct-reading dial.
  6. Condenser and other leakages tested to 100 megohms.
  7. All services on 90-130 volts A.C. or D.C. (any frequency).
- Model 1130-S comes complete with tubes, test leads, carrying handle and instructions. Size 12"x9"x6 1/2". Shipping weight 15 lbs. Our net price

**\$11<sup>85</sup>**

**SUPERIOR INSTRUMENTS COMPANY**  
136 Liberty Street Dept. RC-12 New York, N. Y.

Please Say That You Saw It in RADIO-CRAFT



### THE MODEL 1110 A.C. - D.C. VOLT-OHM MILLIAMMETER

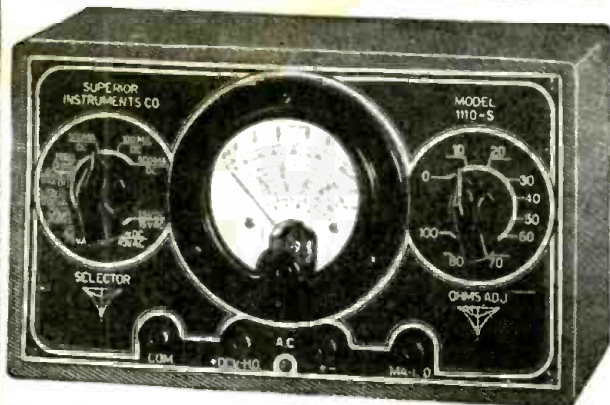

We could have priced this instrument for \$1.00 or even \$2.00 less by taking advantage of certain economies, which would not have made much difference in the performance of this instrument. However, we realize that this type of instrument must be built to withstand an unusual amount of abuse. We, therefore, used the very best of parts in designing and building this instrument. For instance, we use the same type of jewelled d'Arsonval type of meter as in our larger units, precision multipliers and shunts, positive contact switches and tip jacks, wirewound ohms adjuster and an attractive etched aluminum panel. Thus at \$7.85, a low price for a pocket-size A.C.-D.C. Volt-Ohm Milliammeter, we offer an instrument which compares favorably with the same type of instrument selling at twice the price.

**SPECIFICATIONS:**

0-1.5 volts D.C.	0-500 ohms	500-500,000 ohms.	0-15 volts A.C.
0-15 volts D.C.	0-1 ma.	D.C.	0-40 volts A.C.
0-25 volts D.C.	0-10 ma.	D.C.	0-75 volts A.C.
0-75 volts D.C.	0-100 ma.	D.C.	0-200 volts A.C.
0-500 volts D.C.	0-500 ma.	D.C.	0-1200 volts A.C.

Model 1110-S supplied complete with batteries, test leads and instructions. Size 8 1/2" x 5" x 3 1/4". Shipping weight 5 1/2 pounds. Our net Price **\$7.85**

### THE NEW MODEL 1280 SET-TESTER

Combines Models 1240 and 1250

A complete testing laboratory in one unit, the Model 1280 combines the Models 1250 Multitester and 1240 Tube Tester. (See specifications of each below.)

**FEATURES**

- ★ Instantaneous snap switches reduce actual testing time to absolute minimum.
- ★ Spare socket, and filament voltages up to 120 volts make the Model 1280 obsolescence proof.
- ★ Latest design 4 1/2" d'Arsonval type meter.
- ★ Works on 90-125 volts 60 cycles A.C.



Even those servicemen who through past purchases know they can always get SUPER-VALUES from Superior, will be amazed and delighted when they read the specifications of this all-purpose instrument and then note the unbelievably low price. The Model 1280 features a 4 1/2" d'Arsonval type meter for easy reading of the various scales, and in line with our new policy of stressing appearance as well as serviceability in our new 1280 line of test equipment, our Model 1280 utilizes an aluminum etched panel, designed for beauty as well as ruggedness. The primary function of an instrument is, of course, to make measurements accurately and when designing test equipment this is our first thought. However, we also appreciate the important part the appearance of an instrument plays in the impression a serviceman makes on his customers, especially on home calls. We have, therefore, paid special attention to the outward design of all of our new instruments. For instance, the panel of this Model 1280 is made of heavy-gauge aluminum and etched by a radically new process which results in a beautiful, confidence inspiring appearance.

Model 1280 comes complete with test leads, tabular data and instructions. Shipping weight 18 pounds. Size 13" x 11" x 6 1/2". Our net price **\$19.95**  
Portable cover \$1.00 additional.

### THE NEW MODEL 1250 MULTITESTER



Sloping panel for precise rapid servicing.

Etched aluminum panel

Specially designed electronic rectifier enables linear A.C. scale, high stability and little or no temperature drift.

Here is an opportunity to acquire a Multi-Service, Precision Engineered Instrument, for less than you would have to pay for an ordinary Volt-Ohm Milliammeter. Besides making the usual volt, resistance and current measurements (both A.C. and D.C.) this unit accurately measures the CAPACITIES of mica, paper and electrolytic condensers. INDUCTION of coils, chokes and transformers, DECIBEL gain or loss, of power amplifiers and public address systems. WATTS output of amplifiers, receivers, etc.

**SPECIFICATIONS**

Complete A.C. and D.C. Voltage and Current Ranges	High and Low Capacity Scales
D.C. Voltage:—0-15, 0-150, 0-750 volts	.0005 to 1 mfd. and .05 to 50 mfd.
A.C. Voltage:—0-15, 0-150, 0-750 volts	3 Decibel Ranges
D.C. Current:—0-1, 0-15, 0-150, 0-750 ma.	—10 to +19, —10 to +38, —10 to +53
A.C. Current:—0-15, 0-150, 0-750 ma.	Inductance: 1 to 700 Henries
2 Resistance Ranges	Watts: Based on 6 mw. at 0. D.B. in 500 ohms. 006000 to 600 Watts
0-500 ohms, 500-5 megohms	

Model 1250 works on 90 to 120 Volts 60 cycles A.C. Comes complete with test leads, tabular charts and instructions. Shipping weight 9 pounds. Size 9 1/2" x 11" x 6 1/2". Our Net Price **\$11.85**  
Portable Cover \$1.00 Additional

### THE NEW MODEL 1240 TUBE TESTER

Instantaneous snap switches reduce actual testing time to absolute minimum.

Tests all tubes 1.4 to 117 volts.

Sockets for all tubes—  
No adapters.



Superior is proud to offer the newest and most practical tube tester ever designed. Unbelievably low in price—unbelievably high in performance.

- ★ Tests all tubes, 1.4 to 117 volts, including 4, 5, 6, 7, 1L, octals, locals, Bantam Jr., Peanut, single ended, floating filament, Mercury Vapor Rectifiers, the new 8 series, in fact every tube designed to date.
- ★ Spare socket included on front panel for any future tubes.
- ★ Tests by the well-established emission method for tube quality, directly read on the GOOD ? BAD scale of the meter.
- ★ Level protected neon.
- ★ Tests shorts and leakages up to 2 megohms in all tubes.
- ★ Tests leakages and shorts in all elements AGAINST all elements in all tubes.
- ★ Tests BOTH plates in rectifiers.
- ★ Tests individual sections such as diodes, triodes, pentodes, etc., in multi-purpose tubes.
- ★ Latest type voltage regulator.
- ★ Features an attractive etched aluminum panel.
- ★ Works on 90 to 125 volts 60 cycles A.C.

Model 1240 comes complete with instructions and tabular data for every known type of receiving tube. Shipping weight 12 pounds. Size 6" x 7 1/2" x 10 3/4". Our Net Price **\$11.85**  
Portable Cover \$1.00 Additional

## SUPERIOR INSTRUMENTS COMPANY

136 Liberty Street Dept. RC-12 New York, N. Y.

Please Say That You Saw It in RADIO-CRAFT





**RADIO'S No. 1**  
*Free Catalog*  
**COMPLETE UP-TO-DATE**  
*saves you money!*

If you're connected with radio or sound, this book can be of tremendous help. It's **BIG**—188 pages of receivers, xmitters, parts, tubes and supplies. All the nationally advertised names. It's **COMPLETE**—even has the hard-to-get items out of manufacture. It's **UP-TO-DATE**—includes a complete stock of television apparatus, Build-it-Yourself Kits, etc. You can't beat the quality—or the low prices. Speedy service. Mail the coupon below for your **FREE** copy of catalog No. 78 **TODAY**.



**AMAZING 7 tube Hi-Fi RECEIVER only \$9.95**

You build it yourself! In convenient Kit form, complete with instructions including pictorial, schematic and wiring layouts. TRF circuit used is similar to that found in this year's high priced receivers. Four of the seven tubes are single end type. Assembly simplified by grouping by-pass condensers within a single case. **R20359**—Complete Kit of parts less speaker, tubes and cabinet. (Add postage. Shpg. wgt. 6 lbs.) Own a high-fidelity receiver at the remarkably **\$9.95** low price of



*one minute!*

You will want our special **FREE** Christmas gift-catalog, too. This coupon brings both. Just double check and mail.

Radio Wire Television Inc. WHOLESALE RADIO SERVICE, INC.

**LAFAYETTE RADIO**

NEW YORK  
 100 SIXTH AVENUE  
 CHICAGO  
 901 W. JACKSON BLVD  
 ATLANTA  
 245 PEACHTREE STREET  
 BOSTON • BRONX  
 NEWARK • JAMAICA

Radio Wire Television Inc.  
 Dept. BM9-100 Sixth Ave., New York, N. Y.  
 Rush **FREE** 1940 Radio Catalog No. 78   
 Rush **FREE** Xmas Catalog No. 79

Name.....  
 Address.....  
 City.....State.....

**PASTE COUPON ON PENNY POSTCARD**

# THE LATEST RADIO EQUIPMENT

*These new radio products are so laid out that they may be conveniently referred-to when writing to manufacturers for additional information.*

## "EXAM-ETER" CIRCUIT-AND-COMPONENTS ANALYZER

Solar Mfg. Corp., Bayonne, N. J.



**H**ERE is an A.C.-operated laboratory and service instrument of remarkably wide usefulness. It quickly tells the quality story of components, is a troubleshooter and gives prompt answers to the questions of what will work best; this "Exam-eter" includes an "eye" tube for visual indications. Its functions include output indicator, dual-range peak voltmeter, R.F. circuit alignment indicator, condenser bridge, resistance bridge, electrolytic condenser power factor indicator, leakage indicator, and continuity tester. The peak voltmeter is provided with 2 ranges: 0-30 and 0-2,000 V. The condenser bridge has a range of from 10 mmf. to 1600 mf. Resistance bridge can measure from 50 ohms to 7.5 megs. The instrument operates on either 110 or 220 V. A.C., is in a cabinet measuring 10 3/4 x 12 x 9 1/4 ins., and weighs but 10 lbs.

December 1939 *Radio-Craft*

## LATEST-TYPE "BRIEFCASE" PORTABLE

Emerson Radio and Phonograph Corp.  
 111 Eighth Ave., New York, N. Y.

**W**ITH pardonable pride we refer you to the September 1936 issue of *Radio-Craft* in which we described what we believe to have been the *first* Briefcase Portable ever made. This year, however, this type of receiver is definitely the vogue. The Emerson model DC-308 is typical of this new style in radio. It's a 5-tube battery-operated superhet, using a complete complement of 1.4-V. tubes. Although it has a built-in loop antenna, provisions are made for using an external antenna when located too far for average reception.



December 1939 *Radio-Craft*

## TUBE AND BATTERY TESTER

Weston Electrical Instrument Corp., Newark, N. J.

**T**HIS tube and battery tester has been especially designed to service the thousands of battery-operated portables which are at the present time so popular. All batteries are tested under actual load requirements and their condition is read on a **GOOD-REPLACE** scale, with the "cut-off" point set at the proper value. Most important, however, the current drain on the battery is also adjusted to conform to the requirements of the set. For the battery circuit, 5 pin-jacks are provided, labeled for the different battery voltages encountered, viz., 1.5, 6, 45, and 90 V. The tube checker portion of the instrument will check all types of tubes including the very latest 117-V. filament type. In addition, the checker is equipped for opening the filament circuit and making tests on all ballast tubes including those with ballast resistor connections across the normal filament pins. A spare socket is provided on the instrument for possible future requirements. The instrument, known as the model 777, is available both in counter and portable types. Data is printed on a roller index system for quick location.



December 1939 *Radio-Craft*

(See page 360 for other new items)

Please Say That You Saw It in RADIO-CRAFT



## NOVEL P.A. INSTALLATION WINS 1st PRIZE IN CONTEST

(Continued from page 349)

The reason the mixer was kept separate from the amplifier was so that at any time in the future if it was necessary to install a larger amplifier the only change would be replacement of the amplifier itself. The volume control for the paging system was put in the mixer for the same reason. There is only one input to the amplifier itself—it is a standard, high-impedance input, so that practically any amplifier could be substituted as needed. The volume control for the radio and phonograph are on these units.

(10) The amplifier is a 40-watt job which is ample to take care of the present load, in fact the volume control is set at the half-way mark and the volume is sufficient all over the factory. The 4,000-ohm output is carried to a convenient point where it is split up and carried to the 22 permanent-magnet speakers.

(11) The P.M. loudspeakers are 10-inch units with good, heavy magnets set in 27-inch square baffles of plywood, the edges beveled and then the whole baffle stained. The idea of the flat baffle was to utilize both the front and back sound waves. The back of each loudspeaker was covered with the same cloth as was used for the grille in front. Each speaker has its own 500-ohm in voice coil transformer, the 500-ohm lines feeding separate parts of the building from the 4,000-ohm-to-500-ohm transformer. There are about 2,000 feet of speaker wiring in the building.

(12) The time clock was originally spring-wound, but was changed over to electric operation by installing a Telechron motor after removing the spring mechanism.

The work signal contacts were small silver contacts, mounted in the brass face of the clock for the hour contacts, and in a brass ring around the edge of the face for the minute contacts. Small, solid-silver wipers were attached to the hands of the clock. When both the hour and minute hands of the clock were in contact with studs it closed the circuit through a relay, which was mounted in the clock, and the relay contacts then operated the power relays.

The contacts on the clock hands only pass 5 ma. at 7.5 volts for a period of 15 seconds 8 times per day, which means that the dry-cells (7.5 volts) will last about as long as the shelf life of the cells. The locating of these contact studs was the only part that gave any trouble, and it took several hours to place the studs in the right place. As the studs were drilled and threaded into the clock face, holes HAD to be right the first time, and when it is remembered that the minute hand traveled 0.557-inch per minute, a difference in location of 1 stud by only 1/8-inch meant that there would be about 13 seconds' error. I had guaranteed accuracy to within 5 seconds total at all contacts, that meant 2 1/2 seconds either way!!! Duplicate contacts operate the master A.C. switch for all these units and the switchboard, but to avoid confusion are not shown. See Section A in Fig. 2, and Fig. 4.

In Fig. 1 the ringing relay operates by the A.C. ringing signal; its contacts then pass D.C. through the coil of the next relay (contacts A are in parallel). The holding relay stays closed as long as the caller keeps the receiver off the hook—after dialing No. 44; contacts B close the input of the amplifier. The copper slug was added to the D.C. relay to cause contacts B to close last so that no clicks would be heard over the amplifier's speaker.

In Fig. 2 are shown a number of details of the time-signal power relays, etc. All

(Continued on page 361)

# LEARN RADIO at HOME in SPARE TIME

The Complete Ghirardi Course in ONE Handy Volume TRAINS YOU QUICKLY for a good-paying job in Radio or Television

THOUSANDS HAVE STARTED SUCCESSFUL RADIO CAREERS FROM THIS ONE BIG BOOK

Your Big Chance—Take It!

NOW—at last—you can get your start in radio, you can prepare for a good-paying radio job, without expensive schooling or lengthy study. Here in one inexpensive volume is a complete radio education for you, —everything is illustrated and explained clearly—right from basic electrical theory up through television—36 different Chapter-Sections in all—36 separate self-instruction courses condensed into one easy-reading home-training book.

### AS EASY AS ABC

#### Use Ghirardi's Short-Cut Methods

It's absolutely amazing the way Ghirardi makes every phase of radio clear and simple to understand. No previous training is necessary—no "math." Yet when you finish the book you may have a better grasp of the subject than many so-called "experts." Even if you can devote only a few minutes a day to your training, you will be surprised and delighted at the rapid progress you make if you use this great book.

#### All You Need to Know About Radio Between These 2 Covers—

##### Basic Fundamentals — Practical Applications

Never before has it been possible to master the fundamentals of the whole science of Radio so easily, so quickly, so economically. Just imagine a book that really gives you a thorough grounding in every phase of this fascinating field! Take Electricity alone, for example—no textbook ever written will give you a clearer picture of electrical theory and principles. Ghirardi brings out his simple explanations with such vivid clarity you'll never be in doubt again the rest of your life. Radio theory and receiving are explained to you in full detail, but without one wasted word. Over five hundred diagrams, drawings and photos illustrate the graphic descriptions he gives you. This great book will give you the basic knowledge that is essential for landing any kind of a radio job—in broadcasting studios, in radio service organizations, in plants manufacturing radio equipment, etc., etc.

#### LEARN TELEVISION TOO!

Yes, this course gives you a solid background in Television fundamentals, SOUND, too, with all its different branches—Microphones, Public Address Sys., Sound Films, etc. You'll master the intricacies of Cathode-Ray Tubes and Photoelectric Cells as easily as if it were child's-play. And though all this knowledge is at your command, it is but a fraction of the book's contents! There's Testing and Servicing; Automobile and Aircraft Radio; Short-Wave Reception; and still that isn't all! Just to specialize in the scope of this gigantic home-study course, you'll really have to get the book and thumb through the pages at your leisure.

#### Get It All for Only \$4 Complete!

Believe it or not, this inexhaustible storehouse of radio knowledge is yours to own and use for the price of an ordinary hat! You would have to pay many times this price to cover the same ground in any other course—and even so you could never duplicate Ghirardi's "Radio Physics Course." Because this book is head and shoulders above all others, it is now used by more radio schools and world. Think of it for only \$4 you can get your practical radio training at home, the very same thousands of others have, who are today earning good money in a congenial ever-broadening career. Follow their example and seize this opportunity to get started with Ghirardi. Send for your copy now—without delay!



RADIO, TELEVISION ELECTRICITY, SOUND CATHODE-RAY TUBES, etc.

### 36 Volumes in 1

RADIO, ELECTRICITY and SOUND Complete Plus Many Other Valuable Special Features are Covered in These 36 Big Chapter-Sections. 972 Pages. 508 Schematic Diagrams, Charts and Photos. 856 Review Questions.

- |  |   |
|--|---|
| 1. Radio Broadcasting System.                            | 19. Construction of Vacuum Tubes.                       |
| 2. Sound, Speech and Music as Related to Broadcasting.   | 20. Vacuum Tube Detector and Amplifier Action.          |
| 3. Electron Theory. Electric Current.                    | 21. Radio Frequency Amplification.                      |
| 4. Electrical Units. Ohm's Law. Resistance.              | 22. Superheterodyne Receivers.                          |
| 5. Electrical Circuits. Batteries. The Broadcast System. | 23. Design of R.F. Amplifiers and Tuning Coils.         |
| 6. Magnetism.  | 24. Audio Amplification.                                |
| 7. Electromagnetism.                                     | 25. Loud Speakers.                                      |
| 8. Electromagnetic Induction.                            | 26. Battery Operated Receivers.                         |
| 9. Inductance and Inductors.                             | 27. Power Supply Units.                                 |
| 10. Capacitance and Condensers.                          | 28. Electric Receivers.                                 |
| 11. Alternating Current Circuits.                        | 29. Automobile and Aircraft Receivers.                  |
| 12. Electric Filters.                                    | 30. Phonograph Pickups and Sound Amplifier Systems.     |
| 13. Electrical Measuring Instruments.                    | 31. Short Wave Reception.                               |
| 14. Electromagnetic Radiations.                          | 32. Vacuum Tube Applications and Photoelectric Cells.   |
| 15. Radio Transmission, the Broadcasting System.         | 33. Television.   |
| 16. The Receiving Station. Detection with Crystals.      | 34. Antennas and Grounds.                               |
| 17. Elementary Study of the Vacuum Tube.                 | 35. Testing and Servicing.                              |
| 18. Vacuum Tube Characteristics.                         | 36. Sound Motion Pictures. Appendices (Charts, Tables). |

972 Pages

#### Use It 5 Days — OUR RISK!

You can't possibly lose—our Money-Back Guarantee protects you 100%. Read the book for 5 days. Then if you'd rather not keep it, send it back undamaged. Your money will be immediately refunded—no fuss—no trouble. Take us up on this offer. You owe that much to yourself. You have the ability. . . . Now get the training, and show the world what you can do. Take the first step right now—fill out and mail this coupon . . . AT ONCE!

#### MAIL COUPON TODAY

RADIO & TECHNICAL PUBL. CO., Dept. RC-129  
45 Astor Place, New York, N. Y.

Enclosed find \$4 (\$4.50 foreign) for my copy of Ghirardi's "RADIO PHYSICS COURSE," with your 5-day Money-Back Guarantee.

NAME .....

ADDRESS .....

CITY ..... STATE .....

Please send me free descriptive literature.

#### Get Started — RUSH COUPON NOW!

#### UNIVERSAL 5MM.

All purpose microphone including amateurs, P.A., schools, stage, etc. Beautiful in appearance. Small in size. Superior in performance. High fidelity reproduction voice and music. Incl. locking plug and 25 ft. cable. Direct to grid or any desired impedance. In De Luxe package at your jobbers now.

UNIVERSAL MICROPHONE CO., LTD.  
424 Warren Lane, Inglewood, Calif., U.S.A.



**FREE AMPLITONE**  
New 1939 Sound Catalog

The most complete Sound Line ever offered.

Get your FREE catalog today!  
**AMPLITONE PRODUCTS CO.**  
135 Liberty St. New York City, N. Y.

Please Say That You Saw It in RADIO-CRAFT



# GIFT MERCHANDISE for you SHOP EQUIPMENT for you when you sell

## NATIONAL UNION RADIO TUBES



### GENUINE FULLY EQUIPPED COLSON BICYCLES

● Boys' or Girls' Model . . .  
Retail Value . . . \$34.50

Double bar streamlined 18-in. frame, light tank with horn, luggage carrier, chain guard, Texas steer handlebars, New Departure coaster brake, balloon tires. Available also in girls' model with similar features . . . Immediate Delivery on Dealer Deposit of \$16.00

### FAMOUS MARLIN SHOTGUN



#### OVER-UNDER TYPE IN VARIETY OF GAUGES

● Retail Value . . . \$39.90  
● Available in 12-16-20 gauges and .410 bore. Perfectly balanced, easy handling, strongly built. Positive automatic safety . . . Approximate weight, 12-gauge, 7½ lbs., 16- and 20-gauge, 6¼ lbs., .410 bore, 5¼ lbs. Immediate Delivery on Dealer Deposit of \$22.50



### STURDY STEEL BRIDGE TABLE and CHAIRS

Retail Value . . . \$22.50

● Steelart Style "F" sets offer folding bridge furniture that the most exacting hostess will be proud to use. Rigid steel table and folding chairs with pinchproof hinges and no sharp corners to snag garments. Immediate Delivery on Dealer Deposit of \$8.00

### YOU CAN CASH IN TOO

What National Union is doing for others, it can do for you. Thousands of completed premium agreements prove the fairness of our proposition. Equipment or premium is obtained immediately on small deposit—no time payments to meet or exorbitant interest rates to pay. You get your deposit back as merchandise credit. Try it and see why it pays to buy your tubes and condensers the National Union Way.

RC-1239

Ask Your Jobber or Write

**NATIONAL UNION RADIO CORP.**  
57 STATE STREET, NEWARK, N. J.

## THE LATEST RADIO EQUIPMENT

(Continued from page 358)

### 2-VOLT STORAGE CELL AND CHARGER

Portable Electric Power, Inc.  
30 Rockefeller Plaza, New York, N. Y.

**E**XTREMELY compact in size and economical in operation, this chargeable 2-V. cell is an ideal power source for battery portables using the 2-V. tubes. Constructors also will find them a boon for shortwave receivers, broadcast portables, PE-cell equipment, etc. Known as the model PEP, the cell is non-spillable and leak-proof. The cell is available in 4 standard sizes which last 6, 15, 24 and 36 hrs., respectively, provided the drain is not more than ¼-ampere. Their dimensions vary from 3-1/16 by 1-1/16 by 2½ ins. high for the smallest size (8 ozs.) to 2⅞ x 2¼ x 3¾ ins. high for the largest size (2½ lbs.). The tube-type chargers are available in either 110 V. A.C. or 110 V. D.C.



December 1939 Radio-Craft

### LATEST 5-IN. OSCILLOSCOPE

RCA Parts Division, RCA Mfg. Co., Inc., Camden, N. J.



**T**HIS new 5-in. cathode-ray oscilloscope may be used for a wide variety of experimental and test applications in school and industrial laboratories as well as in the radio service shop. Embodying all the latest advances in technical design the oscilloscope is equipped with amplifiers of unusually wide ranges and has a horizontal sweep voltage range from 4 to 22,000 cycles. The 5-in. tube provides a large, well-defined trace for accurate analysis purposes. The instrument is housed in a portable light-weight cabinet with all controls conveniently located on the front panel.

December 1939 Radio-Craft

### GENERAL UTILITY METER

Radio City Products Co.  
88 Park Place, New York, N. Y.

**T**HIS is an A.C.-D.C. instrument in which a 1-ma. d'Arsonval-movement meter with a guaranteed accuracy within 2% is utilized to provide a variety of current, voltage and resistance measurements. Sixteen ranges in all are provided. Voltage ranges, both A.C. and D.C. are: 0-5-50-500 and 1,000. Resistance ranges include 0-5,000 and 0-500,000 ohms. Current ranges are 0-1 and 0-10 milliamperes. As a decibel meter, 4 ranges are provided as follows: -12 to +8, +8, to +28, +28 to +48 and +34 to +54. The instrument shown is the model 456 and is contained in a finely-finished hardwood case with self-contained batteries for the resistance measurements.



December 1939 Radio-Craft

### HIGH-VOLTAGE TUBULAR PAPER CONDENSERS

Cornell-Dubilier Electric Corp.  
South Plainfield, N. J.

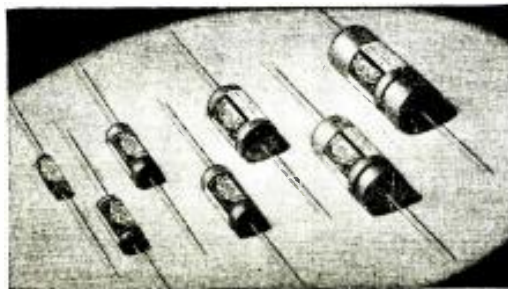

**W**ITH rated working voltages up to 1,000 V. these new type MD tubular condensers meet substantially all requirements of television receivers, test equipment, and amateur transmitter applications in which high voltages are used. They are available in a wide variety of capacity values ranging from 0.0001- to 0.15-mf. at 800 V.; 0.001- to 0.1-mf. at 1,200 V.; and 0.001- to 0.05-mf. at 1,600 V. The condensers are thoroughly impregnated with what the manufacturers call "Dykanol D" and are

finally hermetically sealed in a card-board tube. All the units use pigtailed for making connections.

December 1939 Radio-Craft

(Turn to page 362 for other new items)

Please Say That You Saw It in RADIO-CRAFT



## NOVEL P.A. INSTALLATION WINS 1st PRIZE IN CONTEST

(Continued from page 359)

A.C. lines including the switchboard power supply are fed through a master A.C. switch which is operated "ON" at 7:15 A.M. and "OFF" at 5:30 P.M. on weekdays, by another relay tied-in to the clock circuit. This master switch is in parallel to a hand-operated switch for use at other times than the above. This equipment is not shown as it is not a part of the P.A. installation, even though it was installed at the same time.

Referring to Fig. 5, note that each of the 22 loudspeakers has a 500-ohm-to-voice coil transformer. The 4,000-ohm line is worked into several 500-ohm transformers, as previously described.

### CHOICE OF EQUIPMENT AND REASON FOR USE

(1) The use of the telephone transmitters as microphones was considerable improvement over using the conventional, 2-way system on account of the great amount of noise in the factory, and it was also a novel (and to me an untried) method. As there were, or could be installed, a telephone at every vital spot in the factory it seemed an excellent idea, and has worked out remarkably well.

(2) The use of the telephone transmitters necessitated some sort of a device to connect the telephone system to the amplifier input, keep it connected at the will of the caller, and restore to normal upon completion of the call; also, to throw a "busy" to any other line that called 44 while it was in use. Figure 5 shows the only way I could figure to do it.

(3) The amplifier was picked to stand up under constant daily use without breakdown, and runs 10 or more hours every day that the factory is open. The mixer was kept separate so that in the event of breakdown I could substitute most any amplifier of sufficient rating. The amplifier output was changed to 4,000 ohms as I have about 25 amplifiers in use as rentals, all with 4,000-ohm outputs, and in the event of breakdown I would use one of my rentals as a spare. While the present amplifier is large enough, in case a larger one is ever needed, it can be changed in a few minutes.

(4) The speakers are 10-inch P.M.'s of a very fine make, and as I have used the same manufacturer's speakers for many years in everything from the 6- to the 18-inch models without any trouble, I used them on this job.

(5) The output transformer and the speaker transformers were made by a national advertiser and bought from the same distributor as the amplifier.

(6) The parts for the oscillator were in stock, except the batteries.

(7) The relays were made as needed in our shop.

(8) The radio set was picked for dependability, and because it was compact.

(9) The automatic record changer too was selected for dependability, and because it takes as small a space as any on the market.

(10) As the oldest sound man in this part of the country, and having been associated with "radio" since the days of the coherers and de-coherers (I had a "wireless" transmitter in 1910) I have learned by experience what and where to buy any items of radio or sound equipment. The items picked for this job were the best, to the best of my knowledge and belief. More expensive parts might have been bought, but I am sure they would not have functioned any

(Continued on page 370)

# 5 Radio Books in 1

Free

## THE CATALOG WITH EVERYTHING IN RADIO!



New Knight sets for every purpose, 4 to 12 tubes, newest features, "Air Magnet", Gemloid Dials, etc.—latest portables, 1-tube electric phonographs, 5, 7, 11-tube phono-radios, complete phono accessories,—all sensational values!



Now, "Economy", "Standard" and "Do luxe" lines—14 new systems, 6 to 70 watts, new beauty, utility and performance!—new "mikes", latest recording equipment, all at lowest prices. Investigate ALLIED's New low-cost Time Payment Plan!

Most complete amateur listing in all radio—all latest receivers, Skyriider "Defiant", etc., Rotary Beam, Television equipment, all standard lines at lowest prices—and a New low-cost Time Payment Plan!

15,000 Radio items with parts for every purpose, tubes for all radios, latest books, tools, etc., at lowest prices! Complete Test Equipment, Rider Voltohmyst, etc. Dozens of new kits, diagrams and projects! Free Parts Lists.

Special 8-page section of the country's biggest radio bargains! Smashing values in BRAND NEW standard radio parts, cabinets, headphones, and miscellaneous accessories. Don't miss these super-values!

Thousands of radlomen find ALLIED's 204 page radio catalog the answer to the problem of "where to buy at lowest cost." For, whatever you need is always in ALLIED's catalog at lowest prices! Get your FREE copy TODAY!

**DEALERS SAY:** "The new Knight Sets are a group. Those remarkably low prices can't be beat! Your catalog is invaluable for supplies of all kinds!"

**SERVICEMEN SAY:** "Your 1940 catalog is the best ever! Bigger listings than ever before, with all the repair parts for every Service requirement!"

**P. A. MEN SAY:** "Thanks for the complete range of great new P. A. systems. Your 'Choice of 3 Systems' serves every P. A. purpose!"

**AMATEURS SAY:** "That big new Ham Section takes the prize! The full dope on all the newest gear and everything a Ham might want! Thanks for a real catalog!"

**BUILDERS SAY:** "You sure know what a Builder wants! More kits, diagrams and projects than ever before in your 1940 Catalog. It's a honey!"

### Mail this Coupon

ALLIED Radio Corporation  
Dept. 2-M-O, 833 W. Jackson Blvd.  
Chicago, Illinois

RUSH me your FREE 204-page Radio Catalog.

Name .....

Address .....

City ..... State .....

# ALLIED RADIO CORPORATION

833 W. JACKSON BLVD. CHICAGO

### GET A BEAUTIFUL DESK LAMP ABSOLUTELY FREE!

Complete details as to how it is possible to get a Beautiful Desk Lamp FREE, appear on Page 378 of this issue. TURN TO IT NOW!

Examine **SOLAR**

# EXAM-ETER

CIRCUIT and COMPONENTS ANALYZER  
including PEAK VOLTMETER

A sensational! Combines more important test functions than ever offered before for only...

## \$39.00

YOUR COST

Write for full details

**SOLAR MFG. CORP. Bayonne, N. J.**

## NEW TURNER DYNAMIC

MODEL 33D  
Removable 25 Ft. Cable Set-Tilting Head  
\$25.00 200 or 500 ohms or hi-impedance  
Deduct \$1.50 for 50 ohm model

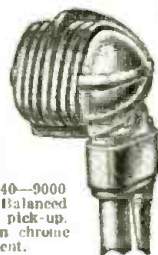

TROUBLE-FREE operation for recording or P. A. work. Ideal for the ham. Output—54DB. Smooth response 40—0000 cycles. Free from feedback. Balanced line cable eliminates noise pick-up. Engineering style, full satin chrome finish adds class to equipment.

WRITE FOR DETAILS  
**The TURNER CO.**  
907 17th St., N. E.  
CEDAR RAPIDS, IOWA

Dependable Results at Low Cost!

Please Say That You Saw It in RADIO-CRAFT



THE LATEST RADIO EQUIPMENT

(Continued from page 360)

MY FREE BOOK SHOWS HOW  
**YOU CAN BECOME A MONEY-MAKING RADIO EXPERT!**  
with my New  
**SPRAYBERRY Personalized HOME TRAINING in RADIO AND TELEVISION**  
**EASY TO START... EARN WHILE YOU LEARN**  
I Train You Quickly in Your Spare Hours Right at Home

You Do Practical Experiments with Real Equipment  
I offer you a new and altogether different type of practical training for a money-making career in Radio and Television. I teach you in a simplified, logical, understandable style... all about Television, Electronics, Facsimile Radio, Radio Set Repair and Installation. I GIVE YOU PERSONAL COACHING ALL THE WAY.

**TRAINING PREPARES YOU FOR GOOD RADIO JOBS . . . at Excellent Pay**  
No matter if you desire to BE YOUR OWN BOSS in your own business or hold down a good job in Radio, my Training will give you the useful information and knowledge to win success. DON'T JUST WISH FOR MORE MONEY—START TRAINING FOR IT RIGHT NOW.

Read What This Student Says:  
**EARNED \$250 SINCE STARTING COURSE**  
"I have only completed one-third of the Sprayberry course and I find it very interesting, which makes it easy to learn."  
"By devoting several hours of my spare time daily to studying and servicing, I have made about \$250 gross since starting the course." Earl W. Hostetter, R. No. 4, Lebanon, Pa.

**YOU GET PROFESSIONAL TEST EQUIPMENT PLUS EXPERIMENTAL OUTFITS**



Includes 146 RADIO PARTS for building a complete 5-tube Radio Receiver, RADIO TOOLS, ALL-WAVE, ALL-PURPOSE ANALYZER. Besides its invaluable use in experimental work, my Equipment will enable you to make spare time profits while you're learning and can serve you in your own Service business later on. I give you DATA SHEETS on how to build popular Radio circuits. Also you receive BUSINESS BUILDERS which show you how to get and do spare time, neighborhood Radio Service work.

**NO PREVIOUS EXPERIENCE NEEDED**  
My Training starts right at the beginning of Radio. It covers all essential subjects. It makes no difference what your education has been. I can fit you for an excellent paying job in Radio. Your success is my full responsibility. I know how to get Radio across so that you will understand it and remember it.

**SERVICEMEN**  
I offer Advanced Training for those already in Radio. Get complete details in my FREE 52-page Book.  
**REMEMBER—THE SPRAYBERRY COURSE IS SOLD UNDER A MONEY-BACK AGREEMENT**

**RUSH THIS COUPON FOR BIG FREE BOOK**

**DON'T DELAY! ACT NOW!**  
SPRAYBERRY ACADEMY OF RADIO  
F. L. Sprayberry, Pres.,  
220-M University Place, N.W., Washington, D.C.  
Please send me FREE copy of "HOW TO MAKE MONEY IN RADIO."  
Name ..... Age .....  
Address .....  
City ..... State .....  
Tear off this coupon, mail in envelope or paste on penny postcard. Servicemen—Check here

PORTABLE INTERFERENCE LOCATOR

Sprague Products Co., North Adams, Mass.



THIS instrument has been specifically designed for locating sources of man-made radio interference. It consists of a portable, battery-operated, sensitive R.F. amplifier, an A.F. amplifier, and a loudspeaker; a highly-directional, self-contained loop antenna, and a fish-pole antenna; and output meter and phone jacks. The combination of loop and telescoping-pole antenna is provided to allow the determination of both direction and height of interference sources. The receiving unit has an average sensitivity of 40 microvolts for a 50-milliwatt output over the entire broadcast range. By means of a switch the interference locator is convertible into a regular portable radio receiver, thus permitting demonstration to the customer of the actual reduction of noise level achieved by corrective measures. The receiver tunes over the complete broadcast range of 500 to 1,600 kc.; and is housed in one of the new briefcase-type cases.

December 1939 Radio-Craft



TILTING-HEAD CRYSTAL MICROPHONE

The Turner Co., Cedar Rapids, Iowa

KNOWN as the model 22X this crystal microphone is provided with a tilting head adjustable over a 90-degree range for semi- and non-directional pick-up. The design of the microphone head is such as to allow the cable set to be removed and changed without opening the mike. It has a range of from 30 to 7,000 cycles; and an output of -52 db. The microphone, says the manufacturer, is fully shielded and protected for the ham rig, yet rugged enough for the toughest P.A. job. This microphone was designed by Arthur Charles Haggstrom, stylist for the Jensen Radio Mfg. Co., the Jefferson Electric Co., and other well-known style leaders. The new microphone is satin-chrome-plated all over, in streamline, modernistic design.

December 1939 Radio-Craft

ALL-PURPOSE APPLIANCE TESTER

The Hickok Electrical Instrument Co.  
10514 Dupont Ave., Cleveland, Ohio

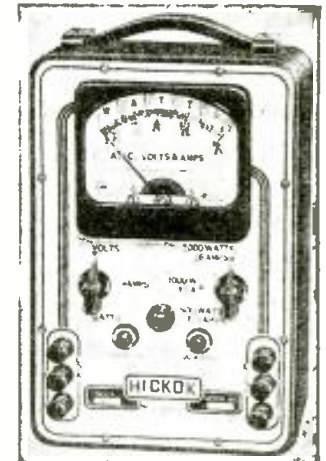

THIS new tester has 10 ranges of A.C. volts, amperes and watts. While it is designed primarily for electrical appliance testing, it is also useful for radio, as the wattmeter checks A.C. sets. Known as the model 900, this instrument is especially valuable for A.C. troubleshooting since it tests appliances while in actual operation, indicating power consumption, current flow and line voltage. It has 4 ranges of power, up to 2,000 W., 4 ranges of current to 26 amperes, and 2 ranges of volts, 0-130-260. A Dynamometer-type meter with a specially-designed current transformer is employed with suitable switching to obtain all these ranges. The instrument is available for both 60- and 25-cycle operation.

December 1939 Radio-Craft

NEW 14-WATT AMPLIFIER

Thordarson Electric Mfg. Co.  
500 W. Huron St., Chicago, Ill.



THIS NEW 14-W. amplifier features a beautiful steel cabinet, modern in appearance and sturdily constructed. A multiple-stage "inverse feedback" circuit and low-frequency "booster" provide linear response to 15,000 c.p.s. with the addition of accentuated bass. This unit was designed for high-fidelity amplification of speech and music, and reproduction is claimed to be surprisingly natural.

December 1939 Radio-Craft

(Turn to page 364 for other new items)

Please Say That You Saw It in RADIO-CRAFT



## FOR BEGINNERS— A PENTODE POCKET SET

(Continued from page 344)

antenna as you can possibly install. A hank of antenna wire about 50 ft. long is recommended if you intend to use the receiver out-of-doors. However, if you use this portable set on a bicycle or in a car, a 6- or 7-foot bumper pole antenna may be employed; this of course limits reception to the more powerful stations.

### CHECKING-UP

After you have completed the set, you may possibly experience some difficulty in obtaining the type of performance of which the set is capable. Of course, if the set does not operate correctly, it is wise to check the entire circuit. Occasionally, however, you will find that the difficulty can be located by making the following tests:

If you do not obtain oscillation when the regenerative control is advanced, you may possibly have connected the tickler coil backwards. Reverse the connections to this coil and repeat the test.

Connection of the "A" cell can be checked by noting whether the filament of the tube glows faintly.

When you touch the control-grid of the tube you should hear a click and a continuous buzzing in the headphones. Otherwise, check the plate-tickler-headphone circuit.

Because this 1-tube Pentode Pocket Receiver is so compact, you can take it practically anywhere. As has been mentioned, you can install the set on a bicycle. Other possibilities are these: take it along when you go to the ball games and football games, and both look at the games and listen to the games as they are being broadcast; take the set with you when you go hiking or boating; use it at picnics and outings. In short, the Pentode Pocket Set is a portable which will give you a world of pleasure, at very small cost. Be the first in your crowd to have one.

### LIST OF PARTS

- One octal socket, wafer type;
- One antenna coil, unshielded;
- One extra primary winding, used as tickler;
- One metal cabinet, and assembly screws;
- Two pointer knobs;
- One antenna binding post;
- Two insulated tip-jacks;
- One midget control (with switch), 50,000 ohms;
- One grid cap;
- One Raytheon type 1H5G tube;
- One flashlight-type, 1½-V. cell;
- One midget battery, 45 V.;
- Two mica condensers, 250 mmf.;
- One resistor, 2 meg.;
- One 3-position switch;
- One Yaxley plate, numbered 1 to 3;
- One padder, 25-100 mmf.;
- One padder, 75-225 mmf.;
- One padder, 175-500 mmf.;
- One hardware kit, consisting of: 1 roll of hookup wire, 10 ft.; 2 brass bushings; 3 6/32 x ¾ in. screws; 4 6/32 nuts.

This article has been prepared from data supplied by courtesy of Allied Radio Corp.

According to an issue of *Radio Daily* West Chester State Teachers College is using radio to advertise the school in preference to direct-mail advertising. Phono recordings made by the class fall into the "public service" group and are broadcast by various stations, to which they are mailed, in Pa., N. J., Del. and Md.

# SERVICEMEN WHO KNOW—PREFER

*Readrite*  
TESTER **RANGER** METERS

## MODEL 432-A

- MODEL 432-A is the outstanding tube tester value for tubes of today and tomorrow. Has RED•DOT Lifetime Guaranteed Triplett Instrument with Two Highest Quality Sapphire Jewel Bearings . . . Sockets for All Tubes . . . Filament Voltages from 1 to 110—A Safeguard Against Obsolescence . . . Separate Line Control Meter . . . Neon Shorts Test . . . Etched Panel of Outstanding New Design . . . Approved RMA Circuit.

This tube tester checks Loctals, Single Ends, Bantam Jr., Gas-tous Rectifiers, the New High

with  
**RED-DOT**  
Lifetime  
Guaranteed Instrument

**\$17.85 net**

Voltage Series (including 117Z6G) and others recently announced. Also has Ballast Tube Continuity Test, Direct Reading GOOD-BAD Meter Scale. Will not deactivate 1,4 volt or other type tubes. Furnished in Rich Black Leatherette Covered Portable Case—Professional in Appearance.

## POCKET VOLT-OHM- MILLIAMMETER

- With Selector Switch . . . Molded Case . . . RED•DOT Guaranteed 3-Inch Meter with 2 Genuine Sapphire Jewel Bearings. AC and DC Volts 0-15-150-750-1500; DC MA. 0-1.5-15-150; High and Low Ohm scales . . . Dealer Net . . . \$9.90.

## MODEL 739

For More Information Write:  
Section 1216 College Dr.



# READRITE METER WORKS

BLUFFTON, OHIO

## GET THIS FREE BOOK!

Only a few copies of the RADIO REFERENCE ANNUAL are still available! It's the BIG, FREE BOOK of 64 pages you receive when you subscribe to RADIO-CRAFT. The ANNUAL covers set building, servicing, public address, test equipment, plus a number of other interesting topics. Send your remittance of One Dollar to RADIO-CRAFT, 99-R HUDSON STREET, New York, N. Y., and you will receive a subscription to RADIO-CRAFT for Seven Months, and your copy of the RADIO REFERENCE ANNUAL will be mailed postpaid immediately.

IT'S LIKE HAVING  
YOUR OWN BROADCASTING  
STATION



## MYSTIC MIKE WIRELESS Outfit

It's taking America by storm! This perfected Mystic Mike Wireless Outfit, with variable frequency control, enables you to do your own broadcasting from any part of your home, office, or store WITHOUT the use of interconnecting wires. NO WIRES CONNECTED TO RADIO. Simply plug this unit into any AC or DC electric socket, speak or play into the microphone, and the speech or music will be picked up by ANY radio ANYWHERE in the same building. Has hundreds of uses, for entertaining, auditions, rehearsals, public address systems.

WRITE FOR FREE BULLETIN RC-12 MONEY BACK GUARANTEE  
OLSON MFG. CO., 362 Wooster Ave., Akron, Ohio

COMPLETE SET, WITH  
MICROPHONE and TUBE.  
**\$3.95**  
NET PRICE

Tear out this ad. write name and address in the margin. mail \$3.95 or order C.O.D. and we will send outfit at once.

Please Say That You Saw It in RADIO-CRAFT



THE LATEST RADIO EQUIPMENT

(Continued from page 362)



MODEL 2000 \$19.34 net

- 130 and 260 Volt Ranges—750 and 1500 Watts
- Current Rating 7.5 Amperes
- Reads Line Voltage and Wattage Simultaneously. Toggle Switch Protects Wattmeter During Starting Period.
- Light and Compact; In Portable Case.

Model 2000 is a handy portable tester combining a Triplett Wattmeter and Voltmeter in leather case. Ideal for field use in servicing radios, refrigerators, fractional H.P. motors and all types of household appliances.

No fussy connections to make. Just plug the tester into an outlet and the load into the tester receptacle. Read Watts on one side of twin meter and line volts on the other. Available in other ranges at slightly higher prices.



This Volt-Ohm-Milliammeter is a complete pocket-size tester with AC-DC voltage ranges: 0-10-50-250-1000-5000 at 1000 ohms per volt; DC Milliamperes 0-10-100-500; High and Low Ohms Scales. With RED DOT Lifetime Guaranteed Measuring Instrument Dealer Net \$14.50

WRITE FOR CATALOG!

The Triplett Electrical Instrument Co. Section 1612, Harmon Avenue, Bluffton, Ohio



CARRYING CASES FOR RECORDS

Chicago Sound Systems Co., 200 East Illinois St., Chicago, Ill.

THESE cases were made of 20 gauge steel, reinforced throughout. All seams are electrically welded. Full-length piano hinges are used on the door and top. The top locks down with patented quick-way, slip-proof clips. The interior is fully lined for record protection. Finished in black crackle enamel baked-on for durability and service. Model RC-1 is 10½ x 10¾ x 6¼ ins. wide; net weight, 4 lbs., empty. Model RC-3 is 10½ x 10¾ x 9¼ ins. wide; net weight, 5 lbs.

December 1939 Radio-Craft

20,000 OHMS/VOLT "UNIMETER" HAS TELEVISION-TEST RANGES

The Clough-Brengle Co., 5501 Broadway, Chicago, Ill.

THIS instrument has been designed to cover not only the common applications of industrial and radio usage but the higher voltages now current and anticipated in television receivers. Inasmuch as television voltages are in the order of 5 to 10,000 V., safety to the operator of this instrument has been a paramount factor in its design. Special high-voltage terminals (3,500, 7,000 V. A.C.; 5,000, 10,000 V. D.C.) are provided. Special polarized jumbo test prods are also provided for use with these ranges. Ordinary test leads cannot accidentally be used on the high-voltage ranges. The complete ranges of this instrument are as follows: D.C. volts: 0-5-20-500-1,000-5,000-10,000 (sensitivity, 20,000 ohms/volt). A.C. volts: 0-3.5-7-35-140-700-3,500-7,000 (sensitivity, 7,000 ohms/volt; reads to 0.25-V.). Output A.C.: same as A.C. volts. Decibels: -16+6, -10+12, -4+26, -16+38, +30+42 (6 mw., 500-ohm level). Direct current: 0-50-500 micro-amps., 0-5-50-500 milliamps., 0-5-20 amps. Resistance: 0-3,000-30,000 ohms. 0-3-30 megohms; scale center: 27, 270, 27,000 ohms, 0.27-megohm (Reads to ½-ohm.).



December 1939 Radio-Craft

How to Add 1 to 14 Modern Features to the ALL-PUSH-PULL DIRECT-COUPLED 30-WATT P.A. AMPLIFIER

(Continued from page 343)

frequency, regardless of what instrument is being played. Each tone's quality, however, is determined by the quantity and amplitude of its associated harmonics. If these harmonics are to be changed in intensity, a characteristic change takes place in the quality of the tone. Therefore, if any tone is amplified and its associated harmonics are altered in relation to the fundamental, a change in character of tone is to be expected. This accounts for the popular expression of "false bass," which is pronouncedly present in the usual bass-boosting circuits. This same condition exists when low frequencies are cut or when high frequencies are accentuated or attenuated.

Figure 2B. A typical response curve of an Audio Spectrum Control Circuit, Fig. 2B, shows how the fundamental frequency and its associated harmonics are equally accentuated, thereby introducing no change in the relative amount of harmonics present in the original signal. The Audio Spectrum circuit operates similarly in both the high- and middle-frequency bands.

Figure 2C. As this circuit employs a type of triode which has been carefully selected for minimum even-order harmonic contributions push-pull operation is not required. The circuit for the complete Audio Spectrum Control is illustrated in Fig. 2C.

CALIBRATED VOLUME INDICATOR

The use of a calibrated volume indicator across the output of the amplifier is a highly desirable auxiliary feature, for it enables an accurate check on the power

output delivered by the amplifier. The important point in constructing a volume indicator is to check the accuracy of indication over all audio frequencies. Any good 0-1 ma. meter utilizing an external copper-oxide rectifier may be employed with excellent results. As most copper-oxide rectifiers are comparatively inefficient at the higher frequency, a compensating network is required.

Because of the wide variations in both meter and rectifier construction, it would be difficult to offer a fixed method of compensation. However, a general procedure for adjustment will enable the average experimenter to obtain satisfactory results.

Figure 3A. In Fig. 3A is illustrated the basic copper-oxide rectifier arrangement. This arrangement, however, will usually fall off at the high frequencies. If R1 is selected to obtain a desired voltage at 1,000 cycles, and a potentiometer substituted in its place, compensation can easily be attained by utilizing a suitable condenser across the center arm and one end of the potentiometer.

Figure 3B. The most rapid procedure would be to introduce a condenser decade box at point CX, Fig. 3B, and adjust both the capacity of the condenser, and the setting of R1 until a flat response is maintained out to the highest frequencies to be measured. During these adjustments, constant references should be made to 1,000 cycles. Under any condition, the compensating network should not change the 1,000-

(Continued on page 368)

Please Say That You Saw It in RADIO-CRAFT



### LOCAL SERVICE SHOP CAPITALIZES ON ELECTRONIC ORCHESTRA

(Continued from page 345)

preamplifier is seen on the floor immediately to the left of the trumpet player.

A number of unusual, but quite simple technical features were included in this installation.

The mixer-preamplifier, with an overall gain of 55 db., in conjunction with any high-impedance microphone will provide sufficient input to the organ preamplifier to drive the organ to full output. The mixer-preamplifier described below was finally designed after trying several types of A.C. jobs with power transformer supplies but which involved hum difficulties. The circuit of Fig. 1, using an A.C.-D.C. type arrangement with 6C5 triodes throughout, provides humless operation comparable to a completely battery-operated preamplifier. Of particular interest is the inter-circuit common ground through the 1 mf. paper condenser, whereas all the input and output grounds are to the chassis proper. All input jacks are of the circuit-closing (grounding) type so that if any input circuit is removed no open grid will result.

The guitar input circuit on the mixer-preamplifier appears to have no control; however, a volume control is an integral part of the guitar which allows control of this instrument and proper mixing with the mic.

The complete circuit details of the Hammond organ are not necessary inasmuch as the preamplifier in the organ console proper has an easily accessible 200-ohm input which is shorted out when not in use. This input is on the terminal strip enclosed by the insulated metal cover. (Note: Do not confuse this preamplifier with the one being described. This is part of the original organ and drives the main organ amplifier located in the loudspeaker housing. Do not tamper with this unit in any way other than the input mentioned.)

A separate jack is installed in the regular guitar amplifier in parallel with one of the input jacks, for feeding the mixer preamplifier. The block diagram, page 345, shows the exact manner of inter-connecting the completed units. If the regular guitar amplifier is not to be used the guitar may be plugged directly into the mixer-preamplifier.

S. LEIBOWITZ, E.E.,  
Sound Division,  
Olson Brothers Radio Supply,  
Akron Ohio.

Referring to diagram, note that all inter-connecting cables are made with standard xtal mic. cable. All plugs are of shielded type. All transformers and chokes are of shielded variety. Use metal chassis and well-shielded components. Jack A.J. is an auxiliary jack for feeding the mixer-preamplifier; jacks J are regular input jacks on the guitar amplifier. *Radio-Craft* readers are invited to submit inquiries on electronic music installations to the author; be sure to enclose a stamped and return-addressed envelope.—Editor

#### RCA MODELS 6T AND 6K

**Circuit Change.** Resistor R15, a 0.063-ohm, flexible-type unit, in series with one side of the heater supply, has been removed from the circuit and the blue lead from the transformer is connected directly to the heater contact on the 6F6 output tube socket. The same change should be made on all receivers requiring field service.



NEW  
SUPER  
PRO

FULL RANGE "Selectivity"  
Single signal to HIGH FIDELITY

HIGH SENSITIVITY in a communications receiver is only usable when the proper degree of selectivity is also available. If selectivity is not sufficient, no amount of sensitivity will permit satisfactory reception. Here, the new Series 200 "Super-Pro" stands supreme. The extremely high sensitivity available in the "Super-Pro" is always usable because of the continuously variable selectivity characteristics. The I.F. band width control varies the selectivity from approximately 3 kc. to 16 kc.; in addition to this feature, the variable selectivity crystal filter permits the selectivity to be varied from 2½ kc. down to better than 100 cycles. The operator can adjust the selectivity of the new "Super-Pro" to a point where interference is reduced sufficiently to permit reception of the desired signal. This optimum point of selectivity permits the greatest possible fidelity without interference. The selectivity of the I.F. amplifier in the new "Super-Pro" is varied by mechanically changing the coupling between the primary and secondary of the I.F. transformers. This method provides a smooth control of selectivity.

In addition to the above features, the operator of a "Super-Pro" has available such other refinements as: noise limiter; continuous band spread; an AVC system designed for greatest effectiveness; a new adjustable "S-Meter"; two stages of tuned radio frequency amplification which practically eliminate images, and many others. If you want the best, get a "Super-Pro".



WRITE FOR FOLDER RC-12

424-438 WEST 33 STREET, NEW YORK CITY



# HAMMARLUND

Canadian Office: 41 West Ave., No. Hamilton, Ont.

#### A NEW BOOK ON PUBLIC ADDRESS

An important announcement about the greatest book on the subject of sound and allied subjects appears on Page 382 of this issue. **TURN TO THE ANNOUNCEMENT NOW!**



#### ALL YOUR RADIO NEEDS

Here in this one big book you will find everything you need in radio... sets, parts and supplies... public address systems... amateur equipment... testers and kits... your nationally known favorites at lowest possible prices. Write today for this big valuable catalog and save money.

FREE CATALOG

PROMPT SERVICE

**BURSTEIN-APPLEBEE COMPANY**  
1012-14 MCGEE STREET, KANSAS CITY, MISSOURI

Now!  
**BALLAST REPLACEMENT**  
made **AMAZINGLY SIMPLE!**

Only 4 standard types of Amperite AC-DC Regulators will replace 90% (over 100 types) of AC-DC Ballast Tubes now in use!  
**WRITE FOR CHART AR.**  
New Low Price \$1.00 List

**AMPERITE** 561 BROADWAY, N. Y.  
**AMPERITE** AUTOMATIC REGULATORS

Please Say That You Saw It in RADIO-CRAFT



# DIRECT-COUPLED AMPLIFIERS

Designed by A. C. Shaney



These new 10, 20 and 30 Watt Direct-Coupled (Push-Pull Loftin-White) Amplifiers are now available with any one or more of 14 optional features, including Variable Speed, Non-Overloading Push-Pull Expander, High Frequency Accentuation and Attenuation, Low Frequency Boost and Cut Control, Push-Pull Automatic Volume Compressor, Push-Pull Automatic Volume Limiter, Push-Pull Automatic Volume Control, Non-Frequency Discriminating Scratch Suppressor, Low-Gain Single Ended Input, High-Gain Single Ended Input, Low-Gain Push-Pull Input, High-Gain Push-Pull Input, Audio Spectrum Control, Calibrated Volume Indicator, and Push-Pull Remote Control.

Write or Wire Today for Complete Details and Unusually Attractive Prices.

**AMPLIFIER CO. of AMERICA**

17 WEST 20th STREET NEW YORK, N. Y.

● EASY—SIMPLIFIED—PRACTICAL ●

## ELEMENTARY MATHEMATICS

A book for the Technician and Craftsman, explaining and answering every meaning with illustrations. A real study-course in mathematics for the student or the man who wants to brush-up on his knowledge.

Special Chapter on Radio problems calculation.

### CONTENTS OF BOOK

I. ARITHMETIC: Addition, Multiplication, Division. II. Factoring and Cancellation, Fractions, Decimals, Percentages, Ratio, and Proportions. III. The Metric System. IV. How to Measure Surfaces and Capacity (Geometry). V. POWERS: Evolution—ROOTS: Evolution. VI. Mathematics for the Manual and Technical Craftsman. Thermometer Conversions, Graphs or Curve-Plotting, Logarithms, Use of the Slide-Rule. VII. Special Mathematics for the Radio Technician. VIII. Commercial Calculations. Short-cut Arithmetic, Interest, Discounts. IX. Weights and Measures. Useful Tables.

Stamps, Cash or Money Order

**TECHNIFAX**

Division RC-1239

1917 S. State St.

Chicago, Ill.

ONLY  
**50c**  
POSTPAID

## NEW CONDENSER ANALYZER —THRIFTY SERVICE TOOL

(Continued from page 334)

correcting. That is to say, pressure on any button will release all other buttons in the same bank or an entire bank can be cleared by partially depressing any one of its buttons. In the bank consisting of buttons 1, 2 and 3, two can be placed in the "in" position at one time by depressing them simultaneously. Both can be released by slight pressure on the third, or either one can be released by additional pressure on the other. In the lower bank it is never necessary to have more than one button "in" at one time. When any button is pressed it automatically releases any other that may have been down.

Thus it is seen that an amazingly intricate switching process has been reduced to the utmost simplicity. To further the simplicity of operation all readings of capacity values are made from the direct capacity calibrations carried on the large center scale. These calibrations appear in 6 ranges as follows (all in mf.): 0.00001 - 0.0012, 0.001 - 0.012, 0.01 - 0.12, 0.1 - 1.2, 1.0 - 24., and 20 - 240. Power factor readings from 0 to 50 per cent are also read directly from the percentage scale over which the power factor adjustment knob moves.

### WIEN BRIDGE

Capacity and power-factor measurements are made on the \*Wien Bridge arrangement shown in the upper left-hand corner of Fig. 1.

The different arms values are selected by the B and C sections of the switches controlled by pushbuttons 5, 6, 7, 8, 9 and 10. These, of course, correspond to the 6 measurement ranges. The A.C. voltage for the bridge is supplied by one winding of the built-in power transformer. Bridge balance is accurately indicated by the open position of the 6E5 visual indicator or "eye" tube. This tube, in conjunction with its 12A7 amplifier, constitutes an extremely sensitive indicator.

For leakage and insulation resistance tests the D.C. voltages (up to 450 volts) are obtained from the built-in supply. The voltages are available in 100-volt steps through buttons 5 to 9 inclusive with variable in-between values obtainable by means of an adjustment knob on the control panel which is calibrated in 10-volt steps. In testing mica or paper condensers, low insulation resistance and leakage are indicated by periodic flashing of the indicator eye. For values up to 1.0 mf. a flash rate not exceeding once per second indicates a satisfactorily low leakage value. For capacities above 1.0 mf. a flash rate up to 2 per second is satisfactory.

Following a logical sequence of tests, the condenser (or capacitor) is first checked for a short, then for leakage and finally for

\* See "Condensers Minus Guesswork," Radio-Craft, Nov., 1939

capacity measurement (and at the same time for open or intermittent conditions and in the case of electrolytics, for power factor). Thus in less time than it takes to tell a complete check on all important characteristics of the condenser is made.

### LEAKAGE

The direct current leakage of any electrolytic condenser is a highly variable factor and no definite boundary line can be established as to what values of leakage constitute a usable and a non-usable condenser. Direct current leakage values normally increase with idle shelf time and also with increase in temperature. In order, therefore, to offset, to some degree, these two factors, it has become a standardized procedure to "age" electrolytics by applying a D.C. voltage, equal to the rated working voltage, to the condenser for 10 minutes prior to making any electrical tests. Also, it is standard practice to make all electrical measurements on electrolytic condensers at a temperature of 21 degrees Centigrade (69.8 deg. F.) or as nearly so as possible.

Since no hard and fast limits can be established, the following tabulation of leakage current values is given for the purpose of determining satisfactory leakage current characteristics.

### DRY ELECTROLYTIC CONDENSERS

Working Voltages	D.C. Leakage in Ma.
25	
50	0.01-ma. per mf. plus 0.5-ma.
100	
150	
200	
250	0.02-ma. per mf. plus 0.5-ma.
300	
350	
400	
450	0.03-ma. per mf. plus 0.5-ma.
500	

### WET ELECTROLYTIC CONDENSERS

Working Voltages	D.C. Leakage in Ma.
25	
50	.02-ma. per mf. plus 0.9-ma.
100	
150	
200	
250	0.03-ma. per mf. plus 1.0 ma.
300	
350	
400	
450	0.05-ma. per mf. plus 1.0 ma.
500	

Testing of electrolytic condensers follows the same general routine as for paper and mica condensers except that leakage is indicated by partial opening of the eye rather than flashing. A red segment opposite the center of the eye opening indicates permissible leakage limits. (See Fig. 2.) If the eye opens beyond this range it is an indication of high leakage and if the eye opens to maximum it indicates a likelihood that the condenser under test is shorted. This can be distinguished from severe leakage by reducing the applied voltage to a relatively low value, in which case a shorted condenser will still show maximum eye opening whereas a leaky unit will show either no opening or only partial opening.

Where excessive leakage is shown the condenser should be left on test for 10 minutes with rated voltage applied. This permits it to age and is sometimes necessary in cases where the unit has been out of service for an extended time. If at the end of this time high leakage is still indicated it is a sign that the condenser (or capacitor) is definitely leaky.

Power factor is checked as the capacity

# RADIO plus TELEVISION

—mastered by pre-tested Training

No matter where you are or what you do, National has a complete training plan for you—to fit your circumstances. National's plan is for those seeking immediate shop-training as well as for those who cannot give up present employment and income. Mail coupon.



### NATIONAL SCHOOLS

NATIONAL SCHOOLS, Dept. 12-RC  
5000 So Figueroa St., Los Angeles, Calif

Please send free literature and full details

NAME \_\_\_\_\_ AGE \_\_\_\_\_

ADDRESS \_\_\_\_\_

CITY \_\_\_\_\_ STATE \_\_\_\_\_

## RADIOS SAVE UP TO 50%

DEAL DIRECT-FACTORY PRICES! Many models to choose from at wholesale prices. A.C. DC midsets \$4.98. Portable and battery sets \$8.98 up. Car sets \$11.75 up. Also consoles, all-wave etc. Samples at 50% off. Send for FREE 1940 bargain catalog giving details of 10 day FREE trial and agent's proposition and discounts. No obligation, write today.

**49c**

Free Catalog

GOLDENTONE RADIO CO., DEPT. RC, DEARBORN, MICH.

## RADIO COURSES

New Classes Start in January  
RADIO OPERATING—BROADCASTING

- RADIO SERVICING — a practical course
- RADIO AMATEUR CODE ● TELEVISION
- ELECTRONICS—1 yr. day course 2 yrs. eve. Day and Evening Classes. Booklet Upon Request.

New York Y.M.C.A. Schools  
4 W. 64th Street New York City

Please Say That You Saw It in RADIO-CRAFT



value is measured and is read directly from a percentage-calibrated dial.

**OTHER USES**

In addition to its application in analyzing and measuring standard condensers, this instrument also serves a number of other utilitarian purposes. It may be used to check capacity between cable wires, transformer windings, wires and shields, etc., and for these purposes is used exactly as in measuring standard condensers.

Or, adjusted for leakage testing, the resistance of all types of insulation can be checked and resistance values computed by means of observing the periodic flashing of the "eye," and applying the simple formula  $R = 50N$ , where  $R$  = insulation resistance in megohms and  $N$  = number of seconds per flash. As shown above a periodic flashing rate of once per second will indicate an insulation resistance of 50 megohms.

When testing capacities below 1.0 mf. flashing will start in less than 1 minute after switches are connected. For higher capacities flashing will take place after several minutes.

The basic flashing rate for all insulation tests will be periodic, at uniform time intervals. If the power line voltage is subject to any abrupt fluctuations the extent of eye opening for the flashes will vary. This does not interfere with the accuracy of measurement as each flash will indicate the same insulation resistance regardless of the degree of opening of the eye.

The Analyzer should be kept in a warm, dry place to avoid moisture condensation on wiring, switches and terminals. It is essential to avoid any internal leakage from this source which might interfere with high insulation resistance measurements.

Direct current continuity tests of all kinds are possible either with inductive or resistive loads. Also the visual indicator section, including the 12A7 amplifier, can be used as a balance indicator for external circuits or as a sensitive A.C. output indicator.

Permissible leakage as well as power factor variations differ somewhat for wet and dry electrolytics, and also depending on the capacity values and the service for which either the condensers or the capacitors are intended. These points are discussed at some length in data available from the manufacturer of this test unit and tolerance limits given for different types of condensers and capacitors, and their services.

In the foregoing no attempt has been made to go into every detail of the functions and operation of this capacity analyzer. But enough has been told to provide some understanding of its ability and advantages, and to create some appreciation of the tremendous possibilities it offers to designers, Servicemen, experimenters, and in fact to everyone who has occasion to use and test capacitors. With such an instrument available, and at a practical price level, there is little excuse for the waste of parts and time involved in condenser tests by substitution and other cut-and-try methods. Further, it enables the Serviceman to reclaim many condensers and capacitors which might otherwise be consigned to the ash can (or to avoid use of those that should have been so consigned) and in all cases to be sure of the units with which he is working.

*This article has been prepared from data supplied by courtesy of Cornell-Dubilier Electric Corp.*

**NEXT MONTH**—How to adapt your present receiver to receive frequency-modulation programs!

# THE Big 3 IN True DYNAMIC TESTING



MODEL 560 VEDOLYZER

The recent announcement of the 560 Vedolyzer, 561 metered output A.F. and R.F. Signal Generator, and 562 Audolyzer has created more interest, and has been received with greater acclaim than any equipment since the beginning of radio service. Thousands of servicemen have written in or called their jobbers for information. More than a hundred orders were placed before prices were announced.

This splendid reception is not strange or unusual, for the service industry realizes that true dynamic testing is much broader and far more comprehensive than so-called channel testing or signalizing. It is not enough to merely locate the stage wherein the trouble lies—it must actually show the serviceman the exact part or component

of the stage which is defective. It must be able to analyze and take into account such factors as distortion, overloading, power handling capability, and a host of other factors vital to the proper operation of the set.

Servicemen have been quick to realize that no other equipment, or combination of equipment, can



MODEL 562 AUDOLYZER

equal the versatility and utility of these new SUPREME instruments.

We want you to actually see and inspect these three new instruments. Have the story first-hand. Get the "feel" of this complete, amazingly different laboratory equipment, which already has the endorsement and approval of well-known radio engineers wherever demonstrated.

You can have DELIVERY NOW! WRITE US TODAY and we will advise you by return mail the name of the jobber for you to see—the jobber in your own locality who has these instruments in stock—and who will be glad to show them and demonstrate them to you without obligation.

You will be interested in this new equipment which you may purchase without fear of obsolescence. Not just for this season or next year, but for years to come—year after year of complete, MODERN service.

**PROVE IT TO YOURSELF—5 DAYS FREE TRIAL IN YOUR OWN SHOP.**



MODEL 561 SIGNAL GENERATOR

## SUPREME

SUPREME INSTRUMENTS CORP. GREENWOOD, MISSISSIPPI, U. S. A.

EXPORT DEPT. Associated Exporters Co. 115 W. 43rd Street, New York. Cable Address: LOPREX, N. Y.

**MAIL COUPON TODAY!**

SUPREME INSTRUMENTS CORP., Dept. C-11, Greenwood, Miss. Advise name of my nearest jobber who can demonstrate SUPREME's New Models 560, 561, and 562.

Name \_\_\_\_\_  
Address \_\_\_\_\_  
City \_\_\_\_\_ State \_\_\_\_\_

**GET A REAL ELECTROPLATING KIT ABSOLUTELY FREE!**

Complete details as to how it is possible to get a Real Electroplating Kit FREE, appear on Page 376 of this issue. TURN TO IT NOW!

**GREATEST SLIDE RULE VALUES!**



10 inch enameled slide rule, made of kiln dried genuine mahogany wood, has auxiliary removable magnifier with pins to fit (cursor) runner. This rule has inch, millimeter, sine, log and tangent scales. Packed in individual carrying case. This rule is equal in performance to a \$10.00 rule. Our special price, F.P. prepaid anywhere... **\$1.00**

8 inch slide rule in case with 36 page illustrated Book of Instructions & Examples. Parcel Post Prepaid **40c**

**GOLD SHIELD PRODUCTS**

Dept. RC-129 350 Greenwich St. New York

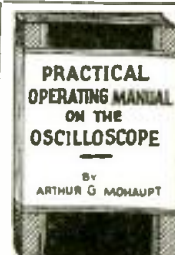

**JUST OUT! A PRACTICAL DISCUSSION OF THE CATHODE RAY OSCILLOSCOPE and FREQUENCY MODULATED SIGNAL GENERATOR**

with applications in modern radio service work. A new book needed by every service man who wants to be up-to-date and know about modern instruments and how to use them in the analysis and alignment of present day receivers. Presented in clear, understandable language, by a man who is a practicing service man and who knows and understands everyday service problems.

**ONLY \$1.00 Postpaid**

Limited Edition. Send order promptly. Don't be disappointed. Send \$1.00, coin or stamp, to Arthur G. Mohaupt, 4523 Ravenwood Ave., Chicago, Ill.

Please Say That You Saw It in RADIO-CRAFT



# FREE TRIAL OFFER

New Remington Deluxe Noiseless Portable!

AS LITTLE AS

**10¢ A DAY**



The New Famous Remington Deluxe Noiseless Portable that speaks in a whisper, is yours for as little as 10c a day. Brand new. Standard keyboard. Automatic ribbon reverse. Variable line spacer. Touch regulator and all the conveniences of the finest portable ever built. PLUS the NOISE-LESS feature. Act now. Send coupon TODAY for details.

**You don't RISK a Penny**

We will send you the Remington Deluxe Noiseless Portable for 10 days' free trial. If not entirely satisfied, send it back. We pay all shipping charges.

**FREE Typing Booklet, Special Carrying Case**

You will receive FREE a complete simplified booklet on Touch Typing prepared by experts. A handsome, sturdy carrying case is included in the price. No obligation. Mail coupon for full details—NOW.

Remington Rand Inc., Dept. 189-12  
465 Washington St., Buffalo, N. Y.  
Tell me, without obligation, how to get a Free Trial of a new Remington Noiseless Portable, including Carrying Case and Free Typing Course on terms as low as 10c a day. Send Catalogue.

Name.....  
Address.....  
City..... State.....

**EXTRA MONEY FOR YOU!** **NOW ONLY 10¢**

**Cash In!**

**NEW 1940 EDITION**  
68 PAGES  
MAIL ORDER PLANS  
TESTED MONEY MAKERS  
BUSINESS SECRETS  
SUCCESS SCHEMES  
A MARVEL BOOK  
40,000 WORDS  
IN TEXT!  
In "CASH IN" you get ALL the real money-makers — dozens of profitable tested mail order plans, confidential business secrets, dozens of practical tested formulas, successful tested schemes—actual experiences of men who have started on a shoestring—with less than \$10 capital. Money-Back Guarantee.  
"CASH IN" contains only tested ideas covering every type of full- or spare-time enterprise—it's a "master-piece" in business ventures.  
10 CENTS per copy. Sent POSTPAID anywhere upon receipt of 10 cents U.S. stamps or coin.

**NATIONAL PLANS INSTITUTE**  
246-R FIFTH AVENUE NEW YORK, N. Y.

**UNIVERSAL G.E. MOTOR** 1/30 H.P. 6 VOLT D.C.

Specifications: 1/30 H.P. Heavy Duty operates on either A.C. or D.C. 110 volts, 3200 R.P.M. with 5' cord and plug. Rheostat can be used to vary speed. Height 3 1/4", Length 3 3/4", Width 3", Shaft 1/8". Can be used to drive Sewing Machines, Models, Buffing Lathes, Polishing Head, Drills, Grindstones, etc. same type motor furnished in 6 volt D.C. Less cord and plug \$1.95.

MOTOR Universal 1/30 H.P. \$2.55  
MOTOR 6 Volt D.C. \$1.95

Shipping weight, either style 3 lbs. Money back guarantee. Send check or M.O. Add 25c for special packing and mailing anywhere in U. S. A.

**WELLWORTH TRADING COMPANY**  
1915 SO. STATE ST., Dept. RC-129, Chicago, Ill.

**High Discounts to SERVICE MEN and DEALERS**

1H5GT	\$1.00	42	\$1.00
1A7GT	1.00	6A8GT	.70
1C5GT	1.00	6Q7GT	.70
30	.70	25L6GT	.90

All Tubes Guaranteed Six Months  
We have a complete line of tubes and tubular replacement condensers—Write for prices and discounts

**NEW YORK RADIO SUPPLY CO.**  
Dept. RC  
152 West 42nd Street, New York City

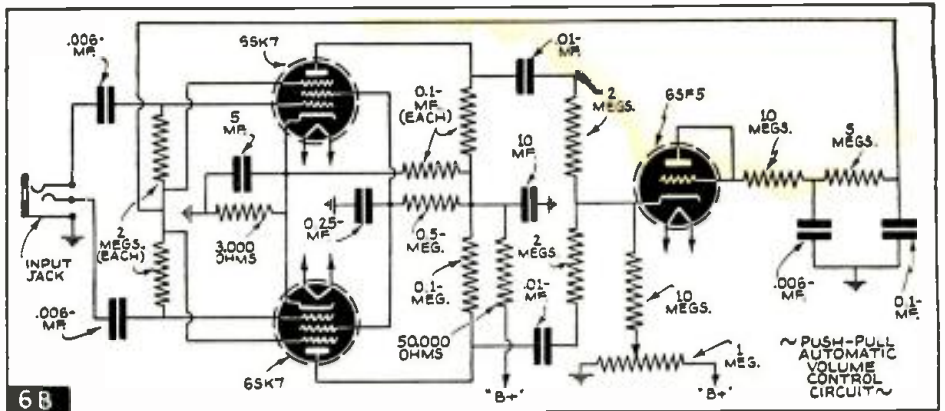

## HOW TO ADD 1 TO 14 MODERN FEATURES TO THE ALL-PUSH-PULL DIRECT-COUPLED 30-WATT P.A. AMPLIFIER

(Continued from page 364)

cycle reading unless the response of the meter and rectifier falls off at this frequency.

Figure 3C. For multiple ranges, additional series resistors should be included, with a suitable switching arrangement, as illustrated in Fig. 3C. The exact voltages of the series resistors will depend upon the db. range desired. Many charts are available which indicate the voltage developed across a 500-ohm line at any output level in db.

### PUSH-PULL AUTOMATIC VOLUME COMPRESSOR

The volume compressor acts directly opposite to the volume expander. A review of the volume expander circuit (described in past issues of Radio-Craft), will facilitate understanding of the compressor circuit.

For expansion, the 6SK7's are negatively biased for low transconductance. The expanding amplifier takes a portion of the input signal, amplifies it, then passes it on to a full-wave rectifier, which develops a positive voltage to oppose the normal high negative bias. The overall result is a reduction in negative bias and an increase in transconductance. This effect produces expansion. For compression, the input 6SK7's have a low negative bias for a high transconductance. The compression amplifier amplifies a portion of the input signal and applies it to the full-wave rectifier, which develops a negative bias. This negative bias increases the original bias to decrease the transconductance (and lower the gain).

Figure 4. Only 2 basic changes are necessary to convert the push-pull expander into the push-pull compressor, namely, (1) a decrease in the 10,000-ohm cathode resistor to 3,000 ohms, and (2) a reverse connection of the rectifier, so as to develop a negative instead of a positive bias. This revised circuit is illustrated in Fig. 4.

### PUSH-PULL AUTOMATIC VOLUME LIMITER

The fine distinction between volume compression and volume limitation is that volume compression may take place without regard to the output of the amplifier, whereas volume limiting must take into consideration the power output developed by the amplifier.

Fundamentally, the volume limiter circuit is similar to the volume compressor, with the exception that the signal which feeds the compressor amplifier, is taken from the 500-ohm output instead of the input which feeds the 6SK7's. This signal is then further amplified, rectified, and applied back as a negative bias to decrease the transconductance of the input 6SK7 tubes. An auxiliary bias voltage is introduced so as to prevent effective rectification from taking place until

some predetermined volume level is attained. Figure 5. This circuit, therefore, acts as a "peak limiter" and simply removes excessive volume surges to keep the output from exceeding some predetermined volume limit. The complete circuit is illustrated in Fig. 5.

### PUSH-PULL AUTOMATIC VOLUME CONTROL

This unique circuit is characteristically different from either the volume compressor or the volume limiter in both its circuit and performance. The automatic volume control automatically maintains a given volume output. That is, it actually increases the gain of the amplifier when the input level drops; and conversely, decreases the gain of the amplifier when the input level increases.

Naturally, the controlling voltage must be taken from the output of the amplifier. This is fed into a biased rectifier and then applied through a time-delay circuit to the control- and suppressor-grids of the 6SK7 to either increase, or decrease its transconductance.

Figure 6A. The fundamental circuit is illustrated in Fig. 6A. It will be noted that the output tube feeds through a small coupling condenser and large resistor directly into the bias 6SF5 cathode. The positive portions of the cycle pass directly to ground through the 10-meg. and biasing resistors. The negative portions, however, pass to the grid and plate of the 6SF5, which build up a charge across the 0.006-mf. condenser through the 10-meg. plate-grid series resistor. The negative charge across the 0.006-mf. condenser is then applied through a time-delay circuit (which may be made variable) composed of a 5-meg. and a 0.1-mf. condenser. By adjusting resistor R1, the range of control may be varied. At maximum setting, constant output is maintained with a 30 db. variation of the input signal. This unusual controlling range offers a wide latitude of movement to orators employing "fixed position" microphones.

Figure 6B. The push-pull version of the automatic volume control circuit is illustrated in Fig. 6B.

This article has been prepared from data supplied by courtesy of Amplifier Company of America.

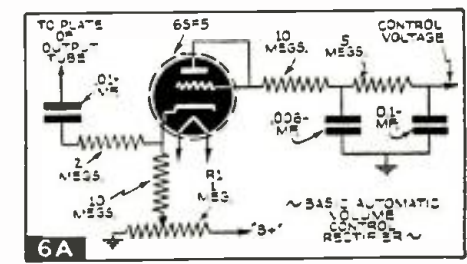

Please Say That You Saw It in RADIO-CRAFT



### NEW RATINGS FOR XMITTER TUBES

Transmitter tubes by having both ICAS and CCS ratings, now may be operated under characteristics that best suit a particular type of operation—amateur radio, broadcasting, etc.

An entirely new system of ratings for air-cooled transmitting tubes has been announced by RCA Manufacturing Company, Inc., of Harrison, N. J. Instead of one set of maximum ratings for each tube type, two sets of maximum ratings are given. These ratings are designated:

- (1) "Continuous Commercial Service" (CCS); and,
- (2) "Intermittent Commercial & Amateur Service" (ICAS).

The CCS ratings are essentially the same as the former maximum ratings. The ICAS ratings, however, are considerably higher, permit the use of much greater power input, and provide a relatively large increase in useful power output. For example, the A.F. power output of two 809's in class B is 100 watts at the old maximum plate-voltage rating of 750 volts. At the new ICAS rating of 1,000 volts, the power output is 145 watts—an increase of 45 per cent. In plate-modulated telephony service, the R.F. output of the 809 is 38 watts with the CCS ratings and 55 watts with the new ICAS ratings—also an increase of about 45 per cent.

The new system provides transmitting-tube ratings which recognize the diversified design requirements of modern transmitter applications. For example, there are numerous applications where the design factors of minimum size, light weight, low initial cost, and maximum power output are far more important than extremely long tube life. In such cases, the set designer may very properly decide that a small tube operated with ICAS ratings better meets his requirements than a larger tube operated with CCS ratings.

**Ham Radio**—It is self-evident, of course, that the harder a tube is worked the shorter will be its useful life. Although no rule can be set up which will accurately predict the life performance of an individual tube under specified operating conditions, it is practical to make an estimate of tube life on the basis of average results from a large number of tubes. In average amateur-radio service, a tube operated at the higher ratings can normally be expected to give about 50 per cent of the life obtainable with CCS ratings.

It has been estimated that an active amateur does not have his carrier on the air more than 300 hours per year. Therefore, a tube lasting 1,000 to 1,500 hours when used with CCS ratings would give him at least 3½ to 5 years of service. The amateur, because he is usually most interested in low initial cost and maximum power output, may consequently decide that the ICAS ratings are better suited for his purpose.

**Broadcasting**—The engineer designing a broadcast transmitter has quite a different problem. A broadcast station may operate tubes on an average of 18 hours a day. Tube failures are expensive both in themselves and in advertising revenue lost because of interrupted programs. Consequently, since reliability is his main concern, he should operate tubes at the CCS ratings, or perhaps even lower. Only in this way can he obtain the long tube life required for continuous commercial services.

**Airplane Radio**—In airplane transmitters, tubes may be operated only a few minutes a day. In addition, mechanical failure of tubes may occur prematurely due to the severe vibration and shock to which they are frequently subjected. For these reasons, operation of tubes at ICAS ratings, especially where maximum power output for a mini-

# FOR THE LOVER OF FINE MUSIC OR THE "DX" ENTHUSIAST

who wants Magnificent Tonal Realism

who wants Amazing Long Distance Performance

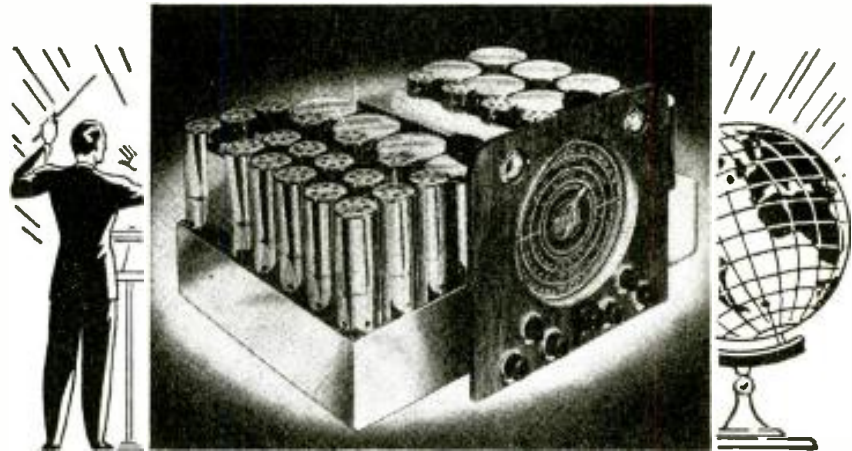

## "World's Finest Radio"

Scott Radio has pioneered superb, natural tone and CLEARER long distance reception, for 16 years. These magnificent, laboratory Custom Built instruments offer a degree of performance (broadcast, short wave, and recorded music) which we believe is not even remotely approached by any other radio in the world! They are treasured by famous musicians (including Toscanini, Barbirolli, Iturbi, Menuhin, Bonelli), diplomats, scientists, "DX" enthusiasts, and critical listeners in 151 countries.

### GUARANTEED 5 YEARS 30 DAYS' HOME TRIAL

Built with fine watch precision, a Scott is guaranteed 5 years . . . 20 times longer than the 90 days adopted as standard by the radio industry. Almost 90% are bought "SIGHT UNSEEN" through recommendations. Exquisite new custom built cabinets by Scott master designers are available for radio only or radio and record player. Scott Automatic or Single Record Players can be included for those who want finest possible reproduction of high fidelity recorded music.

You can enjoy a Scott for 30 days before deciding whether you want to keep it. Budget terms in U.S. if desired. You deal direct with Scott Laboratories, never thru stores. The SCOTT is generally considered the "World's Finest Radio" . . . guaranteed to outperform any other radio in the world . . . yet costs no more than many mass production type receivers. Send today for all facts and laboratory measurement proof!

GET SPECIAL MONEY SAVING OFFER • MAIL COUPON TODAY!

**A FEW OF MANY AMAZING FEATURES**

Many exclusive, far advanced features developed in our own engineering laboratories are included in Scott Radio design.

- 6 noise reducing systems
- 6 wave bands from 3.75 to 2000 meters including ultra high frequencies
- overall fidelity 30 to 16,000 cycles
- 40-60 watts undistorted Class A power output
- Continuously Variable Selectivity from 2 to 16 Kc. Sensitivity from .05 m. to 20 m.
- Record scratch suppressor.

Calibrated and tested with the most infinitely accurate measuring devices known to science, each Scott is as perfect an instrument as skilled human hands can produce.



**E. H. SCOTT RADIO LABORATORIES, INC.**  
 4404 RAVENSWOOD AVE., DEPT. 24W9, CHICAGO, ILLINOIS

Send special offer, order blank, and all facts on new Scott Philharmonic, Phantom De Luxe, and Masterpiece models. Also send Scott Record Review. No obligation.

Name .....

Street .....

City ..... State .....

STUDIOS: NEW YORK BUFFALO DETROIT CHICAGO LOS ANGELES

**ALMOST READY NOW —**  
**The Latest Radio-Television Reference Annual**

Keep a weather eye peeled for the opening announcement, in the next issue, of the new yearly book, 1940 RADIO-TELEVISION REFERENCE ANNUAL. Always a handy and important reference work, this large 64-page book is a compendium of the most important articles and radio information of the year. Its pages cover practically every branch of radio, viz., sound, public address, servicing, television, construction articles for beginners and experimenters, construction articles for advanced radio men and technicians, time- and money-saving kinks, wrinkles and useful circuit information. "Ham" transmitters and receivers, and a host of other essential data.

Be on the lookout for the announcement in the next issue. Only a limited edition will be printed and—first come, first served.

**RADIO ENGINEERING**

RCA Institutes offer an intensive course of high standard embracing all phases of Radio and Television. Practical training with modern equipment at New York and Chicago schools. Also specialized courses and Home Study Courses under "No obligation" plan. Catalog Dept. RC-39.

**RCA INSTITUTES, Inc.**  
 A Radio Corporation of America Service  
 75 Varick St., New York 1154 Merchandise Mart, Chicago

**SEARS-ROEBUCK'S 1940 CATALOG**

**FREE**

Send today for this new catalog of nationally advertised radio equipment, test instruments, and sound systems. Ask for Catalog RCRI32D.

SEARS, ROEBUCK AND CO., CHICAGO

**DON'T BUY UNTIL YOU SEE IT!**

Please Say That You Saw It in RADIO-CRAFT

*Mr. Serviceman:  
"Be First  
with R.S.A!"*



*Let's Grow Together in 1939!*

**MAIL THIS COUPON NOW!**

RADIO SERVICEMEN OF AMERICA, INC.  
304 S. Dearborn St., Chicago, Ill.

Name .....

Address .....

City ..... State .....

I am interested in RSA Membership. Tell me about it.....

I am enclosing \$4.00 for National dues and initiation.....

(Does not include Local Chapter dues where Local Chapters are organized.)

RC-1230

**HISTORY MAKING FIRSTS**

- FIRST and only national service organization to have sponsorship of RMA, Sales Managers Club, and all radio trade journals.
- FIRST national service organization to have bonded employees and officers—with a democratic setup run entirely by servicemen elected by and from the membership.
- FIRST service organization to have a cooperative agreement with broadcasters to sell RSA to the American public and to put into effect plans for making the service industry a profitable, year-round business.
- FIRST and only service organization to provide a Guaranteed Service Plan for protection of its members and their customers.

**RADIO SERVICEMEN OF AMERICA, Inc.**

**JOE MARTY, JR., EXECUTIVE SECRETARY**  
304 S. DEARBORN STREET, CHICAGO, U.S.A.

*(Continued from preceding page)*

mum size and weight is essential, should be considered. On the other hand, there are installations where it is imperative that the tubes be ready for operation at all times, because failures at the wrong moment may mean damage to an expensive airplane or even loss of human life. The choice of tube operating conditions for any service must, therefore, be based on a careful consideration of all factors.

**ICAS—CCS,—A COMPARISON**

In view of the fact that the ICAS ratings are considerably higher than the former maximum ratings, an explanation of the basis on which these new ratings are established is desirable. The old method of rating transmitting tubes has been based on the assumption that tubes would always be used under the most severe operating conditions possible for each class of service. Although it was recognized that this method was not representative of actual operating conditions, it did provide a very large factor of safety. In recent years, rapid progress in tube design, tube manufacture, transmitter design, and operating technique has made it practical to refine the method of rating transmitting tubes so that it more closely represents actual operating requirements.

**Class C**—For example, in class C telegraph service, the old ratings were set up on the basis of continuous, key-down operation. In practice, however, all class C stages which are keyed are not under load when the key is up, as for example during spacing intervals. The average load on the tube is, of course, much less than it is under steady, key-down conditions.

In class C plate-modulated telephony service, the old ratings were based on steady, 100 per cent, sine-wave modulation. Under

this condition, the total plate input (D.C. and A.C.) is 1.5 times the unmodulated D.C. plate input. In practice, a broadcast transmitter (for example) modulates its carrier on the average only 25 to 30 per cent. Under these conditions, the average plate power input is only 5 per cent higher than the unmodulated D.C. plate input.

**Class B**—Similarly, the old class B A.F. amplifier ratings were based on steady, full-signal operating conditions with a sine-wave signal. Actually, the average signal is much smaller than the maximum value and the average plate D.C. and power input vary continuously between no-signal and full-signal values. In addition, it is well known that speech signals place a much lighter load on the class B amplifier than signals having sinusoidal waveform.

In class B R.F. amplifier service, the old ratings were based on carrier conditions where the carrier output represents 1/3 of the D.C. plate input and the other 2/3's portion is dissipated by the plate. At 100 per cent modulation, though, the efficiency of the amplifier increases to approximately 50 per cent, so that the plate dissipation is reduced about 25 per cent. However, because the average decrease in plate dissipation is rather small, the ICAS ratings for this class of service have to be more conservative than for the other services.

It is apparent from the foregoing considerations that increased transmitting-tube ratings are practical for many applications. The new ICAS ratings, together with the CCS ratings, make it possible for the radio amateur and the radio engineer to choose the operating conditions best suited for the job at hand. Undoubtedly, the introduction by RCA of this new system of double ratings for transmitting tubes represents a most important contribution to the art.

Complete operating data, including both CCS and ICAS ratings, have been prepared for RCA types 802, 804, 806, 807, 809, 810, and 814, as well as for the new 811, 812, and 828, and can be obtained on request.

(Partial operating data for the latter 3 tubes will appear in the forthcoming, January issue of *Radio-Craft*.—Editor)

**NOVEL P.A. INSTALLATION WINS 1st PRIZE IN CONTEST**

*(Continued from page 361)*

better. This job has run nearly 6 months now with no breakdowns.

Note: The problem "How installation problems were solved" is included in the "Technical Problems" as the two are tied-up in each other.

**COST OF EQUIPMENT, ETC.**

The amplifier, audio distribution and speaker transformers, automatic record player, 3,000 feet of parallel A.C. cord, speakers, magnet wire, condensers, mixer parts, and batteries were bought from a radio mailorder house.

Total cost of above items .....	\$280.00
Telechron motor and parts for clock .....	15.00
Radio receiver .....	15.00
Isolation transformer (special) ....	8.00
Industrial howlers .....	30.00

Total cost of material .....	\$348.00
Contract price .....	\$750.00
Material .....	348.00

**\$402.00**

Labor (included in this \$402.00 but still a nice profit).

Labor of myself and one helper for 5 1/2 days.

Please Say That You Saw It in RADIO-CRAFT



## NEWEST TUBE CHECKER

(Continued from page 341)

2. Insert the tube in the proper socket of the tester and attach the grid connector if the tube is equipped with a top contact.

3. Test initially for short-circuited elements by depressing the "SHORTS" button, which will lock-in, and then pressing in consecutive order the buttons numbered 1 to 8. If the neon lamp glows steadily, a short-circuit is indicated and the tube should be discarded.

*NOTE—(On some tubes, the neon lamp should glow when certain buttons are pressed as indicated by the word SHORTS printed on the chart opposite such buttons.)*

4. Assuming that the tube is not short-circuited, proceed to the emission test by depressing the TEST button which will lock-in and release all other buttons. Now, press the numbered buttons opposite the corresponding numbers found on the chart. Check the line voltage and readjust the LINE VOLTS control if necessary. Finally, depress the OUTPUT button and observe the condition of the tube on the GOOD-POOR scale of the meter. In the case of diodes, any tube which does not cause the pointer to rise to the DIODES OK mark should be rejected.

*NOTE—More than one test may be required to determine completely the condition of a tube. For instance, the type 1A6 will require 2 tests, one each for the oscillator and converter sections. Similarly, 3 tests will be employed for the type 1B5, one for the triode section and one for each diode section. Such multiple tests are given in order on the chart where involved.*

5. A test for noise may be made if desired by plugging a pair of phones into the jack located at the lower right-hand corner of the panel and listening for "crackle" while tapping the tube. The TEST button should be left depressed during this test.

*CAUTION—Incorrect results (low meter readings) will be obtained if the phones are left plugged into the noise jack during emission tests. The error will involve only the output measurement — not the LINE CHECK.*

6. If any doubt still exists as to the tube condition, it will be advisable to repeat the short-circuit test. Excessive leakage may become evident after the tube has been heated over a longer period although the initial test usually will reveal such a defect.

**Tuning Indicator (Magic Eye) Tubes.** Certain tubes of this type contain an amplifier section which should be tested for short-circuits and emission in the same manner as for receiving tubes.

To check the indicator section, set the CLASS control on position H, thus reducing the applied potential to 110 volts. This reduced potential is desirable since such tubes often are used under analogous conditions in A.C.-D.C. receivers. Depress the TEST button and the numbered buttons indicated on the chart which will cause the "eye" to appear lighted. The "eye" should operate upon following the instructions printed on the chart directly above the OUTPUT button, the latter not being used for this test.

**Cathode-Ray Oscilloscope Tubes.** The types 902 and 913 cathode-ray tubes can be checked with this tester. Its use in testing other tubes of this variety is not recommended.

In testing the type 902 or the type 913 tube, allow at least 2 minutes preheat before checking the emission. The testing procedure is the same as for receiving tubes, rejecting those on which the emission is not sufficient  
(Continued on page 373)



Save money  
2 ways with  
RCP TEST  
EQUIPMENT

## Pay Less . . . .

# Increase Profit

Experimenters and servicemen agree: best value in test equipment today is RCP! You save when you buy RCP equipment because every instrument in the line is priced lower—costs less to own. You save again every time you use RCP equipment because these precision testers work more quickly and accurately, perform more service jobs, last longer—increasing profit for you! See your jobber today—check RCP features and prices against the field.

**RCP MULTITESTER MODEL 409A**

ACCURATE WITHIN 2%. Sensitivity 2000 ohms per volt. Exclusive system of AC measurements insures full accuracy at all frequencies, avoiding errors due to temperature and wave form. Ultra sensitive ohmmeter has low range scale reading only 2 ohms at center. High range ohmmeter gives wide spread readings at 10 megohms with completely self contained power supply. Can be used on both DC and AC lines or at any frequency AC. Net **\$17.95**



**RCP ANALYZER UNIT MODEL 505**

MAKES A COMPREHENSIVE free point, free reference system and set tester when used with any suitable multi-tester. A multiple selector circuit system provides for metering at all socket terminals for current, voltage resistance and capacity. Permits tube testing from radio receiver chassis. Future requirements provided for by 10 wire cable including spare and also a spare terminal at the panel. Can easily be mounted in cover of any instrument. Complete with latest design toggle latch, bakelite plug and 7 latch lock adapters. Net **\$9.95**



**RCP MULTITESTER AC-DC Model 445**

IN APPEARANCE AND QUALITY this general test instrument is in a class with testers selling for twice the price. Actually, it is the equivalent of 25 different instruments. D'Arsonval meter accurate within 2%. Five range DC voltmeter 0/5/50/250/500/2500. Four range DC milliammeter 0/1/10/100/1000. DC Ammeter 0/10. Four range AC voltmeter 0/10/100/500/1000. Three range ohmmeter 0/500/100,000/1 meg. Four decibel ranges -5 to -15/12 to 35/26 to 49/32 to 55. Meter sensitivity 1 Milli-ampere or 1000 ohms per volt. All in a single attractive panel case **\$9.95** complete with batteries. Net **\$9.95**



**RCP COMBINATION TUBE AND SET TESTER MODEL 801**

NOWHERE COULD YOU BUY these two essential instruments individually and get the same high quality at the same low price. Tests all new and old tubes and ballast tubes; hot interelement short and leakage tests on each individual element. Smooth line voltage regulation 103 to 135 volts with direct meter indication. As multitester, Model 801 provides four range D.C. voltmeter 0/10/50/500/1000; A.C. voltmeter 0/10/50/500/1000; D.C. milliammeter 0/1/10/100/1000; D.C. amps 0/10. Four range ohmmeter up to 10 Megohms. Also D.B. meter and output meter. Fused D'Arsonval Meter Antico Magnet. Compact, light, with slip hinged cover case. Complete with tube, battery and test leads. Net **\$27.95**



**RCP DYNOPTIMUM TEST TUBE CHECKER MODEL 308**

Tests (under R.M.A. specified plate voltages and loads) 35-45-50-70 up to 117 volt tubes all metal, M.G., glass, OZA, cold cathode rectifiers, octal, loctal and single end tubes. Tests all ballast tubes (separate chart included.) Hot interelement short and leakage test between ALL INDIVIDUAL ELEMENTS. Provision for audible test of noisy tubes. Net **\$16.95**



See your jobber today, or write direct for detailed information on the complete RCP line.

# RADIO CITY Products Co.

88 PARK PLACE NEW YORK CITY

### RADIOODDITIES

**R**ADIO signals recently traveled a distance of 35 miles to carry a message 25 ft., in New York City!

A fire department employee driving one of the F.D. automobiles equipped with 2-way radio couldn't arouse the building superintendent in order to get into the building which houses WNYC's transmitter. He called from his car to the central station in the middle of Central Park and his message was relayed over WNYC's master control room on the direct radio wire to the Municipal Building. There the master control called the WNYC transmitter on another direct radio line with the result that the building superintendent walked a few feet and opened the gate.

Treat Yourself or Your Friends to a PRACTICAL Christmas Gift!

"JIFFY"

Magazine Binders

Sturdily built and covered with black fabricoid. Has two stamped metal ends with 12 spring wire separators. Magazines can be inserted and removed in a jiffy. No fuss—no lost time—no labor.

No. 1. 12"x9 1/2", with 2-inch back for Radio-Craft, R.&T., Radio News, etc.	\$1.50
No. 2. 10 1/2"x7 1/2", with 3-inch back for QST, Radio, Popular Mechanics, etc.	\$1.25
No. 3. 8 1/2"x6 1/2", with 3-inch back for Reader's Digest, etc.	\$1.00

P.P. Prepaid in U.S. and Canada. Send for catalog containing full descriptions of many other interesting items.

GOLD SHIELD PRODUCTS

Dept. RC-129 350 Greenwich St. New York

Please Say That You Saw It in RADIO-CRAFT



# A new way to EXTRA PROFITS with PYRO PANTAGRAPH

Size of box: 12 1/2" x 8 1/2"

With this PYRO PANTAGRAPH turn leisure time into profitable hours. Make money a novel, easy way—'Burn Your Way to Extra Dollars with Pyro Pantagraph.'



**\$2.75**

Shipping weight, 3 lbs.

This electrical outfit is especially designed for burning designs permanently on Leather, Wood, Cork, Gourds, Bakelite, etc. Simply plug the Pyroelectric pencil in any 110-volt AC or DC outlet and it is ready to be used. Plug and cord furnished as part of equipment. By the use of a special Pantagraph included in the outfit, any design may be reproduced either in original, reduced or enlarged form. Outfit consists of: one Pyro-electric Pencil; one Pantagraph; three hardwood plates; one bottle of Vaseline; one Brush; one tracing tip and four-page instruction sheet.

Outfit will be forwarded by Express Collect if not sufficient postage included with your order.

**WELLWORTH TRADING COMPANY**

1915 S. State Street, Dept. RC-129, Chicago, Ill.

## MIDWEST FACTORY-TO-YOU 20th ANNIVERSARY SPECIAL!



### WITH TELEVISION ADAPTATION

Here's today's biggest radio value—the 1940 TELEVISION-ADAPTED Midwest at sensationally low factory-to-you price. Now enjoy exciting foreign reception. Absolute satisfaction guaranteed on money-back basis. Send in postcard for FREE 1940 Catalog. (User-agents make easy extra money!)

See Midwest's Answer to TRADE-INS!

**PUT THIS 1940 14 TUBE CHASSIS IN YOUR PRESENT CABINET**

**\$19.95**

COMPLETE CHASSIS WITH TUBES AND SPEAKER!



**14 TUBE CONSOLE \$29.95 COMPLETE**

**SAVE UP TO 50% 30 DAYS TRIAL EASY PAY PLAN**

**MIDWEST RADIO CORPORATION DEPT. 12-B CINCINNATI, OHIO**

### REMOTE CONTROL FOR A. C. RADIOS



A wireless remote control that tunes ANY electric set! Without wires to your radio! From distances up to 20 ft. you can tune your 6 favorite stations by just touching a button! Change the volume, too! Just plug the Remote Control in any electric outlet. Handsome cabinet. Size: 4 1/2 x 6 1/4 x 3 3/8 inches. Complete with 3 tubes and instructions. For 110-120-volt, 50-60 or 25-cycle A.C. or D.C. SHIP wt., 6 lbs.

List Price \$20—Your Price **\$4.88**

**ARROW SALES CORP., 619 W. Randolph, Chicago, Ill. Send for 24 page catalog.**

**LE'S Correspondence Courses in RADIO and ELECTRICAL ENGINEERING**

**ELECTRICAL ENGINEERING** Get good grasp of wide electrical field. Prepare yourself, at Low Cost, for secure future. Modern, simplified, you can understand quickly.

**RADIO ENGINEERING** Extra fine course in radio, publication, photo-electric work. Trains you to be super-service man, real vacuum tube technician. Exper. kits furnished. Diploma on completion. Tuition, \$25. either course. Deferred payment plan.

**FREE** Get copies of school catalogs, student magazines, complete details. **SEND NOW!**

**LINCOLN ENGINEERING SCHOOL, Box 931-612, LINCOLN, NEBR.**

## NEWEST HI-FI 9-TUBE SUPERHET. INTRODUCES "HARMONIC CONVERSION"

(Continued from page 332)

### LIST OF PARTS

#### CONDENSERS

- Seven Sprague, 0.1-mf., C1, C2, C3, C6, C12, C13, C18;
- Five Sprague, 0.05-mf., C4, C5, C11, C14, C23;
- Two Sprague, 100 mmf., C7, C15;
- Three Sprague, 0.05-mf., C8, C10, C19;
- One Sprague, 1.0 mf., C9;
- One Sprague, 50 mmf., C16;
- One Sprague, 0.02-mf., C17;
- Three Sprague, 8 mf., 450 V., C20, C21, C22;
- One Sprague, 200 mmf., C24.

#### RESISTORS

- Two I.R.C., 300 ohms, 1 W., R1, R2;
- Two I.R.C., 500 ohms, 1 W., R3, R10;
- Four I.R.C., 0.1-meg., 1/2-W., R4, R5, R9, R12;
- Three I.R.C., 2 megs., 1/2-W., R6, R13, R18;
- Two I.R.C., 1.0 meg., 1/2-W., R7, R8;
- One I.R.C., 400 ohms, 1 W., R11;
- Two I.R.C., 50,000 ohms, 1/2-W., R14, R22;
- One Centralab volume control and switch, 0.5-meg., R15;
- Two I.R.C., 0.5-meg., 1 W., R16, R17;
- One I.R.C., 0.5-meg., 1/2-W., R19;
- One I.R.C., 30,000 ohms, 2 W., R20;
- One Ohmite voltage divider, 10,000 ohms, R21.

#### TUBES & SOCKETS

##### Glass

- Four type 58;
- One type 2A5;
- One type 2A6;
- One type 2A7;
- One type 2B7;
- One type 5Z3;

Metal Tubes may be used instead as follows:

- Four type 6K7;
- One type 6A8;
- One type 6B8;
- One type 6Q7;
- One type 6V6;
- One type 5U4;

Sockets used in the original receiver:

- One 5-prong wafer;
- Two 7-prong wafer;
- Five 6-prong wafer;
- One 4-prong wafer;
- One Mallory bias cell, and holder.

#### MISCELLANEOUS

- One chassis, 10 x 12 x 3 ins. (a larger chassis is better suited);
- One Crowe dial for self-numbering;
- One small 3-gang tuning condenser, max. cap. 365 mmf.;
- One General Transformer Corp. antenna transformer;
- One General Transformer Corp. interstage transformer;
- One oscillator transformer (I wound this myself to track 150 kc. I.F.);
- One band-expansion transformer (made special for 150 kc.);
- One Hammarlund output transformer, 175 kc. made to tune to 150 kc.;
- Two Hammarlund "variable coupling" I.F. transformers, 465 kc., with control for 2 I.F.'s. (These transformers are made to tune to 450 kc.);
- One Hammarlund output transformer, 465 kc. made to tune to 450 kc.;
- One 6-in. (or, for larger receiver, 12-in.) speaker; the 6-in. speaker used in the original receiver is a Wright-DeCoster with a 300-ohm field, tapped at 200 ohms for semi-fixed bias for power tube;
- One Thordarson filter choke, type No. T-13C30, 8 henries, 150 ma.;

One Thordarson power transformer, either type T-56R04 or T-70R62), one is 2.5 V. filament, other 6.3 V. filament (Lehigh, originally used, is not available);

Padding condenser for 150 kc. is 0.001-mf. (Cp) shunted with a variable, 150 mmf. (Cpv).

Note 1: The photograph shows a 150-kc. variable coupling transformer with adjustable control at the top. This is being changed to a band-expansion type with electrical control in the front. This control is a 3-position unit which has already been tried with excellent results.

Note 2: The loudspeaker used by the author is a 6-in. Wright-DeCoster reproducer with a 300-ohm field. It can be used in midget receivers because the low-frequency response is limited. A preferable unit is a Jensen A12 P.M. speaker with a resistor inserted in the circuit to give the receiver the proper semi-fixed bias for the power tube. The output of the latter is approximately 3 W. undistorted, at 400 cycles (as measured from antenna post to speaker).

With the volume level constant, and the fidelity control in the MAXIMUM BROAD position, the output at 9,000 cycles was approximately 2 W., undistorted. This drop in response was traced to the output transformer and speaker. There is also a slight drop in response in the audio amplifier. (The wide-range loudspeaker, for "frequency modulated" receivers, described elsewhere in this issue probably would show up to good advantage in this "3rd-Harmonic Superhet."—Editor)

All the audio frequency measurements were made with a new-type instrument invented by the author to instantly give a dynamic visual response through the tuner from 120 cycles per second to 15,000 c.p.s. on the screen of the oscilloscope. The BAND EXPANSION positions were instantly viewed on the screen of the oscilloscope from Maximum Selectivity to Maximum Fidelity.

Any questions? They may be addressed to the attention of the writer, c/o Radio-Craft. Don't forget to enclose a stamped, return-addressed envelope, please.

## THE RADIO MONTH IN REVIEW

(Continued from page 351)

### BROADCASTING

Canadian radio broadcast stations and the government have issued statements to the effect that "Radio employees will be just as important manning the microphone as the gun", according to Variety's Radio Section, last month.

According to newspaper reports last month, a sound-effects man who also knew the telegraphic code was surprised, no end, to find a pile of letters in the mail on the morning following a broadcast in which he had been called upon to "pound brass." It seems that he had absentmindedly dot-dashed the comment, "Boy, does this show stink . . . What an awful clambake!"

Please Say That You Saw It in RADIO-CRAFT



### NEWEST TUBE CHECKER

(Continued from page 371)

to cause the pointer to rise to the DIODES OK mark.

**Gaseous Regulator Tubes.** These tubes should be tested initially for short-circuit and then for breakdown voltage.

For the short-circuit test, the procedure is the same as for receiving tubes. Due to the gaseous nature of these tubes, the neon lamp may glow faintly upon pressing button 1 or 3 in testing the type 874, or upon pressing button 1 or 5 in testing the others. The tube, however, should not be rejected unless the glow is brilliant.

To test for breakdown voltage, depress the TEST button and then the numbered button indicated upon the chart. If the tube is good, the meter deflection will rise appreciably, whereas little or no rise will occur if the tube is poor. The OUTPUT button is not employed in this test.

**Ballast Tubes.** Tubes of this type should be tested initially for open-circuit and then for incipient noise due to poor welds. Both tests are performed with the CLASS control on position I and the SHORTS button depressed.

In testing for open-circuits, press the numbered buttons indicated upon the chart which in each case should cause the neon lamp to glow. Failure to observe this glow is evidence of a defective tube.

The test for incipient noise is effected by listening for "crackle" through a pair of phones plugged into the jack located in the front right-hand corner of the panel. Defects of this nature usually are the result of poor welds and the noise will be exaggerated by tapping lightly upon the tube envelope.

Common type numbers of these tubes are listed in one column of the previously-mentioned chart, while the corresponding Clarostat (tentative R.M.A.) type numbers are given in another column.

**Miniature Base Lamps.** Located between the LINE VOLTS and FIL. VOLTS Controls, is the socket for testing miniature-base lamps. The voltage applied between the contacts is that shown by the setting of the FIL. VOLTS Switch.

**WARNING—A maximum of 120 volts can be obtained from the contacts of this socket.**

**Special Rectifiers.** Some special rectifiers used for voltage doubling purposes have their plates connected, internally, to their heaters. Normally, on emission tests, the cathode is connected to the heater and the plate is connected through the D.C. (Good-Bad) Meter to the high side of the power transformer. However, with these special rectifiers, since the tube effectively has its connections reversed, it is necessary to reverse the meter connections. This is accomplished by depressing both the SHORTS and TEST buttons simultaneously for the correct TEST position. It should be noted that further depression of either the TEST or SHORTS button will release all other buttons.

Adjustment for different plate loads and voltages as required is provided by the CLASS control. This control also shifts the filament connections for the octal-base tubes and is equipped with an extra set of switch contacts to avoid obsolescence of the tester in the event of forthcoming new tube types. The TYPE control is simply a meter shunt or calibrating potentiometer, while the remaining knobs and buttons are self-explanatory in function.

**NEXT MONTH—A combined F.M.-A.M. adapter for your present receiver. Don't miss this important development!**

## JUST OUT SYLVANIA'S BIGGER AND BETTER..

Send for your copy of this big "tube fact" book today

The 1940 Sylvania Technical Manual is bigger and better than ever with a new easy-to-use arrangement. It has 264 pages packed with vital tube information for servicemen, radio technicians, engineers and amateurs.

It gives you complete data and tube diagrams for 344 types of tubes all now listed in numerical-alphabetical order for quicker reference. Operating conditions, characteristics and circuit applications for standard glass tubes, "G" types, "GT" types, Loktal, Metal, Majestic and special types. Full information, too, on Sylvania's complete line of panel lamps.

The new Manual also includes data on special tubes for particular applications in television amplifiers, cathode-ray tubes, etc., with new circuit information and diagrams covering the latest type tubes.

Send the coupon for your copy! This new edition is a bargain at only 35c.



# SYLVANIA

Set-Tested Radio Tubes

**HYGRADE SYLVANIA CORP.**  
Emporium, Pa.

Here is 35c. Please send me a copy of the bigger and better Sylvania Technical Manual.

Name .....

Address .....

City .....

State .....

Serviceman  Experimenter   
RC-129 Dealer  Amateur

## COMPLETE RADIO COURSE \$1.95

### Amazing Offer of R. T. I. Training



#### GREATLY REDUCED

A limited number of the latest R.T.I. \$39.00 radio courses have been reprinted and are offered to you for only \$1.95. These courses are complete in all details and exactly the same as the higher priced originals.

New modern developments help to make Radio the present-day opportunity field. Men like you studied Radio Servicing for a short time and today are making real money in radio. R.T.I. unique radio training will bring rich rewards to you. You can get ready quickly, inexpensively, easily, and in your spare time for a good job in radio.

#### ACCEPTED BY INDUSTRY

Forty-three large radio manufacturers helped to prepare the R.T.I. course. Just think what this backing by the radio industry means to you. R.T.I. practical training will give you facts and real data you will need on the job. Hundreds of diagrams and illustrations to help you. You will pass quickly from lesson to lesson and in surprisingly short time will be ready to do real radio servicing and earn bigger money.

#### COMPLETE IN ALL DETAILS



Arthur Gold says, "From the very start I learned about practical equipment and methods. I was told how to open my own shop. You can earn spare-time money on radio repair jobs before you reach the fourteenth lesson."

R.T.I. course will give you all the radio training you need. No special previous education or experience is needed. The lessons are clear, interesting, easy to master and use. Fellows who knew nothing about radio before taking a home-study radio course are now the leading servicemen in their communities. The special \$1.95 price of the complete course can be earned in a single hour's work of radio servicing. This is your opportunity.

#### Your Guarantee

You must be pleased, or your money will be cheerfully refunded. We guarantee these courses to be exact reprints from original Radio Technical Institute course.

#### 3 COURSES IN ONE

R.T.I. course is really three complete essential courses combined. You get training in (1) Practical and Applied Radio; (2) Fundamentals of Radio Principles; and (3) Advanced Specialized Training. This is the training that will place you above the average radio servicemen—and you get this training for only \$1.95.

There are over 40,000,000 radio sets in use. The R.T.I. easy practical course will pave the way to your success in radio work. A final examination may be taken and diploma obtained if wanted.

#### TELLS HOW TO USE INSTRUMENTS

The training is complete. Everything from simple facts to complex alignment problems. Many servicemen have found that R.T.I. training is excellent for brush up and study of modern servicing methods. This is the best buy in a radio education. Take advantage of the reduced bargain price today.

#### LATEST DATA



Yes, in the R.T.I. course you will find a complete explanation of A.V.C., how to use an oscilloscope, sound feed-back, resonance phenomenon... every possible fact you must know to be the best radio serviceman. You get a real radio training. One of the BEST radio courses is yours for only \$1.95.

#### LIMITED QUANTITY

Hurry your order in today. There is but a small quantity of the courses left at the special bargain price. You are completely protected with the unconditional "you must be satisfied" or money back guarantee.

#### FREE EXAMINATION COUPON

**SUPREME PUBLICATIONS, Agents,**  
3727 W. 13th St., Room 205,  
Chicago, Illinois

Please send the complete R.T.I. radio course at the special reduced \$1.95 price.  
 I am enclosing \$1.95, send prepaid.  
 Send C.O.D. I will pay mailman \$1.95, plus a few cents postage.

NAME .....

ADDRESS .....

Please Say That You Saw It in RADIO-CRAFT



## OPPORTUNITY AD-LETS

Advertisements in this section cost five cents a word for each insertion. Name, address and initials must be included at the above rate. Cash should accompany all classified advertisements unless placed by an accredited advertising agency. No advertisement for less than ten words accepted. Ten percent discount for six issues, twenty percent for twelve issues. Objectionable or misleading advertisements not accepted. Advertisements for January, 1940, issue must reach us not later than November 7th.

Radio-Craft • 99 Hudson St. • New York, N. Y.

### AGENTS WANTED

300% PROFIT SELLING GOLD LEAF LETTERS FOR store windows: Free samples. Metallic Company, 451 North Clark, Chicago.

### BOOKS AND MAGAZINES

WE HAVE A FEW HUNDRED RADIO ENCYCLOPEDIAS, by S. Gernsback, second edition, originally sold at \$3.98. Book has 352 pages, weight 3 lbs., size 9 x 12 inches. Red morocco—keratol flexible binding. Send \$2.49 in stamps, cash or money order and book will be forwarded express collect. Technifax, 1915 So. State Street, Chicago, Illinois.

### CAMERAS & SUPPLIES

BULK FILM: 100 FT. 8MM. \$1.00; DOUBLE. \$1.60; 16 mm. \$1.20. Titles or pictures. Chemicals, outfits. Big catalogue for stamp. Hollywoodland Studios, South Gate, Calif.

GENERA FILM IN BULK FOR ALL MOTION PICTURE cameras, 100 feet for Univex, \$1.00; 100 feet double 8mm. \$1.75; 16mm. \$1.35; 400 feet 16mm. \$4.25, postpaid. Sample for stamp. Process with our prepared powders and simplified outfit: 8mm. \$3.75, 16mm. \$4.95. Fromaders, Davenport, Iowa.

### EDUCATIONAL COURSES

USED CORRESPONDENCE RADIO COURSES AND Technical Books Bought, Sold, Rented, Exchanged, Catalog Free. V. W. Vernon, Henagar, Ala.

CORRESPONDENCE COURSES AND EDUCATIONAL books, slightly used. Sold, Rented, Exchanged. All subjects. Satisfaction guaranteed. Cash paid for used courses. Complete details and bargain catalog FREE. Send name. Nelson Company, M-242 Manhattan Building, Chicago.

PHOTOGRAPHIC RETOUCHERS MAKE GOOD WAGES. "Learn While Earning Method". Multi-Color Studios, San Francisco.

### FOR INVENTORS

CASH FOR UNPATENTED IDEAS. STAMP APPRECIATED. Mr. Ball, 9441-J Pleasant, Chicago.

### FORMULAS

FORMULAS FOR MAKING INSECTIDES, ANTISEPTICS, Bleaching Solutions, Cements for All Purposes, Stain Removing Preparations, Cosmetics, Depilatories, Dyes, Fertilizers, Fire Extinguishing Preparations, Inks, Lacquers, Paints, Plating Solutions, Soaps, Varnishes, Wines and Liquors, and Many Everyday Preparations. Send 10c for each formula. Complete satisfaction or money immediately refunded. L. Feldman, 640 Ramapo Rd., Teaneck, N. J.

### MISCELLANEOUS

MEXICAN LEGAL MATTERS. AMERICAN ATTORNEY. Box 1736, El Paso, Texas.

MONEY BY MAIL—IN AMOUNTS OF \$1.00 TO \$4.00. Plan and sworn statement FREE with 3 months 70-page Mail Order Magazine 25c silver. N. Chapman Pub., Roehl Bldg., Bellingham, Wash.

### RADIO

ANY RADIO DIAGRAM. 25c. SPECIFY MANUFACTURER, model. Radio magazine free. Supreme Publications, 3727 West 13th, Chicago.

WE BUY AND SELL USED RADIO TESTING EQUIPMENT. Time Payments if desired. Harold Davis, Inc., Jackson, Miss.

### STAMPS

JUBILEES, CORONATIONS, SHIPS, WAR, AIRMAILS. Commemorative. Fairley's, Packet 10c. Box 211, Malden, Massachusetts.

### TREASURE LOCATORS

TREASURE FINDER (METAL LOCATOR) CUSTOM built by engineer. Great penetrating power. No fancy gadgets. Uses latest radio developments. Simple, inexpensive to operate. Delivery ten days. See Sept. Radio-Craft article for complete information. Price \$35, ready to use; \$49 complete kit, less wood. A. Stuart, 1015 Wilson Avenue, Teaneck, N. J.

### TECHNICAL ART SERVICE

DESIGN AND ART SERVICE FOR INDUSTRIAL Marketers. We solve your problems on: product and package design, industrial illustrations, technical drawings and diagrams, phantom, cutaway and explanatory drawings, layouts, lettering, photo retouching, displays, industrial cartoons, etc. Wash photos made from blueprints. We excel in airbrush and color work. Complete catalogs illustrated, 100% satisfaction guaranteed. Suggestions and estimates gladly furnished. Rapid delivery on mail orders. Tec-Art Drafting Service, 223 Charlotte Terrace, Roselle Park, N. J.

## EMISSION VS. MUTUAL CONDUCTANCE TEST

(Continued from page 335)

expected. With hundreds of different types of tubes now available it is extremely difficult to get an instrument flexible enough to meet such a wide latitude of requirements. It is therefore usually necessary to use a reasonable number of different potentials and loads representing as near as possible the average of all of the necessary conditions.

One objection is found in the mutual conductance type—that is its limited flexibility. Any changes in the base connections of the various tubes are likely to result in difficulty as far as changes or additions to the instrument are concerned. Likewise the use of some odd combinations of operating voltages will sometimes be difficult to obtain. The probable life of the mutual conductance tester is therefore somewhat lower than with other types, while the price of an accurate instrument is necessarily higher than testers of less complicated design.

### Output Tester

A true output test (See Fig. 3.) is one which determines the power output which a tube is capable of developing without excessive distortion. Its greatest accuracy is in checking power amplifier tubes. This test must also be made under conditions very closely approximating actual operation and is practically a laboratory job. The design is rather difficult to produce at a reasonable price. For that reason most so-called output testers are in reality modified emission types. Obsolescence is likewise apt to occur toward the introduction of new types of tubes. Such additions take place quite frequently and are therefore a condition worthy of consideration.

### Emission Tester

The emission tester is perhaps the simplest and oldest type of tester available. (See Fig. 4.) Probably one of the first methods of tube testing was the measurement of plate current under actual operating conditions. (It was later found that it was not essential to adhere closely to tube specifications in making emission tests.) The filament or cathode is the principal factor determining the condition of a tube, provided the space and size of the element are always the same, with each type of tube.

The only important factor in determining emission is the load applied to the tube. If only a small load is applied to certain types, such as rectifiers, the filament or cathode may be capable of handling that load, and the tube will read "good" although under actual operating load it will fail. Likewise certain battery types and diodes are only capable of good operation under very light loads. If a heavy load is applied to such tubes a perfectly good tube may be damaged. Recent work in conjunction with various tube manufacturers has resulted in the establishment of recommended loads for various types of tubes. These recommendations have been followed closely in the production of certain emission types now on the market. The loading of the tube is all that must be watched for proper emission. With variable loads the test voltages can be kept constant resulting in a relatively simple design in keeping with the space and price limitations existing in dealer requirements.

Early emission tests were found to be somewhat inaccurate due to variations in the structural design of tubes. If the element spacing or position varies, artificial emission readings may be obtained. With present production on precision automatic machines and improved factory inspection,

the chance of irregular design is reduced to a minimum, and it is possible to rely upon indications obtained with a well-designed emission tester.

This article has been prepared from data supplied by courtesy of Weston Electrical Instrument Corp.

Referring to the typical diagrams, on pg. 335, commercial tube checkers employing the mutual conductance principle do not use all of the meters shown in the circuit. Instead, a meter is placed only in the plate circuit; either a D.C. instrument for the grid-shift type or a dynamometer type of A.C. milliammeter for the dynamic mutual circuit. The remaining instruments designated by the letter E, are omitted because it is assumed the voltages are set up properly by controls provided on the panel for that purpose. The output type of circuit is very rarely used because it is limited in its application to certain types of power tubes. In all these circuits the supply voltages and parts values are purely arbitrary, and will vary with the particular type of tube selected as V. The representative tube tester illustrated on the same page is the Weston model 773 portable unit.—Editor

## WAR NEWS VIA RADIO

(Continued from page 329)

point pick-ups during the Austrian Anschluss, from Paris, London, Washington, and New York, but at that time the requirement was restricted to "3-way conversations." During the recent crisis the requirement called for "4-way conversations." Normal arrangements to avoid feedbacks and confusion to the respective commentators would require 8 trans-Atlantic radiotelephone channels to carry 4 voices back and forth. In addition to these, separate cue channels were required for testing and co-ordinating the program. Obviously such a complex and expensive set-up could not be used very often, nor could it be arranged at a moment's notice in an emergency. White turned the problem over to the C.B.S. Traffic and Engineering Departments, and asked them to work out a simpler arrangement of facilities that would produce the same results.

### 4-WAY TALK-FEST

The present "4-way conversation" takes place on only 2 trans-Atlantic point-to-point shortwave channels—one East-bound to Europe, the other West-bound to America. As a usual thing these channels are secured from A.T.&T. The receiving station in Europe relays the East-bound voice from the broadcasting station in America to the European capitals by land wire. The European broadcasters' voices are in turn sent by land-line to the European shortwave transmitter for the West-bound broadcast to America. Here they are received and transmitted to New York and Washington by land-line—making a continuous loop of facilities. (See map.)

Each city on the great trans-Atlantic loop is set up on a conversational basis—that is, the microphones in London, Paris, New York and Washington remain open throughout the duration of the broadcast, as though each were listening in on a "party line." Each broadcaster takes his cue during the program from the preceding speaker, and gives the go-ahead to the man who follows him. With all microphones open, the cities can follow each other in any order desired,

Please Say That You Saw It in RADIO-CRAFT



or all could speak together as in conversation, if need be.

Every effort has been made, in setting up the circuits and amplifiers, to eliminate program interference and feedback. In fact, the circuits are so arranged that though every speaker can hear the voices of his colleagues, he can never hear his own voice—unless he happens to have a set tuned to Columbia's shortwave station WCBX in the studio.

"Cue channels" on direct shortwave between New York and the European capitals are always available in conjunction with these conversations. Over these the traffic department and Paul White generally speak for 5 minutes or so before each broadcast—the traffic department to make certain of transmission results and Paul White to give each speaker the latest war bulletins so that his analysis of news will be up-to-date. The only important European capitals which have no shortwave cue channels are Moscow and Warsaw. On the rare occasions when broadcasts have come from these cities their time schedules have been arranged by cable beforehand and they have come in on an exact time basis.

Striking as the "4-way conversation" may seem to the average radio listener, it is only one of many technical triumphs achieved by the C.B.S. Traffic and Engineering Departments for Columbia's present war coverage. In New York alone the entire set-up of news operations has been changed during the past year, thanks to a number of special devices designed to facilitate the broadcasting of every aspect a news program can include.

**A WAR NEWS STUDIO!**

Columbia's brand new Studio 9 is in itself a major achievement; designed by engineers, and completed just before the war began, it is the only studio in the United States planned exclusively for news broadcasting. Glass-enclosed, so that its staff may be immediately apprised by hand signals of last-minute news bulletins, it is set on the 17th floor in the very heart of the News Department.

Facing one of its glass walls is the glass-enclosed office of Paul W. White, who often directs special news broadcasts from his desk. Another wall faces the glassed-in "news room," where press tickers grind out news bulletins. The news room is equipped with pneumatic tubes through which messages and telegrams can be sent quickly to other departments in the building.

A 3rd wall—also made largely of glass—faces a sound-proof "listening room," where translators listen 24 hours a day to shortwave programs coming from government shortwave broadcast stations in Europe, and jot down news items of importance.

The 4th glass wall of Studio 9 faces a control-booth through which, in time of emergency, all network programs are routed. Thus, when a news bulletin of importance comes through, the technician on duty has only to flip a key switch on his complex control-panel—and instantly all broadcasts on the network are cut off the air, leaving Columbia's roster of 117 stations entirely set up for the news flash.

The studio itself contains the most up-to-date equipment for news broadcasting, with the addition of a very useful gadget invented this year by Columbia engineers—the so-called "Automatic Cue Flash," designed to warn announcers and news analysts at the end of their speaking time.

**THE "AUTOMATIC CUE FLASH"**

The device resembles a battery set on a tray. On either side are 2 red ship's lanterns.  
(Continued on page 383)



**SWINGS INTO ACTION**

Primarily the aim of the Association is to return to the Distributor, the Dealer and the Serviceman the profits which are legitimately HIS! This can only be accomplished by raising the standards of ethics of merchandising within the Industry.

Names of Member Jobbers in your territory will be supplied if you will address the Executive Secretary of the Association.

**TEMPORARY OFFICE OF THE EXECUTIVE SECRETARY**  
5 West 86th Street New York, N. Y.

**PATENTS—TRADE MARKS**

Booklet concerning Inventions & Patents Form "Evidence of Conception" with instructions for use and "Schedule of Government and Attorneys Fees"—Free  
**LANCASTER, ALLWINE & ROMMEL**  
Registered Patent Attorneys  
436 Bowen Bldg. Washington, D. C.

**GOOD MEN IN RADIO JOBS HAVE GOOD**

You need something more than just "good intentions" to qualify for the good jobs in Radio and Television. Today's opportunities go to the men with TECHNICAL TRAINING. Our booklet, "A Tested Plan" tells how YOU can improve your position. Write for your FREE COPY right now to—  
**CAPITOL RADIO ENGINEERING INSTITUTE**  
Dept. RC-12 3224-16th St., N.W. Washington, D. C.

Please Say That You Saw It in RADIO-CRAFT

# FREE- REAL ELECTROPLATING OUTFIT



**Now—  
You Can ELECTROPLATE  
EASILY WITH A BRUSH**

**S**OMETHING new for radio men—something which gives you the opportunity to make additional profits—or to improve your type of service. Here's an ELECTROPLATING KIT amazingly simple to operate—you just Electroplate with a Brush!

## NOT A TOY!

Electroplate for profit, hundreds of things in the household—shtavns, fixtures, water faucets, worn brackets, door knobs, musical instruments, jewelry and silverware and other articles. It's an indispensable piece of equipment—plate articles in hotels, apartments, office buildings, medical and dental offices, factories, schools, laboratories, etc. Exactly the same outfit (but larger) is used professionally by electricians, radio service men, automobile repair shops, etc. Requires one single dry cell 1.2-volt battery to operate.

You can electroplate tarnished receiver parts, escutcheons, contacts, worn radio parts and accessories, and display chassis. Put this REAL ELECTROPLATING KIT to use immediately—make it the most useful article in your shop or laboratory. And you can get it absolutely FREE except for slight mailing costs.

Subscribe today to RADIO-CRAFT for One Year (12 issues) and receive absolutely FREE this REAL ELECTROPLATING KIT. New subscribers are accepted or extend your present subscription twelve months. Mail remittance of \$2.00 plus 10¢ for shipping charge on kit) to the publishers. (Canada and foreign \$2.85). You will receive your FREE, REAL, ELECTROPLATING OUTFIT by return mail. Use coupon below to enter subscription.

## RADIO-CRAFT

99 Hudson Street New York, N. Y.

RADIO-CRAFT RC-1239  
99 Hudson Street, New York, N. Y.

Gentlemen: Enclosed find the remittance of \$2.00 for which enter my subscription to RADIO-CRAFT for One Year (12 issues). Send me FREE, REAL, ELECTROPLATING OUTFIT (Canada and foreign \$2.85). In U. S. add only 10¢ additional to cover shipping charges on kit.

New Subscriber  Extend Present Subscription

Name .....

Address .....

City ..... State .....

(Send remittance by check, money order or unused U. S. Postage stamps. Register letter if you send cash or stamps.)

## NEW "SUPER-PRO" FOR DX-ers

(Continued from page 340)

ing than the other one on the same signal. If one indicates S9 and the other S4 the impression would be that the signal was weaker in one set than the other, which would be true, but actually the transmitter would be sending exactly the same signal to each receiver and the reports would be entirely false. With the Super-Pro the operator merely picks up the average loud signal and adjusts the control so that the S-meter reads whatever he is accustomed to reporting that type of signal and from there on, all other signals are read in proportion to the strength of the signal on which the meter was set.

### TUBE SERVICES

The tube line-up in the new Super-Pro includes two 6K7's as 1st and 2nd T.R.F. amplifiers; 6L7 1st-detector; 6K7 1st I.F. amplifier; two 6SK7's as 2nd and 3rd I.F. amplifiers; 6H6 2nd-detector; 6N7 noise limiter; 6SK7 beat-frequency oscillator; 6SK7 A.V.C. amplifier; 6H6 A.V.C. and meter rectifier; 6C5 1st A.F.; 6F6 2nd A.F.; and two 6F6's push-pull output audio amplifier. The power supply has 2 rectifiers—1 type 5Z3 high-voltage rectifier, and 1 type 80 low-voltage rectifier for the "C"-bias supply.

The 2 carefully-designed tuned R.F. stages result in exceptional sensitivity with a very low background noise level. The gain in the 1st stage is sufficient to override noises originating in the tubes that follow, and the gain in the antenna circuit, or first tuned circuit, is great enough to definitely establish a high signal-to-noise ratio even on the weakest signals. The antenna coil is designed to operate with a low-impedance feeder or lead-in system. The use of low-impedance lead-ins greatly reduces possibility of noise pick-up and provides a simple means for using resonant and directional antenna systems.

Band changing is accomplished by a multi-section can-operated knife switch with silver-plated contacts. No moving parts in this switch carry current and, therefore, there is little danger of this switch becoming noisy or introducing instability.

Changes in I.F. band-width are accomplished by mechanically varying the coupling between the primary and secondary of the I.F. transformers. By means of a control knob on the panel, the operator can adjust the band-width of the receiver to provide highest possible fidelity with a minimum of interference.

Special I.F. transformer design and the use of 3 stages, provide an abundance of amplification with no risk of instability. *Hammarlund engineers have always believed in using one more tube rather than pushing*

a small number of tubes to the limit and thus jeopardizing the overall stability of the receiver.

In the A.F. amplifier, this same practice has been followed. There are 3 stages and the maximum output is approximately 16 watts. The new Super-Pro, of course, has all of the other necessities such as A.V.C., send-receive switch, phone and phono connections, etc., that make the receiver complete in every detail.

The following parts list carries identifying letters and numbers which appear in the diagram shown on pg. 340.

### LIST OF PARTS

(Model SP-200 and SP-200-S Series)

#### INDUCTANCES

##### Antenna Assemblies

- A1, input coil, 10 to 20 mc.;
- A2, output coil, 10 to 20 mc.;
- B1, input coil, 5 to 10 mc.;
- B2, output coil, 5 to 10 mc.;
- C1\*, 20 to 40 mc.;
- C1, input coil, 2.5 to 5 mc.;
- C2\*, 20 to 40 mc.;
- C2, output coil, 2.5 to 5 mc.;
- D1\*, 2.5 to 5 mc.;
- D1, input coil, 1.160 to 2,500 kc.;
- D2\*, 2.5 to 5 mc.;
- D2, output coil, 1.160 to 2,500 kc.;
- E1\*, 1,250 to 2,500 kc.;
- E1, input coil, 540 to 1,160 kc.;
- E2\*, 1,250 to 2,500 kc.;
- E2, output coil, 540 to 1,160 kc.

#### R.F. Assemblies

- F, 1st coil, 10 to 20 mc.;
- G, 1st coil, 5 to 10 mc.;
- H\*, 20 to 40 mc.;
- H, 1st coil, 2.5 to 5 mc.;
- J\*, 2.5 to 5 mc.;
- J, 1st coil, 1.160 to 2,500 kc.;
- K\*, 1,250 to 2,500 kc.;
- K, 1st coil, 540 to 1,160 kc.;
- L, 2nd coil, 10 to 20 mc.;
- M, 2nd coil, 5 to 10 mc.;
- N\*, 20 to 40 mc.;
- N, 2nd coil, 2.5 to 5 mc.;
- P\*, 2.5 to 5 mc.;
- P, 2nd coil, 1.160 to 2,500 kc.;
- R\*, 1,250 to 2,500 kc.;
- R, 2nd coil, 540 to 1,160 kc.

#### I.F. Assemblies

- S, osc. coil, 10 to 20 mc.;
- T, osc. coil, 5 to 10 mc.;
- W\*, 20 to 40 mc.;
- W, osc. coil, 2.5 to 5 mc.;
- X\*, 2.5 to 5 mc.;
- X, osc. coil, 1.160 to 2,500 kc.;
- Y\*, 1,250 to 2,500 kc.;
- Y, osc. coil, 540 to 1,160 kc.;

#### Other Assemblies

- T1, crystal filter (465 kc.);
- T2, T3, 1st and 2nd I.F. transformer coil;
- T4, detector plate coil;
- T5, beat-oscillator coil;
- T6, A.V.C. plate coil.

#### CONDENSERS

- 2, 12, 22, 106, 107\*, mica, 600 mmf.;
- 28, silver, 95 mmf.;
- 34, silver, 50 mmf.;
- 77, mica, 50 mmf.;
- 9, 19, 69, tubular, 0.02-mf., 500 V.;
- 4, 11, 24, tubular, 0.01-mf., 500 V.;
- 7, 17, 30, 36, 43, 46, 48, 51, 56, 58, 61, 63, 73, 85, 92, tubular, 0.05-mf., 500 V.;
- 40, 101, 102, tubular, 0.25-mf., 400 V.;
- 88, dry electrolytic, 40 mf., 150 V.

\*Used in SP-200-S Series only.

(Continued on page 380)

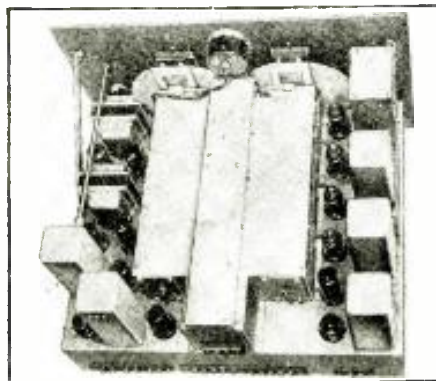

Rear view of the latest Hammarlund "Super-Pro" Communications Receiver.

Please Say That You Saw It in RADIO-CRAFT



**OPERATING NOTES**

(Continued from page 352)

Current turned on anywhere in house would raise the volume. A new volume control eliminated the trouble.

J. O. ROBERTS,  
Roberts Radio Service,  
St. Louis, Mich.

**LAFAYETTE D-40**

This receiver, a 6-volt all-wave superhet., came into the shop last week. Trouble: Blasting on powerful stations.

Checking the A.V.C. circuit, it was found that the lower connection of the secondary of the 1st I.F.T. had been connected directly to ground at the factory, instead of being connected to the A.V.C. line. The company's service diagram, however, shows this connection properly made to the A.V.C. line.

Connecting the transformer to its proper place entirely cured the trouble.

JEAN-PAUL MARCOTTE,  
Amos, Quebec, Can.,  
P. O. Box 271.

**CHEVROLET 1939 CAR-RADIO, PUSH-BUTTON MODEL 985283**

This set tunes with a manual control; and also with pushbuttons operating an electric motor located inside the case. The set works OK with manual control, but when push-buttons are used the fuses blow.

After wasting a good deal of time I found the trouble located in the 6 V. leads running to the tuning motor. These leads were lying against the relay that shuts off the motor when the stations are tuned-in. The movement of the relay rubbed-through the insulation and caused the "A"-hot lead to short to the motor. I have found 6 of these sets with this trouble in the last 2 months.

ALBERT YOUNG, JR.

**CROSLY 156**

In the past year or so I have serviced several Crosley model 156 radio sets. In each case the set was inoperative.

Upon investigation it was found that the set contained a vitreous-type voltage divider with 2 sections. The ohmic value of the section nearest ground which carries the bleeder current was in every case correct but the section nearest the high-voltage end was in every case of the order of a megohm. Replacing the entire resistor or simply the high-voltage section by a 2-watt wire-wound resistor solved the problem.

I have found this type of resistor burned-out in several other types of Crosley receivers due apparently to a too-low watts rating.

CAPT. E. B. GARLAND,  
Signal Corps, U.S.A.

**STEWART-WARNER 01-6B9**

—Reducing Needle Scratch

If you should receive a complaint that there is excessive needle scratch during phonograph operation of the Model 01-6B9, check the phonograph pickup connections at the "PHONO-RADIO" switch under the top panel as described below:

(1) First samples of this receiver had a 220,000-ohm resistor across the pickup connections. In these sets, remove the 220,000-ohm resistor and connect a 68,000-ohm resistor (or 70,000 ohms, if no 68,000-ohm unit is available) across the pickup. Then connect a 0.003-mf. condenser across this shunt resistor.

(2) A few sets had the 68,000-ohm resistor connected across the pickup, but no

**YOU NEED BOTH THESE GHIRARDI SERVICING AIDS**



**Use them to cut down your working time on every job**

**The PRACTICE** **The THEORY**

**RADIO Trouble-Shooter's HANDBOOK** **MODERN Radio SERVICING**

Save your TIME!—It's your bread and butter! Stop fiddling and fussing with balky sets! Eliminate guesswork; throw out your old tip-files! Here in one handy reference manual is all the dope you need to get right to the bottom of most any trouble-shooting problem. Here's tried and proven Case History data on 3,313 receivers—and for each set you get time-saving suggestions on where to locate every common trouble and what to do about it. All kinds of other useful data, too. Just what every service man has wanted—ready for instant use on every job. You'll make money with this book—it's the greatest time-saver on your bench! Don't go another day without it—clip and mail the coupon at once!

**3,313 CASE HISTORIES**

- Case Histories—Trouble Symptoms and Remedies for 3,313 sets, compiled from actual Service Records. By far the world's largest and most authentic Case History compilation.
- I.F. Peaks—Over 15,000 Listings for Alignment of all Superhets, old and new.
- Auto-Ratio—Gear Ratios and Dial Directions of Tuning Controls of all sets; Installation and Car-Ignition Systems Data for all cars; Special Interference Elimination Instructions; Electrical Wiring Diagrams, etc.
- Other Data—Over 100 more pages of data, including Quick Trouble-Shooting Charts; Servicing Home Recorders; Servicing Inter-communicators; Trade Directories; Charts & Tables on Tubes, Filters, Transformers, etc.

**518 PAGES. 134 Illustrations. (8½ x 11) Standard Manual Size. Fabricoid-bound. \$3.**

**Here's a Sample of What You Get!**

- Test Equipment—420 pages of Theory, Descriptions, Diagrams of all Commercial Instruments, Construction Data, etc.
- Trouble-Shooting—254 pages of newest short-cut methods for tracking down all types of different receiver troubles.
- Repairing—184 pages of advanced "factory methods" for Superhet Alignment, Interference Elimination, Repairing all sets, etc.
- Special Problems—422 PAGES on Auto-Radio Servicing and Installation; Servicing All-Wave Sets, High Fidelity Sets, AVC and QAVC circuits; Selling and Advertising; etc.

**1300 PAGES. 706 Illustrations. 720 Review Questions. 766 Topics. \$4.00.**

**Use them 5 days—OUR RISK!** **\$6.50 For BOTH BOOKS**

**RADIO & TECHNICAL PUBL. CO., Dept. RC-129**  
45 Astor Place, New York

Enclosed find payment for, and rush to me postpaid with 5-Day Money-Back Guarantee:

- MODERN RADIO SERVICING at \$4. (\$4.50 foreign)
- RADIO TROUBLE-SHOOTER'S HANDBOOK at \$3. (\$3.50 foreign)
- BOTH BOOKS \$6.50 Special "Combination Price" (\$7 foreign)

Please send me FREE descriptive literature.

NAME \_\_\_\_\_  
ADDRESS \_\_\_\_\_  
CITY \_\_\_\_\_  
STATE \_\_\_\_\_

0.003-mf. condenser. In these sets add the 0.003-mf. condenser across the pickup connections.

(3) Most sets will have a 68,000-ohm resistor and a 0.003-mf. condenser connected across the pickup. These sets should not be changed but if there is excessive needle scratch, make sure the 0.003-mf. condenser is not open-circuited.

(4) Some sets using a slightly different pickup have a 470,000-ohm resistor and a 0.001-mf. condenser connected across the pickup. These should not be changed although a slightly larger condenser would cut the high notes more and such a condenser could be used if the customer prefers the tone quality with the larger condenser.

**IMPORTANT**—If there is any "growling" during phonograph operation, be sure the chassis hold-down bolts are loosened sufficiently to permit the radio chassis to float on its rubber cushions. Also, if it is a very early chassis, make the change described in No. 1, above. If this does not remove the growl replace the 22,000-ohm resistor connected to the tap of the volume control with a 47,000-ohm resistor.

M. J. SCHINKE,  
Service Department,  
Stewart-Warner Corp.

**NEXT MONTH**—How to make a home-made dynamic tester for servicing receivers. Reserve your January, 1940, issue today.

Please Say That You Saw It in RADIO-CRAFT

**DATAPRINTS**

- TESLA-ODIN HI-FREQ. COILS**
- 20c Ea. in order for 10 (Data and Drawings only.)
- 36" Sp'k Tesla-Oudin Coil 40c (1 K.W. Exc. Trf. Data. included FREE!)
- 8" Sp'k Tesla-Oudin Coil 40c (¼ K.W. Exc. Trf. Data. included FREE!)
- 3" Sp'k Oudin; 110 Vt. "Kick Coil" type.....40c
- 3" Sp'k Tesla Works on Ford Sp'k Coil.....40c
- 1" Sp'k Violetta Hi-Freq. Coil.....40c
- Model Warships—Get List of Plans



**Induction PIPE & ORE LOCATOR**  
Construction Data.....40c

**YOU need these DATAPRINTS!**

- 5 Meter Superhet. Resistance Measuring
- 1½ Meter Tr. & Rec. Bridge
- 20 A.C. Probs. & Ans. Weld. Transf. 2 K.W.
- 20 Telephone Hook-ups Rewinding Armatures
- 100 Mech. Movements String Galvanometer
- 20 Motor Hook-ups 20 Simple Bell Circuits

Special Prices: 4 prints \$1.00; 10 for \$2.00; Single. 40c each. Get New Catalog 100 A.

**The DATAPRINT Co.**  
Lock Box 322C, Ramsey, N. J.



FREQUENCY-MODULATED PROGRAMS

(Continued from page 337)

Get This Attractive  
**DESK LAMP**  
Absolutely FREE

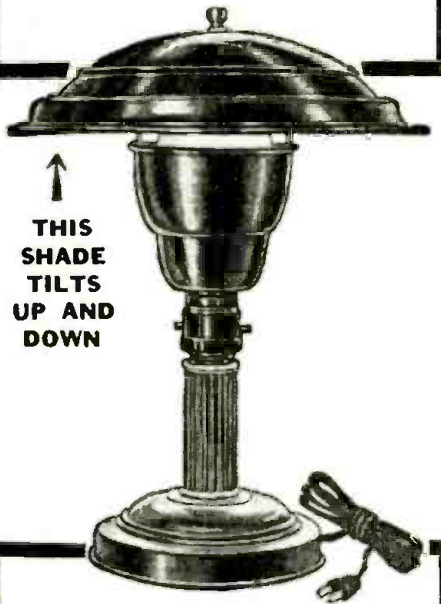

↑  
**THIS SHADE TILTS UP AND DOWN**

**JUST THINK OF IT**—you can get absolutely FREE, the beautiful desk lamp which is shown above. This lamp is suitable for home, desk, den, office, laboratory, studio or workshop. It is sent to you by the publishers for a one-year subscription to RADIO-CRAFT.

**Here Are The Lamp Features!**

- Constructed of metal with attractive bronze finish.
- Scientifically constructed to give glareless, diffused light.
- Helmet-type shade can be tilted to any convenient angle.
- Stands 13" high and has 10" metal shade.
- 5-foot rubber insulated cord and plug.
- Constructed to last for many years.

**Clip Coupon — and Mail!**

Send your subscription to RADIO-CRAFT for One Year (12 issues) and receive absolutely FREE one of these remarkable desk lamps. New subscribers are accepted or you may extend your present subscription another twelve months. Mail your remittance of \$2.00 (Plus 25c for shipping charges on lamp) to the publishers. (Canada and foreign \$2.75.) You will receive your FREE DESK LAMP by return mail. Use coupon below to enter your subscription.

**RADIO-CRAFT**

99 Hudson Street NEW YORK, N. Y.

**RADIO-CRAFT**

99 HUDSON STREET, NEW YORK, N. Y.

Gentlemen: Enclosed you will find my remittance of \$2.00 for which enter my subscription to RADIO-CRAFT for One Year (12 issues). Send me my FREE DESK LAMP. (Canada and foreign \$2.75.) In U. S. add 25c additional to cover shipping charges on lamp.

- NEW SUBSCRIBER
- EXTEND PRESENT SUBSCRIPTION

Name .....

Address .....

City ..... State .....

(Send remittance by check, money order or unused U. S. Postage stamps. Register letter if you send cash or stamps.)

RC-1239

able of producing audio voltages whose frequencies are proportional to the rate of frequency change of the received R.F. signal; and whose magnitudes are proportional to the amount of frequency change.

There are several types of limiter and detecting circuits which may be utilized, but probably the simplest and most effective is a limiter circuit consisting of a sharp cut-off tube and a resistor in series with the grid of this tube developing a negative bias which is applied to other I.F. amplifier tubes.

For the detecting system, an I.F. transformer somewhat similar to that used for the discriminator of an automatic-frequency-controlled receiver may be readily employed, for the circuit is so arranged that if the intermediate frequency varies, a voltage is developed across a resistor in the cathode circuits of a 6H6 rectifier tube.

The limiter and detecting systems are shown schematically in Fig. 5. It might be pointed out in passing that the adjustment of the I.F. transformer feeding the 6H6 is quite critical if good quality reception is to be obtained.

It is gratifying to note that numerous commercial stations are being erected and put into operation. (See tabulation, at the end of this article, which lists all the high-frequency F.M. and A.M. stations.—Editor)

A few other stations are transmitting and there is a considerable number which have been granted licenses and will shortly be in the process of construction. Thus the eastern part of the United States should be well served with high-quality frequency-modulated transmission. In rural districts and in places where there are no local broadcasting stations, frequency modulation will be a great boon to the radio listeners for practically noiseless reception is assured at all times.

**"WIDE-BAND" F.M.**

Pioneering regular broadcast service with frequency modulation is the development of the Yankee Network in New England, where John Shepard, 3rd, President of The Yankee Network is building at Paxton a 50,000-watt frequency modulated transmitter to operate on the frequency of 43 megacycles. The station has been in operation 16 hours daily for over 2 months, utilizing the present installed capacity of transmitting equipment of about 2,000 watts. Equipment to permit operation with full 50,000 watts will be completed and in operation in about 6 months.

In addition, The Yankee Network is pioneering in the relaying of broadcast programs from its studios to the main transmitter by means of a Frequency-Modulated Relay Station. This Relay Station, with call letters WEOD, operates on a frequency of 133,030 kilocycles (133 mc.) The transmitter is located atop the studio building in Boston and transmits the program to the main transmitter at Paxton, an airline distance of 43 miles, where the programs are received and rebroadcast.

This circuit has been in continuous operation since May, and has rendered service free from interference and distortion without interruption since then. Tests of the coverage of the main transmitter at Paxton, which operates under the call letters WIXOJ, indicate that with the present power of approximately 2 kilowatts, interference-free service is obtained for a radius of 50 miles and more under all conditions.

It should be noted that the demonstrated results of the experimentation by The Yankee Network are the result of the application of Major Armstrong's system of

wide-band Frequency Modulation and are not inherent in the use of Frequency Modulation per se.

**DYNAMIC RANGE; INTERFERENCE**

If a large dynamic range is to be had in frequency modulation transmission, the bandwidth necessary may be 100 kc. or more either side of the carrier. Obviously such bandwidths can not be obtained on present broadcast channels and it is necessary for frequency modulation transmission to resort to high frequencies where there is available space in the ether. Most frequency transmissions are thus around 7 meters (between 39 and 44 mc.).

When listening to frequency modulation transmissions, the *dynamic range* is very apparent. That is, the program may go from the lowest (volume) to the loudest passages of an opera with the same clearness and fidelity. Complete absence of interference is also very apparent especially during times of intense static when shortwave amplitude-modulated stations are completely blotted out. There seems to be very little fading. This may not be entirely due to the method of transmission but partly because of the frequency of transmission. Utilizing a well-designed receiver, a few microvolts signal is all that is necessary for good reception.

There can be no interference from one station to another such as encountered in amplitude-modulated signals! If 2 frequency modulation stations some distance apart were to transmit on the same frequency and if a frequency modulation receiver were gradually moved between the 2 stations, either one or the other would be heard. There might be a "no man's land", so to speak, where the program of one station and then the program of the other station would be heard, but there would be no interference as we know it.

It would appear that frequency modulation will, in the years to come, come into its own and in a large measure supersede the present method of shortwave transmission. It certainly has in its favor program enjoyment which can not be obtained by the older methods.

*This article has been prepared from data supplied by courtesy of Browning Laboratories, Inc.*

Technicians may wish to refer to one of the following published articles:

- (1) "A Method of Reducing Disturbances in Radio Signaling by a System of Frequency Modulation," Edwin H. Armstrong, *Proc., I.R.E.*, Vol. 24, No. 5, May, 1936.
- (2) "New Ears for Your Radio Set and New Fortunes in Radio," *Ken*, June 29, 1939.
- (3) "Revolution in Radio," *Fortune*, October, 1939.
- (4) "Science Tunes in a New Kind of Static-Free Radio Service," *Science News Letter*, June 10, 1939.

In order that radio Servicemen may have a practical, commercial circuit embodying the principles discussed by the authors, *Radio-Craft* has supplied the illustration and circuit of the G.E. HM-80 F.M. receiver. To complete this reference material for Servicemen the following additional information is given.

**I.F. ALIGNMENT**

Due to the good stability of components and the wide-band characteristics of the I.F. circuits, alignment should be unnecessary under normal operating conditions. Should I.F. alignment become necessary, it will require a cathode-ray oscilloscope and

Please Say That You Saw It in RADIO-CRAFT



a 2.1 megacycle signal generator with a superimposed  $\pm 300$  kc. sweep frequency.

This generator may be made by constructing an oscillator with the tank condenser semi-fixed and variable, the variable portion being designed to rotate with a motor and of proper capacity to give  $\pm 300$  kc. variation of the 2.1 megacycle mid-frequency. (See "Home-Made Frequency Modulator," Oct., 1939, *Radio-Craft*.—Editor) Connect the vertical plates of the oscilloscope across resistor R10 and align transformers L5, L4 and L3 progressively. A 2 mh. choke should be connected in series with the high side of the oscilloscope.

With the same oscillator and sweep signal as used above, connect the vertical oscilloscope plates across resistors R11 and R12. Align transformer L6 for an x-shaped crossover curve. Proper alignment of C13 is indicated when the curve crosses about midway in the vertical plane. Proper alignment of C12 is indicated when the sides of the curve near crossover are nearest to a straight line.

Note: Keep signal input high enough so that noise limiter is functioning. This point is indicated when an increase in signal input no longer changes the size of the curve.

**R.F. ALIGNMENT**

Make sure the dial pointer coincides with the first division on the low-frequency end of the dial scale when the gang condenser is completely closed.

(1) Connect a 0-50 or 0-100 microamp. meter in series with the low end of R10. A high-resistance, 0-10 V., D.C. voltmeter may be used instead of the microammeter. Connect the voltmeter across R10 with a 2 mhy. choke in series with the high side.

(2) Apply an unmodulated signal in the region of 43 megacycles to the antenna.

(3) Adjust pointer so it is set to the scale mark of the signal used and peak trimmers C36 and C35, in this order, for maximum meter reading.

It is believed that the following list of A.M. and F.M. stations will prove not only interesting to technicians generally, but will be especially useful to Servicemen who may have occasion either to install or service amplitude- or frequency-modulated receivers operating in the high-frequency region above about 25 megacycles (or below about 12 meters).

**HIGH-FREQUENCY BROADCAST STATIONS**

Corrected to Oct. 3, 1939; see pg. 351 for additional listings.

Federal Communications Commission, Washington, D. C.

(Amplitude Modulated and, in italics, Frequency Modulated Stations)

LICENSEE AND LOCATION	CALL LETTERS	FREQUENCY (KC.) OR GROUPS	POWER RATING
<i>Edwin H. Armstrong, North of Alpine, N. J.</i>	W2XJN	42,800 117,430	100W.
E. Anthony & Sons, Inc., Fairhaven, Mass.	W1XEQ	42,300	100W.
Bamberger B'dc'st'g Service, Inc., New York, N. Y.	W2XJ1	25,300	100W.
A. H. Belo Corp., Dallas, Texas	W5XD	25,300	100W.
City of New York. Municipal B'dc'st'g System, New York, N. Y.	*W2XV1	26,100	1KW.
C.B.S., New York, N. Y.	W2XDV	42,300	50W.
C.B.S., Los Angeles, Calif.	W6XDA	42,300	100W.
C.B.S., Minneapolis, Minn.	W9XHW	42,300	50W.
The Crosley Corp., Cincinnati, Ohio	W8XNU	25,950	1KW.
Everett L. Dillard (Comm'l Radio Equipment Co.) Kansas City, Mo.	W9XA	26,000	1KW.
The Evening News Assn., Detroit, Michigan	W8XWJ	42,060	500W.
General Electric Co., Schenectady, N. Y.	W2XDA	43,200	50W.
General Electric Co., Albany, N. Y.	W2XOY	43,200	150W.
William G. H. Finch, New York, N. Y.	W2XWF	42,180	1KW.
Head of the Lakes B'dc'st'g Co. Superior, Wis.	W9XJL	26,100	250W.
Head of the Lakes B'dc'st'g Co., Superior, Wis.	*W9XYH	43,000	1KW.
John V. L. Hogan, L. I. City, N. Y.	*W2XQL	**43,200	1KW.
C. M. Jansky, Jr., & Stuart L. Bailey (Jansky & Bailey), Georgetown, D. C.	*W3XO	43,200	1KW.
The Journal Co., The Milwaukee Journal, Milwaukee, Wis.	*W9XAZ	42,260	500W.
KLZ B'dc'st'g Co., Denver, Colo.	W9XLA	25,400	100W.
Knickerbocker B'dc'st'g Co., Inc., Flushing, N. Y.	W2XQO	25,550	100W.
Ben S. McGlashan, Los Angeles, Calif.	W6XKG	25,950	1KW.

(Continued on page 381)

Please Say That You Saw It in RADIO-CRAFT

*Servicemen!*  
**MAKE MORE MONEY**  
*renting*

**LAFAYETTE P.A.**

Every special event in your area is an opportunity for you to make money today renting and installing sound systems. The auto show, prize fight, football game, political campaign—these are just a few of the pressing needs for P.A. Cash in on them all with Lafayette—the P.A. line that costs less to own.



**EASY TO BUY.** Lafayette offers a complete line of modern sound systems priced surprisingly low. Because they pay for themselves more quickly, because they're outstanding in dependability, outlasting many units that cost twice the money, your profits are greater with Lafayette. Send today for new FREE 1940 catalog. See this amazing P.A. line, note the features, and the prices.

**Radio Wire Television Inc.**  
formerly WHOLESALE RADIO SERVICE, INC.

NEW YORK, N.Y. • CHICAGO, ILL. • ATLANTA, GA.  
100 SIXTH AVENUE • 701 W. JACKSON BLVD. • 245 PEACHTREE ST.  
BOSTON, MASS. • BRONX, N.Y. • NEWARK, N. J. • JAMAICA, L. I.

**LAFAYETTE** PUBLIC ADDRESS EQUIPMENT

Radio Wire Television Inc.  
Dept. 3MP9 - 100 Sixth Ave., New York.  
Rush FREE Lafayette Catalog No. 78.

NAME \_\_\_\_\_  
ADDRESS \_\_\_\_\_  
CITY \_\_\_\_\_ STATE \_\_\_\_\_

PASTE COUPON ON PENNY POSTCARD

**Meissner Analyst**  
**\$60 Net. Complete Kit**



**AUDIO**  
50-50,000  
CYCLES  
**VOLTMETER**  
5, 15, 50, 150,  
500 VOLTS  
**OSCILLATOR**  
0.6 to 15.0 MC.

**RF - IF**  
95 to 1700 KC.

**LINE CURRENT**  
0.1 to 3.0 AMP.

THE MEISSNER ANALYST is a highly efficient new "trouble shooter," easy to read and operate. It will take the kinks out of your toughest servicing problems . . . save valuable time . . . increase your profits.

See the ANALYST at your Parts Jobber's— or mail coupon for FREE FOLDER. It tells the whole story. Ask about time payments.



MEISSNER MFG. CO. Dept. RC-12  
Mt. Carmel, Ill.

Send Folder on the Meissner ANALYST  
 Also your complete '39-'40 CATALOG

Name \_\_\_\_\_  
Address \_\_\_\_\_

# PRICED FOR CLEARANCE!

Rockbottom Prices on Overstocked New and Rebuilt Merchandise

When prices are low we buy! They're low now—LOWER THAN THEY EVER WILL BE—hence this sale. Most of the merchandise is new—never used; some of it reconditioned. 100% satisfaction on each transaction or your money refunded. ORDER FROM THIS PAGE. Use the convenient coupon below. Be sure to include sufficient extra remittance for parcel post charges, else the order will be shipped express, charges collect. Any excess will be refunded. C.O.D. shipments require a 20% deposit. If full remittance accompanies order deduct 2% discount. Send money order—certified check—new U. S. stamps. No C.O.D. to foreign countries.

ORDER TODAY QUANTITIES LIMITED PROMPT SHIPMENTS ASSURED

### WESTINGHOUSE WATTHOUR METER

Completely overhauled and ready for immediate service. Designed for regular 110-volt, 60 cycle 2-wire A.C. circuit. Servicemen use it in their shops to check current consumption of sets, soldering irons, etc. Keeps costs down. If dismantled the parts alone would bring the price. The elaborate gear train could be used as a counter on machines of various kinds. Simple to install: 2 wires from the line and 2 wires to the load. Sturdily constructed in heavy metal case. Size: 8 1/2" high, 6 1/4" wide, 3" deep, overall. Spp. wt. 1 1/2 lbs.



ITEM NO. 16  
Your Price ..... \$4.50

### PORTABLE TELEGRAPH AND BUZZER FIELD SETS



Made for military use by Western Electric. A wonderful buy if only for the parts it contains. Never been used. Good for code practicing, signaling, communications, etc. Contains 2-tone, high-frequency buzzer with platinum contacts, telegraph key, telephone switches, earphone, condensers, transformers, chokes, etc. A \$50 value easily. Complete in wooden case with diagrams and instructions. Spp. Wt. 12 lbs.

ITEM NO. 16  
Your Price ..... \$5.45

## SERVICEMEN! — EARN MORE MONEY

Electrifying Domestic Sewing Machines

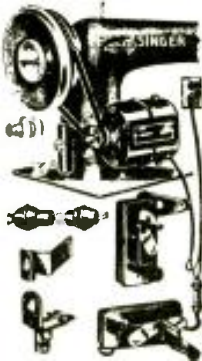

While you're repairing that radio suggest electrification of the old sewing machine. The cost is amazingly low. Every "foot-treadle" housewife is a likely prospect. Only one hole drilled to mount the entire assembly. Labor cost low, profit high.

#### COMPLETE EQUIPMENT SUPPLIED

Nothing else to buy. Kit includes motor, bracket to fit any machine (mention name), cord, pulley and rheostat for knee or foot control. Motor is 1/20 HP, 110 volts AC or DC, 25 or 60 cycles, 5,000 RPM variable, double 1/4" shaft for either rotation, flat-sided case to permit use on drop-head machines. Size 5" x 3" x 2 1/4". Ship. Wt. 16 lbs.

ITEM NO. 37  
Your Price ..... \$8.65

## WELDING! BRAZING! SOLDERING!

### 3-IN-1 PORTABLE ELECTRIC TORCH

WORKS FROM 110 VOLTS A.C. OR D.C. LINE

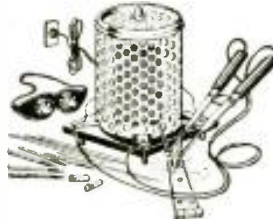

This electric torch is not a gadget or a toy but a sturdily built outfit using the finest materials. With it you are able to do professional type of welding, brazing and soldering work, regardless of whether or not you've had previous experience. It will do a thousand and one jobs: fender welding, auto body repairs, bumpers, cylinders, tanks and industrial repairs—ideal for steel filters, plumbers, sheet metal jobs, engineers, maintenance men, radio and bicycle repair men, etc. Works on aluminum, brass, copper, iron, steel and other metals.

The 3-in-1 electric torch is so simply constructed that even a boy can operate it after reading the simple and concise instructions furnished with the unit. Not necessary to know how to strike an arc! All you do is plug the torch into the light socket, adjust the carbons per instructions, and presto!—you have an intense, blazing flame, ready for work. The outfit comes complete with power unit, electric cord, electrode holder, carbons, welding rods, blazing rods, solder flux, goggles, and instructions.

Save money! Do your own repairing. Earn money by doing repairing for others. Simple, practical, durable and safe to handle—that's why the price is amazingly low. Don't delay—order one today. Ship. Wt., 8 lbs.

ITEM NO. 50  
Your Price ..... \$6.95

### WESTON MODEL 562 A.C.—D.C. AMMETER

Designed by Weston for the Eastman Kodak Co. Range, 0 to 6 Amps. It is a precision-built magnetic-vane type ammeter which, with suitable shunts, can be made to measure heavier currents too. It is 2" in diameter and designed for panel mounting. Bakelite base and black-enamelled cover. Ship. Wt. 2 lbs.



ITEM NO. 35  
Your Price ..... \$1.25

### 1/20 HP 2-SPEED AC-DC MOTOR

Double-Shaft, 5000 and 230 RPM

Brand new back-gear motors. Never been used. Steel worm and fibre driven gears. The 230 RPM shaft is at right angles to main shaft and delivers power up, down, right or left by moving gear train. A suitable-sized rheostat may be used for controlling the speed. Shaft is 3/16". For 110-volt A.C. or D.C., 25 or 60 cycles. Servicemen and others will find the double speeds useful for grinding, buffing, winding coils. Ship. wt. 12 lbs.



ITEM NO. 40  
Your Price ..... \$5.25

### 1/100 HP AC MOTOR

Excellent for experimenting, mechanical toys, dynamic window displays, etc. Develops 1750 RPM. Has 2-sided shaft with fan blade on one end for cooling the motor. Housed in sturdy case with attached mounting bracket. Ship. Wt. 5 lbs.



ITEM NO. 41  
Your Price ..... \$1.49

### MOTOR-SPEED REDUCER

Reduces the speed of electric motors 12 1/2 times. The gears are totally enclosed in a steel case. Shaft, 1/2", sleeve bearings 2 3/4", shaft extension 3 3/4". Base to shaft centers 7". High speed shaft on top. Mounting bolts 3/16" x 2 3/4". Ship. Wt. 8 lbs.



ITEM NO. 42  
Your Price ..... \$4.72

WE HAVE NO CATALOG. ORDER FROM THIS PAGE.

HUDSON SPECIALTIES CO. - 40-R West Broadway - N. Y. C.

IT'S EASY TO ORDER — CLIP COUPON — MAIL NOW

HUDSON SPECIALTIES CO., 40-R West Broadway, New York, N. Y. RC-1239

I have circled below the numbers of the items I'm ordering. My full remittance of \$ ..... (include shipping charges) is enclosed.

OR my deposit of \$ ..... is enclosed (20% required), ship order C.O.D. for balance. (New U.S. stamps, check or money order accepted.)

Circle Item No. wanted: 16 33 35 37 40 41 42 50

Name ..... Address .....

City ..... State .....

Send remittance by check, stamps or money order; register letter if you send cash or stamps.

## NEW "SUPER-PRO" FOR DX-ers

(Continued from page 376)

### RESISTORS

- (W.—wire-wound; M.—metallized)
- 80, 4 ohms, W.—W., 5 watts;
- 89, 750 ohms, W.—W., 10 watts;
- 11\*\*, 21\*\*, 20 ohms, W.—W., 1/2-watt;
- 96, 300 ohms, M., 1/2-watt;
- 98, 1,700 ohms, M., 1/2-watt;
- 10, 20, 44, 6, 47, 49, 57, 59, 16, 2,000 ohms, M., 1/2-watt;
- 99, 3,000 ohms, M., 1 watt;
- 86, 5,000 ohms, M., 1/2-watt;
- 5, 15, 25, 50, 60, 10,000 ohms, M., 1/2-watt;
- 37, 12,000 ohms, M., 2 watts;
- 29, 25,000 ohms, M., 2 watts;
- 35, 26, 66, 84, 50,000 ohms, M., 1/2-watt;
- 64, 72, 93, 50,000 ohms, M., 1 watt;
- 65, 75,000 ohms, M., 1/2-watt;
- 78, 0.25-meg., M., 1/2-watt;
- 3, 13, 23, 70, 74, 83, 0.5-meg., M., 1/2-watt;
- 53, 2 megs; M., 1/2-watt;
- 54, sensitivity control, 50,000 ohms;
- 68, audio gain control, 0.25-meg.;
- 110, meter-adjusting potentiometer, 1,000 ohms, W.—W.

### TUBE SOCKETS

- 8, 18, 45, 6K7;
- 55, 62, 91, 6SK7;
- 76, 95, 6H6;
- 79, 6N7;
- 81, 6SJ7;
- 71, 6C5;
- 75, 87, 90, 6F6;
- 27, 6L7;
- 42, 6J7.

### Misc.

- 32, 33, 38, dial and meter lamps, 6.3 volts, .15-amp.;
- 94, tuning meter;
- 100, off-on switch;
- 52, 103, A.V.C. manual and speaker-phones switch;
- 41, C.W.-mod. switch;
- 31, send-recv switch;
- 67, limiter switch;
- 17, push-pull input transformer;
- T8, push-pull output transformer;
- 1, antenna terminal strip;
- 108\*, 109\*, R.F. choke;
- 39, relay terminal strip;
- 104, phono-speaker-phones terminal strip;
- 105, connecting terminal strip.

\*Used in SP-200 Series only.

## NEW CIRCUITS IN MODERN RADIO RECEIVERS

(Continued from page 338)

type 6A7 as in Fig. 2A. The antenna is permanently coupled to both input circuits and one detector or the other is thrown out of service simply by opening its cathode circuit. Switch Sw. 1 accomplishes this change-over. The detector plates are in parallel, only one being used at a time. The individual circuits are otherwise conventional.

### (4) LINK COUPLING USED IN VIDEO AMPLIFIER

Andrea Models 1F5 and KTE-5. For a wide-band high-frequency video amplifier, link coupling has certain characteristic advantages.

Several of the video stages are coupled as in Fig. 2B. Any attempt of the amplifier to favor the resonant or center frequency is off-set by greater absorption of energy by the link circuit. The separate tuned link circuit is not actually coupled to the transformer secondary except by way of the primary. As its resonant frequency is ap-

(Continued on following page)



HIGH FREQUENCY BROADCAST STATIONS

(Continued from page 379)

Ben S. McGlashan, Los Angeles, Calif.	W6XRE	42,300 116,950 350,000	500W.
Memphis Comm'l Appeal Company, Memphis, Tenn.	W4XCA	26,150	250W.
Midland B'dc'st'g Co., Inc., Kansas City, Mo.	W9XER	42,460	500W.
N.B.C., Bound Brook, N. J.	W2XDG	42,420	150W.
N.B.C., New York, N. Y.	W2XHG	42,060	150W.
Nat'l Life & Accident Insurance Co., Inc., Nashville, Tenn.	W4XA	26,150	1KW.
The Pulitzer Pub. Co., St. Louis, Mo.	W9XPD	25,900	100W.
Radio Air Service Corp., Cleveland, Ohio	W8XNT	42,340	50W.
K. E. Schonert, Schonert Radio Service, Harrisburg, Ill.	W9XTA	26,000	500W.
South Bend Tribune, South Bend, Ind.	W9XH	26,050	100W.
The Star-Times Pub. Co., St. Louis, Mo.	W9XOK	25,300	100W.
Travelers B'dc'st'g Service Co., Avon, Conn.	W1XEH	42,460	150W.
WCAU B'dc'st'g Co., Philadelphia, Pa.	W3XIR	42,140	100W.
WDOD B'dc'st'g Corp., Chattanooga, Tenn.	W4XBW	26,000	100W.
WDRC, Inc., Meriden, Conn.	W1XPW	40,400	1KW.
Westinghouse E. & M. Co., Boston, Mass.	W1XKA	42,220	50W.
Westinghouse E. & M. Co., East Springfield, Mass.	W1XKB	42,220 *42,380	50W. 1KW.
Westinghouse E. & M. Co., East Springfield, Mass.	W8XKA	42,220 *42,600	50W. 1KW.
WHB B'dc'st'g Co., Kansas City, Mo.	W9XBA	26,100	100W.
WKY Radiophone Co., Oklahoma City, Okla.	W5XAT	26,125	100W.
The Yankee Network, Inc., Sargents Purchase, N. H.	W1XER	42,340	500W.

Notes: Frequency Groups listed in Rule 1053:  
Group C: 35,600, 31,600, 38,600 and 41,000 kc.  
Group E (Selective) (1): 41,600, 86,500, 111,000 kc.; (2): 88,000, 120,000, 240,000 and 500,000 kc.

\*Construction permit only.  
\*\*Construction permit pending.  
Listings in italic are those of special frequency-modulated transmitters.  
C.B.S.—Columbia Broadcasting System, Inc.  
N.B.C.—National Broadcasting Company, Inc.

NEW CIRCUITS IN MODERN RADIO RECEIVERS

(Continued from preceding page)

proached by the signal it tends to draw energy away from the secondary so that a fairly uniform band-pass characteristic is obtained.

(5) BIAS OBTAINED FROM OSCILLATOR OUTPUT

Emerson Models DB-296 and DB-301. Rectified high-frequency current generated by the regular oscillator in these receivers supplies the normal bias for the 1st-detector and I.F. tubes.

Referring to Fig. 2C at point A there will

normally be an average negative voltage of approximately -18 volts when the oscillator is in operation. This is due to self-rectification of the grid. Impressed through the divider filter A, B, C, to ground, at B there will be approximately -3 volts; and at C, -0.25-volt, D.C. Before A.V.C. action occurs point B is the regular bias supply for the controlled tubes. The A.V.C. action is delayed until point C exceeds -3 volts or that of B due to rectification of a signal by the 12SQ7GT 2nd-detector. No matter how negative point B becomes due to the signal, it will hardly affect the voltage at A because of the relatively low value of the grid leak. Below -18 volts, B must change 750 volts for each volt change at A so the effect is negligible.

This circuit avoids wasteful cathode or power-supply voltage dropping resistors.

N.B.—There's an error in Fig. 2C. Arrow C should not point to ground but to junction of 3-meg. and 0.25-meg. resistors.—Ed.

BE A RADIO SERVICE EXPERT



Modern receivers require men with modern training for service work  
**LEARN AT HOME**  
Our home instruction method and service equipment offer starts you earning money almost at once. Up to \$8 an hour easy in a short time. Write for free book.  
Radio Training Ass'n of America  
DEPT. RC-129  
4325 Ravenswood Ave., Chicago

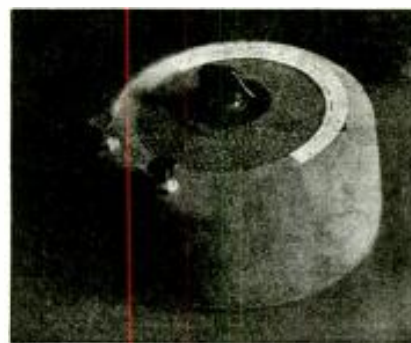

Model TBUR3  
Size 6½" diameter, 3" high

If it's a Talk-Bak\*  
It's Wright-DeCoster

With ALL the latest improvements Wright-DeCoster Talk-Bak\* units have become universally recognized as the finest equipment made for inter-communication systems.

Combining simplified installation, good appearance, excellent operation, and extremely long life (without service costs), Talk-Bak\* units fulfill practically every operating need in inter-communication work.

Write for Talk-Bak\* literature and catalog—include your distributor's name.  
Wright-DeCoster distributors are always anxious to cooperate.

WRIGHT-DECOSTER, Inc.

2251 University Ave., St. Paul, Minn.  
Export Dept.: M. Simons & Son Co., New York  
Cable Address: "Simonrice"  
Canadian Representatives:  
Wm. F. Kelly Co., 1207 Bay St., Toronto, Ontario  
Taylor & Pearson, Ltd., Edmonton, Alberta

\*Copyrighted.

Sensational •  
Mysterious •  
WIRELESS RECORD PLAYER

REPRODUCES PHONOGRAPH RECORDS THROUGH ANY RADIO without any connections between record player and radio set. No wires necessary.

By means of a newly developed unit using 2 tubes, energy from the "PICKUP" is transferred by radiation to your radio receiver within a distance of 25 feet or more, on the unused channel of your radio, and is tuned in like any other station. Will work with any SIZE RADIO REGARDLESS OF AGE, MAKE OR TYPE.

Requires absolutely no technical knowledge to install, just plug into your nearest electric socket. Permits normal operation of volume control and tone control of your radio. Instantly solves all impedance matching problems.

MICROPHONE OUTLET PERMITS YOU TO USE A CARBON MICROPHONE TO TRANSMIT YOUR VOICE THROUGH ANY RADIO.



FEATURES OF MODEL V-2

- \* OPERATION—110-120 volts 50 cycles
- \* PICKUP—Crystal tangent full floating arm—
- \* VOLUME CONTROL combined with on-off switch
- \* SELF STARTING MOTOR—78 R.P.M.
- \* PLAYS 10 OR 12 INCH RECORDS
- \* MICROPHONE OUTLET for carbon mike
- \* PORTABLE CASE — brown leatherette — sturdy and rugged
- \* Net weight—10 lbs.
- \* Shipping weight—14 lbs.
- \* Size 14½ x 11½ x 7 inches

\$9.95 READY TO USE WITH 2 TUBES

SPECIALS

- V3 in Walnut Cabinet Same Features as V2 ...\$12.95
- V4 Record Player in Walnut Cabinet ..... 9.95
- V5 Record Player in Portable Leatherette ..... 7.95
- Crystal Pickup ..... 2.95
- Self-Starting Motor Phono 10" Turntable ..... 2.95
- Two-Tube Wireless Phono Transmitter with Two Tubes ..... 3.95

FREE CATALOG ON REQUEST

DISCAPHONE MFG. CO., 396 Broadway, Room 902  
New York City

Please Say That You Saw It in RADIO-CRAFT

*It's NEW—and it's the one and only*  
**P. A. HANDBOOK**



**ONLY  
 25  
 CENTS  
 A COPY**

**MOST COMPLETE  
 AND AUTHENTIC  
 P.A. BOOK PUBLISHED**

THAT no book has yet been published which covers amplifiers and sound systems (also kindred systems), in one complete, authentic volume is almost unbelievable. Yet, it is a fact, there is no book in print which covers Public Address from A to Z. To bridge this wide-spread gap, RADIO-CRAFT will publish, on November 15th, a volume on Public Address of such magnitude—so complete and authoritative—that every man engaged in radio can have both a theoretical and practical knowledge of the function and operation of sound systems. The editorial pages are so filled with instruction and replete with illustrations that the volume fully justifies its title—1939-40 AMPLIFIER HANDBOOK AND PUBLIC ADDRESS GUIDE. This great HANDBOOK on Public Address should be read and studied by those who consistently build, service and sell sound equipment.

**A MATCHLESS VOLUME**

As complete as you would expect to find any engineering handbook—this is how the radio or P. A. man finds the **AMPLIFIER HANDBOOK AND PUBLIC ADDRESS GUIDE**. With essential technical data compiled from an exceptionally large number of sources, the volume covers nearly two hundred different subjects, coordinating every conceivable branch or sub-division of Public Address.

**THE CONTENTS**

To actually show the scope and magnitude of the **AMPLIFIER HANDBOOK AND PUBLIC ADDRESS GUIDE**, an analysis of the contents is found at the right, showing the breakdown of the material featured within each particular section. A thorough reading of the contents shows the completeness of this book.

**RADCRAFT PUBLICATIONS • 99 HUDSON STREET • NEW YORK, N. Y.**

RADCRAFT PUBLICATIONS, INC. • 99 HUDSON STREET • NEW YORK, N. Y. RC-1239  
 Gentlemen: Enclosed find my remittance of 25¢ for which send me POSTPAID, one copy of your NEW—1939-40 AMPLIFIER HANDBOOK AND PUBLIC ADDRESS GUIDE.

Send me ..... others, for friends, also POSTPAID @ 25¢ each.

Name ..... Address .....

City ..... State .....

Remit by check or money order; register letter if you send cash or unused U.S. Postage stamps.

**A Resume of the Contents of the  
 AMPLIFIER HANDBOOK  
 AND PUBLIC ADDRESS GUIDE**

**PREFACE**

**INTRODUCTION**

**CHAPTER I—FUNDAMENTALS**

Vacuum Tube as Amplifier—Ratings—Belts and Decibels—Harmonics—Distortion—Attenuation—Gain—Ohm's Law—Bridge Circuits—Rectification—Microphones—Condensers—Resistors—Impedance—Phase—Resonance—Inductance—Frequency—Magnetism—Shielding.

**CHAPTER II—VACUUM TUBES**

Voltage Amplifiers—Power Amplifiers—Control and Indicator Tubes—Rectifiers—Ballast and Regulator.

**CHAPTER III—CIRCUIT ANALYSIS**

Inputs—Coupling—Degeneration (Inverse Feedback)—Frequency Compensation—Outputs—Push-Pull—Phase Inversion—Class A, A-B, B, A', etc.—Hum-Bucking—Automatic Gain Control—Spectrum Control—Time-Delay—Tone Compensation—Voltage Dividers—Swinging Chokes—Beam Power—Push-Pull.

**CHAPTER IV—MICROPHONES**

Carbon—Condenser—Electrodynamic—Ribbon (Velocity)—Crystal—Lapel—Uni-directional (cardioid)—Electromagnetic—Transducers.

**CHAPTER V—AMPLIFIERS AND PREAMPLIFIERS**

A.C.—D.C.—A.C.—D.C. (120 V.)—A.C.—D.C. (6 V. D.C. • 120 V. A.C.)—Mobile—Portable—Multi-Channel—Biphonic—Preamplifiers—Monitors.

**CHAPTER VI—LOUDSPEAKERS**

Magnetic—Dynamic—P.M. Dynamic—Crystal—Horn Units.

**CHAPTER VII—HORNS AND BAFFLES**

Flat—Infinite—Octave Resonance—Exponential—Flares—Labyrinths—Peridynamic—Biphonic.

**CHAPTER VIII—AMPLIFIER COMPONENTS**

Resistors—Condensers—Transformers—Chokes—Fuses—Sockets—Chassis and Housings—Meters—Name Plates and Bezels—Terminals—Jacks and Plugs—Switches—Frequency Filters—Bias Cells—Tone and Volume (Attenuator) Controls—Pads—L. T. H., etc.

**CHAPTER IX—POWER SUPPLIES**

Power Lines—Batteries—Converters and Generators—Rectifier Tubes—Dry Rectifiers—Vibrators and Inverters—Bias Supplies—Field Exciters—Ballasts and Regulators.

**CHAPTER X—ACCESSORIES**

Coin Phonographs—P.A. Tuners.

**CHAPTER XI—RECORDING AND PLAYBACK**

Pickups—33-1/3 and 78 r.p.m. Turntables—Film, Disc and Wire—Recorders—Lateral and Vertical (hill-and-dale) Recording—High Fidelity Recording and Playback—Accessories.

**CHAPTER XII—MATCHING AND MIXING**

Input to Amplifier—Amplifier to Line—Line to Speakers—Pads—Attenuators—Matching Amplifiers—Booster Amplifiers.

**CHAPTER XIII—ACOUSTICS**

Absorption—Reverberation and Echo—Low-Level Distribution—High-Level Distribution.

**CHAPTER XIV—SELLING SOUND**

Ethics—Who are the prospects?—What are reasonable charges?—Sidelines—Accounting—Advertising and Publicity.

**CHAPTER XV—SCHOOL SOUND SYSTEMS**

**CHAPTER XVI—CALL SYSTEMS**

Railroads—Hotels—Restaurants.

**CHAPTER XVII—INTERCOMMUNICATORS**

Wire Type—Wired—Radio Type—Switchless—Multiple-Station.

**CHAPTER XVIII—TALKIES**

Soundheads—Amplifiers—Loudspeakers—Sound-on-Film—Sound-on-Disc—Home-Talkies—Commercial-Talkies.

**CHAPTER XIX—HEARING AIDS**

Tubeless—Tube Type.

**CHAPTER XX—MISCELLANEOUS APPLICATIONS**

**CHAPTER XXI—FORMULAS AND TABLES**

**CHAPTER XXII—TEST EQUIPMENT**

Multi-Meters—C.R. Oscilloscope—A.F. Oscillators—Output (Level) Indicators—V.T. Voltmeters.

**CHAPTER XXIII—INSTALLATION PROCEDURE**

Placement of Equipment (Microphones, Amplifiers, Loudspeakers)—Use of Woofers and Tweeters—Wiring—Indoors and Outdoors—Portable and Mobile Set Ups—Permanent Installations.

**CHAPTER XXIV—SERVICING**

**Order Your Copy NOW—**

*Clip Coupon and  
 Mail Today!*

Please Say That You Saw It in RADIO-CRAFT



## WAR NEWS VIA RADIO

(Continued from page 375)

terns. In the middle of the battery-like box is a dial calibrated in *minutes*, a center knob marked in *seconds*, and a red hand which starts moving the moment the device is set into operation. When the red hand stops at zero (placed where the "12" is on the ordinary clock face) it indicates that all the allotted time has been consumed. At this, 2 photo-flood bulbs set in the 2 red lanterns flash—so swiftly and brightly that even if the announcer's back is turned, he cannot miss the signal. (See photo, pg. 327.)

To eliminate the necessity for opening and closing the door of Studio 9 when special bulletins of importance come in during air-time, a unique "news-slit" has been constructed in the studio wall through which bulletins can be slipped to the announcer inside.

Paul White's office and the adjoining news ticker and cable rooms are all designed so that, in an emergency, they can be placed instantly in contact with every department of C.B.S. Mr. White's telephone, for example, is no ordinary telephone, but the focal point for desk telephones all over the building. When he picks it up to make an emergency call, the telephones of executives in at least a dozen departments ring instantly, and a red light flashes on at their respective desks. This simple factor is of the utmost importance during a crisis, when at a moment's notice, Mr. White must clear network time, arrange for the rerouting of programs, and accomplish a half-dozen other details connected with a sudden change in schedule.

### WORLD-WIDE "LISTENING ROOM"

Probably the most interesting room during the present war is the "listening room" adjoining Studio 9. Here shortwave broadcasts are received from 24 foreign countries

for translation by a group of linguists.

These broadcasts are never heard on the C.B.S. network, but they are important to Columbia's war coverage as background material, inasmuch as they often contain news bulletins and official statements issued by foreign governments, which are indicative of news trends. Of course a good many also contain propaganda, atrocity stories, and the like, but it is up to the broadcasters to check on such information and make sure that it is reliable before using it.

### DX RECEIVING STATION

Columbia maintains its own receiving station for these shortwave programs. It is a 10 x 12 foot shack out at Forest Hills, in a spot which was selected after long search by the C.B.S. engineers, as being satisfactory for clear reception from abroad.

Equipment inside consists of commercial receivers, modified by the engineering department for extreme sensitivity. They are capable of tuning-in on shortwave programs not only directed to the United States from Europe, but on European shortwave broadcasts which have been beamed to such remote places as South Africa, China, and India.

News, as one can see from the foregoing descriptions, is coming in to C.B.S. from many sources. Technically, the set-up for getting it speedily on the air is practically perfect. The only problems still left to the broadcasters are those of accuracy, foreign censorship, and neutrality. And these are matters outside the realm of traffic and engineering operations.

*Radio-Craft* extends its thanks to C.B.S.'s Miss Lucille Fletcher for her cooperation in making this article and its illustrations available.

## WIDE-RANGE LOUDSPEAKER

(Continued from page 339)

out to a limit of 12,000 to 15,000 cycles by means of the new reproducer design.

In other words the electrical signal to the voice coil may be "flat" (without any serious drop) out to about 18,000 cycles but this limit is not reached in the acoustical reproduction. In general the effective frequency response range of the new loudspeaker design described here may be taken as about 12,000 to 13,000 cycles.

The practical limit of the high-frequency response of this loudspeaker, as with any reproducer, is partly a function of the signal intensity at these high frequencies. In other words if means are provided for making the limits of the high-frequency range disproportionately strong these frequencies may be reproduced where otherwise they would not be heard. The essential difference between this "Single-Unit Wide-Range Loudspeaker" (now standard equipment in one G.E. frequency-modulated receiver) and preceding types is that, in addition to the response being more uniform throughout the entire audio range, the response limit is reached at a new high frequency.—*Editor*

RADIO-CRAFT  
Gentlemen:

We wish to call to your attention, a statement in the June issue of *Radio-Craft*, and which we think is entitled to some discussion. This appears in the article headed

"The Radio Month in Review" and is the first paragraph on page 748 which reads as follows:

"Another outstanding achievement brought to light at this meeting was the G.E. high-fidelity loudspeaker now standard in the new 'F.M.' receivers of the same make. A smoothly-graded range in the thickness of the loudspeaker diaphragm serves to maintain uniform compliance right out to the carpinchoe edge of the cone. The result is a unit readily capable of handling over 9 W. with a frequency range plus or minus 1 db., of 30 to 18,000 cycles."

We wish to challenge these facts and render very serious objections to the printing of such statements in your magazine. This speaker in question comes nowhere near this performance and we feel that such exaggerated statements in connection with speaker characteristics do serious damage in the industry by establishing false impressions in the minds of the public and misleading them in their demands in connection with speaker results. We doubt very much if the speaker in question has a response covering half the frequency range mentioned, with less than a 10 db. total variation from uniform response.

The principle involved in this case is a very serious one and we feel that more attention is going to have to be paid to

(Continued on following page)

Please Say That You Saw It in RADIO-CRAFT

Save Money!  
With the

## RADOLEK RADIO PROFIT GUIDE!

164  
PAGES

EVERYTHING IN RADIO  
AT LOWEST PRICES!

Radolek offers you the MOST in your money! Lowest Prices! Best Quality! Biggest Values! Most Complete Stock! Fastest Service! Send for your FREE copy NOW!

### OVER 15,000 REPAIR PARTS

The world's most complete stock of radio repair parts and exact duplicate replacements. All leading brands. All guaranteed. Lowest Prices!

### COMPLETE TUBE SELECTION

All types, RCA, Sylvania, Raytheon, Philco, etc. Includes Kellogg, special Majestic types and transmitting tubes. Complete selection.

### NEWEST TEST INSTRUMENTS

The most complete line ever displayed in any catalog. All leading makes. Latest improved models at lowest prices.

### GREATEST RADIO VALUES

A huge selection of money-saving sets, bargains! New Phono-Radio combinations. Automatic tuning sets. Beautiful cabinets. New "Ham" receivers and equipment.

### EVERYTHING FOR AUTO RADIO

Complete auto radio section. Includes vibrator replacement guide, new auto aerales, custom panel control plates for all autos, newest Auto Sets.

### COMPLETE P. A. SELECTION

New 1940 public address amplifiers from 5 to 100 watts. Complete P. A. Systems for permanent, mobile and portable installations. Best values!

### NEW ELECTRICAL APPLIANCES

Extra profits for you! Standard Brand Electric Irons, Stoves, Heaters, Perculators, Waffle Irons, Vacuum Cleaners, Trains, Clocks, Mixers, etc., at lowest prices!

FREE!  
Mail Coupon Catalog!

The RADOLEK Co.

601 W. Randolph, Chicago,

Dept. C-36

Send the 1940 Radolek Radio Profit Guide FREE.

Name .....

Address .....

Service man?  Dealer?  Experimenter?



# WHAT IS AN "EXPENSIVE" RESISTOR?

You can buy resistors at almost any price—but remember, you generally get just about what you pay for. One lost service customer, one call-back as the result of trouble with a "cheap" resistor can cost far more than you can possibly save on dozens of resistor "bargains."

Insist on IRC Insulated Metallized Resistors—the finest most reliable resistors at any price. You can rely on them any time, any place, under the most severe conditions. They are a good investment in long, satisfactory performance. They are the least expensive resistors to use because they are the best resistors for protecting your reputation for highest quality workmanship on every job.

## INTERNATIONAL RESISTANCE CO.

401 N. Broad St., Philadelphia, Pa.



- 1/2-WATT (BT-1/2) 17¢ List
- 1-WATT (BT-1) 20¢ List
- 2-WATTS (BT-2) 30¢ List



**INSULATED Metallized RESISTORS**

*"They Stay Put"*

(Continued from preceding page)

statements of facts concerning characteristics of radio equipment, because these exaggerations are gradually increasing due to the fact that each one follows, in a comparative sense, with a more exaggerated statement from the balance of the field, which is cumulative in effect and which, having reached its present extreme is rapidly destroying the public's confidence in the honesty of the industry.

We are becoming increasingly alarmed about this condition and feel that an organized movement must soon be made to correct these practices.

With the hope that this letter may at least direct a trend of thought with this objective in mind, we are

L. B. BRITAIN,  
Lansing Manufacturing Co.

### STATEMENT OF THE OWNERSHIP, MANAGEMENT, CIRCULATION, ETC., REQUIRED BY THE ACTS OF CONGRESS OF AUGUST 24, 1912, AND MARCH, 3 1933.

Of RADIO-CRAFT, published monthly at Springfield, Mass., for October 1, 1939.

State of New York } ss.  
County of New York }

Before me, a Notary Public in and for the State and county aforesaid, personally appeared H. Gernsback, who, having been duly sworn according to law, deposes and says that he is the editor of *Radio-Craft* and that the following is, to the best of his knowledge and belief, a true statement of the ownership, management (and if a daily paper, the circulation), etc., of the aforesaid publication for the date shown in the above caption, required by the Act of August 24, 1912 and as amended by the Act of March 3, 1933, embodied in section 537, Postal Laws and Regulations, printed on the reverse of this form, to wit:

1. That the names and addresses of the publisher, editor, managing editor, and business managers are: Publisher, Radcraft Publications, Inc., 99 Hudson St., New York, N. Y.; Editor, H. Gernsback, 99 Hudson St., New York, N. Y.; Managing Editor, R. D. Washburne, 99 Hudson St., New York, N. Y.; Business Managers, none.
2. That the owner is: (if owned by a corporation, its name and address must be stated and also immediately thereunder the names and addresses of stockholders owning or holding one per cent or more of total amount of stock. If not owned by a corporation, the names and addresses of the individual owners must be given. If owned by a firm, company, or other unincorporated concern, its name and address, as well as those of each individual member, must be given.) Radcraft Publications, Inc., 99 Hudson St., New York, N. Y.; H. Gernsback, 99 Hudson St., New York, N. Y.
3. That the known bondholders, mortgagees, and other security holders owning or holding 1 per cent or more of total amount of bonds, mortgages, or other securities are: (if there are none, so state.) None.
4. That the two paragraphs next above, giving the names of the owners, stockholders, and security holders, if any, contain not only the list of stockholders and security holders as they appear upon the books of the company but also, in cases where the stockholder or security holder appears upon the books of the company as trustee or in any other fiduciary relation, the name of the person or corporation for whom such trustee is acting, is given; also that the said two paragraphs contain statements embracing affiant's full knowledge and belief as to the circumstances and conditions under which stockholders and security holders who do not appear upon the books of the company as trustees, hold stock and securities in a capacity other than that of a bona fide owner; and this affiant has no reason to believe that any other person, association, or corporation has any interest direct or indirect in the said stock, bonds, or other securities than as so stated by him.
5. That the average number of copies of each issue of this publication sold or distributed, through the mails or otherwise, to paid subscribers during the twelve months preceding the date shown above is.....  
(This information is required from daily publications only.)

H. GERNSBACK, Publisher.  
Sworn to and subscribed before me this 20th day of Sept., 1939.

MAURICE COYNE, Notary Public.  
Notary Public, N. Y. Co. No. 562  
(My commission expires March 30, 1940.)

## Index to advertisers

<b>A</b>	
Allied Radio Corporation.....	361
Amperite Corporation.....	363
Amplifier Co. of America.....	366
Amplitone Products Company.....	359
Arrow Sales Company.....	372
<b>B</b>	
Burstein-Applebee Company.....	365
<b>C</b>	
Capitol Radio Engineering Inst.....	375
Classified Section.....	374
Cornell-Dubilier Elec. Corp. Inside Front Cover	
Coyne Electrical School.....	323
<b>D</b>	
The Data Print Company.....	377
Discaphone Manufacturing Co.....	381
<b>G</b>	
Gold Shield Products Co.....	371
Goldentone Radio Company.....	366
<b>H</b>	
Hammarlund Manufacturing Co.....	365
Hudson Specialties Company.....	380
Hygrade Sylvania Corporation.....	373
<b>I</b>	
International Resistance Co.....	381
<b>L</b>	
Lancaster, Allwine & Rommel.....	375
Lincoln Engineering School.....	372
<b>M</b>	
Meissner Manufacturing Co.....	379
Midwest Radio Corporation.....	372
Arthur G. Mohaupt.....	367
<b>N</b>	
National Radio Parts Distributors Assn.....	375
National Plans Institute.....	368
National Radio Institute.....	321
National Schools.....	366
National Union Radio Corp.....	360
New York Radio Supply Company.....	368
New York YMCA Schools.....	366
<b>O</b>	
Olson Manufacturing Company.....	363
<b>R</b>	
Radio & Tech. Publishing Co.....	377
Radio City Products Company.....	371
Radio Servicemen of America.....	370
Radio Training Association.....	381
Radio Wire Television, Inc.....	353
Radolek Company.....	383
RCA Institutes, Inc.....	369
RCA Manufacturing Co., Inc.....	Back Cover
Readrite Meter Works.....	363
Remington Rand, Inc.....	368
<b>S</b>	
E. H. Scott Radio Labs.....	369
Sears, Roebuck & Co.....	369
Solar Manufacturing Co.....	361
Sprayberry Academy of Radio.....	362
Superior Instruments Co.....	356
Supreme Instruments Corp.....	367
Supreme Publications.....	373
<b>T</b>	
Technifax.....	366
Triplett Elec. Instrument Co.....	364
The Turner Company.....	364
<b>U</b>	
Universal Microphone Co., Ltd.....	359
<b>W</b>	
Montgomery Ward & Co.....	375
Wellworth Trading Company.....	368, 372
Weston Elec. Instrument Corp.....	Inside Back Cover
Wright-DeCoster, Inc.....	341

(While every precaution is taken to insure accuracy, we cannot guarantee against the possibility of an occasional change or omission in the preparation of this index.)



Here's a brand new  
feature that will **UP**  
your profits!

A Battery  
Condition Test  
"Good - Replace"



Available in  
counter and  
portable types

## THE NEW WESTON

MODEL 777

### TUBE and BATTERY TESTER

tests batteries as well as tubes under load  
... gives dealers and servicemen extra  
sales and profit from battery replacements!

Look at the figures ... and the opportunity. Over 30% of radio sales in recent months were portable battery or combination receivers. And sales still mounting and expected to climb in 1940. Here's a real opportunity to sell tubes ... and a *brand new market in the sale of battery replacements.* » » » To enable servicemen and dealers to "cash in" on this opportunity, WESTON provides the Model 777 Tester ... which not only provides a thorough check on all tubes, but also tests *all* radio batteries under load. The "Good - Replace" scale instantly indicates whether the battery delivers sufficient potential to insure good reception. (Such a test cannot be made with ordinary battery testers, nor with high current drain meters.) » » » So with Model 777 you not only will be equipped with a tube checker that will remain serviceable for years, but you also will be able to check the batteries while you are checking the tubes. No tube checker today is up-to-date unless it supplies this battery test ... enables you to give complete customer satisfaction, with *more profit for yourself.* Be sure you have complete information on Model 777. Return the coupon today.

#### Tests Radio Batteries Under Correct Load

"Good - Replace" indications based on battery manufacturers' standards and receiver requirements for good reception.

- ★ Tests high filament voltage tubes (up to 117 volt types)
- ★ Tests Loktal tubes
- ★ Tests OZ4
- ★ Tests ballast tubes
- ★ Tests for shorts
- ★ Tests for noise
- ★ Tests open elements
- ★ Individual element test
- ★ Spare socket for possible future requirement
- ★ Large WESTON Meter

WESTON ELECTRICAL INSTRUMENT CORP.

599 Frelinghuysen Avenue  
Newark, New Jersey

Send literature on the Model 777 Tube and Battery Tester.

Name \_\_\_\_\_

Address \_\_\_\_\_

City \_\_\_\_\_ State \_\_\_\_\_

# From zero to 44 million in 20 years!

in two decades research in RCA Laboratories has played a big part in making radio set ownership exceed the figures for any other electrical device

People want radio sets more than they want anything else in the line of electrical equipment. This is proved by the fact that there are in the United States more radio sets than electric irons, or toasters, or washing machines, or vacuum cleaners, or any other electrical device. Even the 44 million radios in this country are not enough. Millions of homes want *more* radios, and want to replace old models with new.

RCA takes pride in the fact that the intense public interest in radio, and the ever-growing market for radio sets, both rest in no small degree on research in RCA Laboratories. From these studies there have come many of the important advances constantly made in set design and performance.

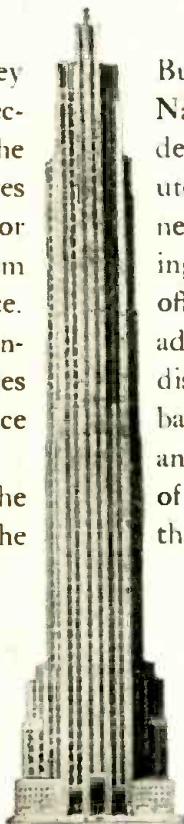

But RCA does more. Through the National Broadcasting Company it renders a fundamental service that contributes to the life-blood of the radio business... broadcasting. For interest in buying radio sets depends on a continuous offering of good programs, and constant advance in the art of broadcasting. NBC discovered or developed many of the basic principles of radio entertainment, and is responsible for a large proportion of the advances that have been made in the technical aspects of broadcasting.

This year RCA celebrates its twentieth anniversary, confident that it has rendered in two decades a pioneering service of the utmost importance to a great American industry as well as to the American public.



## RADIO CORPORATION OF AMERICA

RADIO CITY, N. Y.

RCA Manufacturing Co., Inc.  
R.C.A. Communications, Inc.

RCA Laboratories  
National Broadcasting Company

Radiomarine Corporation of America  
RCA Institutes, Inc.